

RoHS Compliant

CFast 2.0

Industrial SM220-CFast Product Specifications



January 12, 2024

Version 1.0



Apacer Technology Inc.

1F, No.32, Zhongcheng Rd., Tucheng Dist., New Taipei City, Taiwan, R.O.C

Tel: +886-2-2267-8000 Fax: +886-2-2267-2261

www.apacer.com

Specifications Overview:

- **Standard Serial ATA Interface**
 - SATA Revision 3.1 compliance
 - SATA 6 Gb/s interface speed
 - Backward compatible with SATA 1.5/3 Gb/s interfaces
 - ATA-compatible command set
- **Capacity**
 - 8, 16, 32, 64, 128, 256 GB
- **Performance¹**
 - Sequential read: Up to 550 MB/sec
 - Sequential write: Up to 355 MB/sec
 - Random read (4K): Up to 76,000 IOPS
 - Random write (4K): Up to 43,000 IOPS
- **Flash Management**
 - Built-in hardware ECC
 - Global Wear Leveling
 - Flash bad-block management
 - Flash Translation Layer: Page Mapping
 - S.M.A.R.T.
 - Power Failure Management
 - Device Sleep (optional)
 - ATA Secure Erase
 - TRIM
- **NAND Flash Type: MLC**
- **MTBF: >1,000,000 hours**
- **Endurance (in Terabytes Written: TBW)**
 - 8 GB: 13 TBW
 - 16 GB: 29 TBW
 - 32 GB: 66 TBW
 - 64 GB: 136 TBW
 - 128 GB: 297 TBW
 - 256 GB: 309 TBW
- **Temperature Range**
 - Operating:
 - Standard: 0°C to 70°C
 - Wide: -40°C to 85°C
 - Storage: -55°C to 100°C
- **Power Consumption¹**
 - Supply voltage: 3.3V
 - Active mode: 705 mA
 - Idle mode: 85 mA
- **Connector Type**
 - 7 + 17 pin female connector
- **Physical Characteristics**
 - Form factor: CFast
 - Dimensions: 42.80 x 36.45 x 3.60_(max.), unit: mm
- **Write Protect Switch (optional)**
- **RoHS Compliant**

Note:

1. Varies from capacities. The values for performances and power consumptions presented are typical and may vary depending on flash configurations or platform settings. The term idle refers to the standby state of the device.

Table of Contents

1. General Description	4
2. Functional Block	4
3. Pin Assignments.....	5
4. Product Specifications.....	7
4.1 Capacity.....	7
4.2 Performance	7
4.3 Environmental Specifications	8
4.4 Mean Time Between Failures (MTBF)	8
4.5 Certification and Compliance.....	8
4.6 Endurance	9
5. Flash Management	10
5.1 Error Correction/Detection.....	10
5.2 Bad Block Management	10
5.3 Global Wear Leveling	10
5.4 Flash Translation Layer – Page Mapping.....	10
5.5 ATA Secure Erase.....	10
5.6 Power Failure Management	11
5.7 TRIM.....	11
5.8 Device Sleep (DevSleep or DEVSLP) Mode (optional).....	11
5.9 SATA Power Management.....	12
6. Software Interface	13
6.1 Command Set.....	13
6.2 S.M.A.R.T.	14
7. Electrical Specifications.....	15
7.1 Operating Voltage.....	15
7.2 Power Consumption	15
8. Mechanical Specifications.....	16
8.1 Physical Dimensions	16
8.2 Write Protect Switch (optional)	17

9. Product Ordering Information.....	18
9.1 Product Code Designations.....	18
9.2 Valid Combinations.....	19

1. General Description

Apacer SM220-CFast is the latest enhancement of conventional CFast form factor that delivers various technological advantages. This new flash memory card comes with SATA 6 Gb/s interface for exceptional performance and consists of SATA-based 7-pin signal segment and 17-pin for power and control purposes. For data efficiency, the internal controlling unit of the SM220-CFast is engineered with DRAM for enhanced random performance which achieves data transfer rates up to 550 MB/s in sequential access and 76,000 IOPS in 4KB random access.

SM220-CFast guarantees reliability of applications in harsh environments by implementing intelligent Flash Management algorithms and error correction. Operating under 6 Gb/s interface, SM220-CFast is provided with Apacer latest S.M.A.R.T. for drive lifetime monitoring and analysis.

In terms of security, Write Protect is available to prevent drives from unauthorized data writing via a hardware switch/pin or vendor software command, if required. SM220-CFast also adopts the latest page mapping file translation layer and comes with various implementations including flash block management, power failure management, TRIM, and power saving modes.

With exceptional performance, trustable reliability, and enhanced data protection, SM220-CFast is definitely the ideal storage or cache solution for a variety of applications ranging from industrial, imaging, computing to enterprise markets.

2. Functional Block

Apacer SM220-CFast includes a single-chip controller designed with a DRAM and flash media. The controller integrates the flash management unit to support multi-channel, multi-bank flash arrays. Figure 2-1 shows the functional block diagram.

Note: The actual number of NAND flash used on Apacer SM220-CFast varies from capacities. The illustration is for reference only.

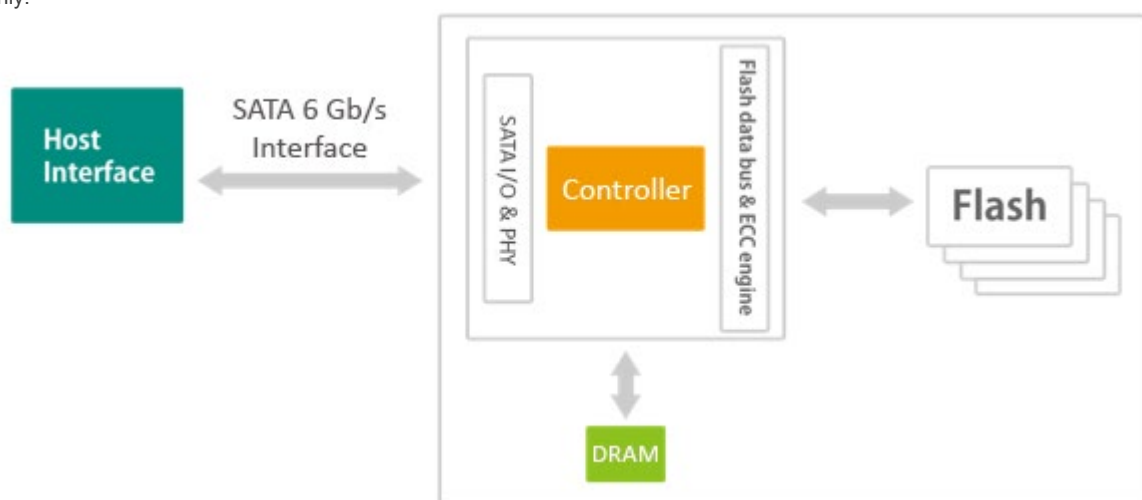

Figure 2-1 Functional Block Diagram

3. Pin Assignments

Table 3-1 describes SM220-CFast signal segment, and Table 3-2, its power segment.

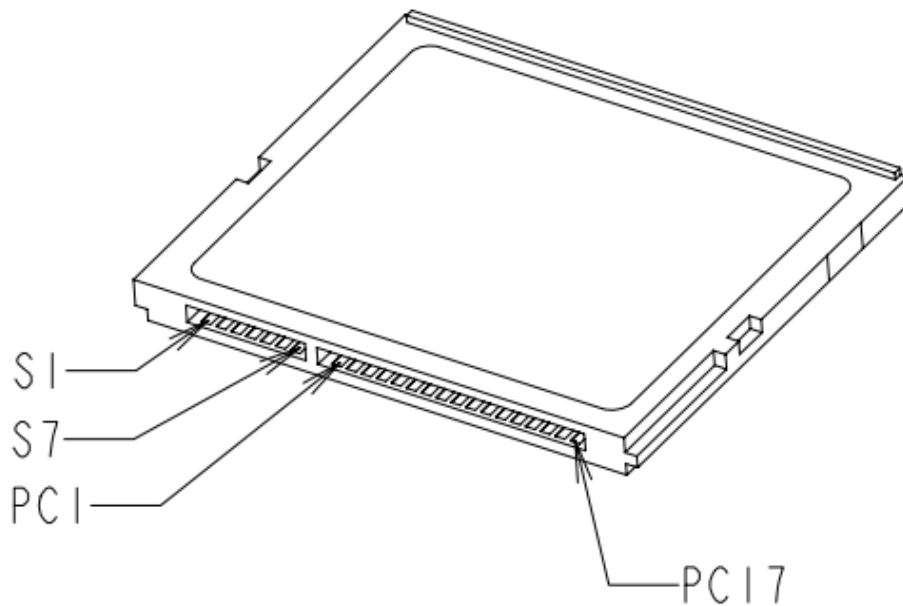

Figure 3-1 Pin Assignment

Table 3-1 Signal Segment

Pin	Definition	Description
S1	GND	Ground
S2	A+	SATA Differential Signal Pair A
S3	A-	
S4	GND	Ground
S5	B-	SATA Differential Signal Pair B
S6	B+	
S7	GND	Ground

Table 3-2 Power Segment

Pin	Definition	Type	Description
PC1	CDI	Input	Card Detect In
PC2	PGND	Device GND	Device GND
PC3	DEVSLP ¹	DEVSLP card input	DEVSLP enable
PC4			Reserved
PC5			Reserved
PC6			Reserved
PC7	PGND	Device GND	Device GND
PC8	LED1	LED Output	Power indicator
PC9	LED2	LED Output	Access indicator
PC10			Reserved
PC11			Write Protect ²
PC12	IFDet	GND	Card output, connect to PGND on card
PC13	PWR	3.3V	Device power (3.3V)
PC14	PWR	3.3V	Device power (3.3V)
PC15	PGND	Device GND	Device GND
PC16	PGND	Device GND	Device GND
PC17	CDO	Output	Card Detect Out

Notes:

1. Optional.
2. Enabled by adjusting the pin "PC11" from high to low active

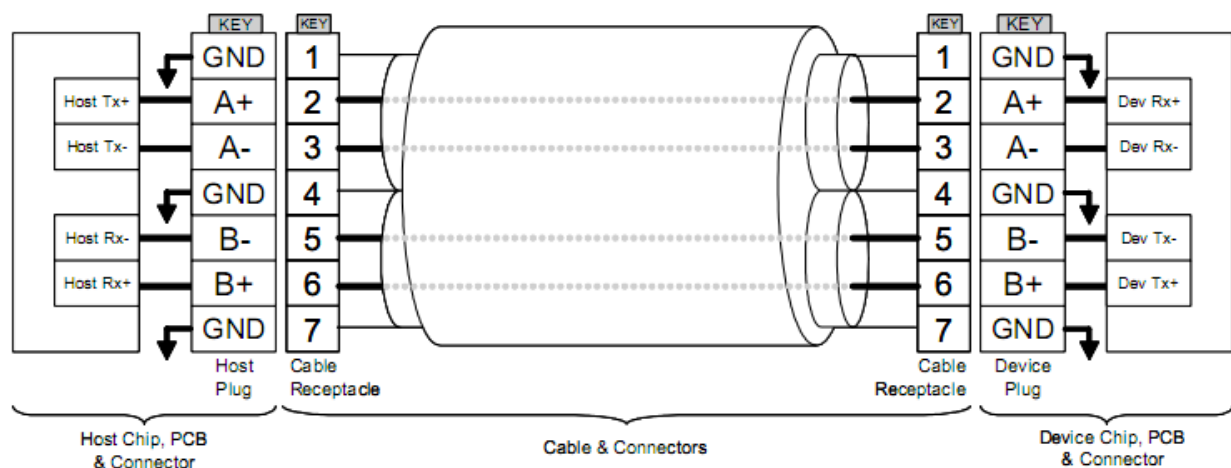

Figure 3-2 SATA Cable / Connector Connection Diagram

The connector on the left represents the Host with TX/RX differential pairs connected to a cable while the connector on the right shows the Device with TX/RX differential pairs also connected to the cable. Notice also the ground path connecting the shielding of the cable to the Cable Receptacle.

4. Product Specifications

4.1 Capacity

Capacity specifications of SM220-CFast are available as shown in Table 4-1. It lists the specific capacity and the default numbers of heads, sectors and cylinders for each product line.

Table 4-1 Capacity Specifications

Capacity	Total bytes	Cylinders	Heads	Sectors	Total LBA
8 GB	8,012,390,400	15,525	16	63	15,649,200
16 GB	16,013,942,784	16,383	16	63	31,277,232
32 GB	32,017,047,552	16,383	16	63	62,533,296
64 GB	64,023,257,088	16,383	16	63	125,045,424
128 GB	128,035,676,160	16,383	16	63	250,069,680
256 GB	256,060,514,304	16,383	16	63	500,118,192

Notes:

- Display of total bytes varies from operating systems.
- 1 GB = 1,000,000,000 bytes; 1 sector = 512 bytes.
- LBA count addressed in the table above indicates total user storage capacity and will remain the same throughout the lifespan of the device. However, the total usable capacity of the SSD is most likely to be less than the total physical capacity because a small portion of the capacity is reserved for device maintenance usages.

4.2 Performance

Performance of SM220-CFast is listed below in Table 4-2.

Table 4-2 Performance Specifications

Capacity	8 GB	16 GB	32 GB	64 GB	128 GB	256 GB
Performance						
Sequential Read (MB/s)	120	220	395	435	535	550
Sequential Write (MB/s)	26	50	100	90	180	355
4K Random Read (IOPS)	15,000	26,000	48,000	45,000	76,000	55,000
4K Random Write (IOPS)	3,000	10,000	24,000	22,000	43,000	28,000

Notes:

- Results may differ from various flash configurations or host system setting.
- Sequential read/write is based on CrystalDiskMark 5.2.1 with file size 1,000MB.
- Random read/write is measured using IOMeter with Queue Depth 32.
- 256GB adopts 8K mapping algorithm.

4.3 Environmental Specifications

Environmental specifications of SM220-CFast product are shown in Table 4-3.

Table 4-3 Environmental Specifications

Parameter	Type	Specifications
Temperature	Operating	0°C to 70°C (Standard); -40°C to 85°C (Wide)
	Non-operating	-55°C to 100°C
Vibration	Operating	7.69 GRMS, 20~2000 Hz/random (compliant with MIL-STD-810G)
	Non-operating	4.02 GRMS, 15~2000 Hz/random (compliant with MIL-STD-810G)
Shock	Operating	Acceleration, 50(G)/11(ms)/half sine (compliant with MIL-STD-202G)
	Non-operating	Acceleration, 1500(G)/0.5(ms)/half sine (compliant with MIL-STD-883K)

Note: This Environmental Specification table indicates the conditions for testing the device. Real world usages may affect the results.

4.4 Mean Time Between Failures (MTBF)

Mean Time Between Failures (MTBF) is predicted based on reliability data for the individual components in SM220-CFast. The prediction result for SM220-CFast is more than 1,000,000 hours.

Note: The MTBF is predicated and calculated based on “Telcordia Technologies Special Report, SR-332, Issue 3” method.

4.5 Certification and Compliance

SM220-CFast complies with the following standards:

- CE
- UKCA
- FCC
- RoHS
- MIL-STD-810G

4.6 Endurance

The endurance of a storage device is predicted by TeraBytes Written based on several factors related to usage, such as the amount of data written into the drive, block management conditions, and daily workload for the drive. Thus, key factors, such as Write Amplifications and the number of P/E cycles, can influence the lifespan of the drive.

Table 4-4 Endurance Specifications

Capacity	TeraBytes Written
8 GB	13
16 GB	29
32 GB	66
64 GB	136
128 GB	297
256 GB	309

Notes:

- The measurement assumes the data written to the SSD for test is under a typical and constant rate.
- The measurement follows the standard metric: 1 TB (Terabyte) = 1,024 GB.
- This estimation complies with JEDEC JESD-219, enterprise endurance workload of random data with payload size distribution.

5. Flash Management

5.1 Error Correction/Detection

SM220-CFast implements a hardware ECC scheme, based on the BCH algorithm. It can detect and correct up to 72 bits error in 1K bytes.

5.2 Bad Block Management

Current production technology is unable to guarantee total reliability of NAND flash memory array. When a flash memory device leaves factory, it comes with a minimal number of initial bad blocks during production or out-of-factory as there is no currently known technology that produce flash chips free of bad blocks. In addition, bad blocks may develop during program/erase cycles. Since bad blocks are inevitable, the solution is to keep them in control. Apacer flash devices are programmed with ECC, page mapping technique and S.M.A.R.T to reduce invalidity or error. Once bad blocks are detected, data in those blocks will be transferred to free blocks and error will be corrected by designated algorithms.

5.3 Global Wear Leveling

Flash memory devices differ from Hard Disk Drives (HDDs) in terms of how blocks are utilized. For HDDs, when a change is made to stored data, like erase or update, the controller mechanism on HDDs will perform overwrites on blocks. Unlike HDDs, flash blocks cannot be overwritten and each P/E cycle wears down the lifespan of blocks gradually. Repeatedly program/erase cycles performed on the same memory cells will eventually cause some blocks to age faster than others. This would bring flash storages to their end of service term sooner. Global wear leveling is an important mechanism that levels out the wearing of all blocks so that the wearing-down of all blocks can be almost evenly distributed. This will increase the lifespan of SSDs.

5.4 Flash Translation Layer – Page Mapping

Page mapping is an advanced flash management technology whose essence lies in the ability to gather data, distribute the data into flash pages automatically, and then schedule the data to be evenly written. Page-level mapping uses one page as the unit of mapping. The most important characteristic is that each logical page can be mapped to any physical page on the flash memory device. This mapping algorithm allows different sizes of data to be written to a block as if the data is written to a data pool and it does not need to take extra operations to process a write command. Thus, page mapping is adopted to increase random access speed and improve SSD lifespan, reduce block erase frequency, and achieve optimized performance and lifespan.

5.5 ATA Secure Erase

ATA Secure Erase is an ATA disk purging command currently embedded in most of the storage drives. Defined in ATA specifications, (ATA) Secure Erase is part of Security Feature Set that allows storage drives to erase all user data areas. The erase process usually runs on the firmware level as most of the ATA-based storage media currently in the market are built-in with this command. ATA Secure Erase can securely wipe out the user data in the drive and protects it from malicious attack.

5.6 Power Failure Management

Power Failure Management plays a crucial role when power supply becomes unstable. Power disruption may occur when users are storing data into the SSD, leading to instability in the drive. However, with Power Failure Management, a firmware protection mechanism will be activated to scan pages and blocks once power is resumed. Valid data will be transferred to new blocks for merging and the mapping table will be rebuilt. Therefore, data reliability can be reinforced, preventing damage to data stored in the NAND Flash.

5.7 TRIM

TRIM is a SATA command that helps improve the read/write performance and efficiency of solid-state drives (SSD). The command enables the host operating system to inform SSD controller which blocks contain invalid data, mostly because of the erase commands from host. The invalid will be discarded permanently and the SSD will retain more space for itself.

5.8 Device Sleep (DevSleep or DEVSLP) Mode (optional)

Device Sleep is a feature that allows SATA devices to enter a low power mode by designating a particular pin as DEVSLP signal with an aim to reducing power consumption.

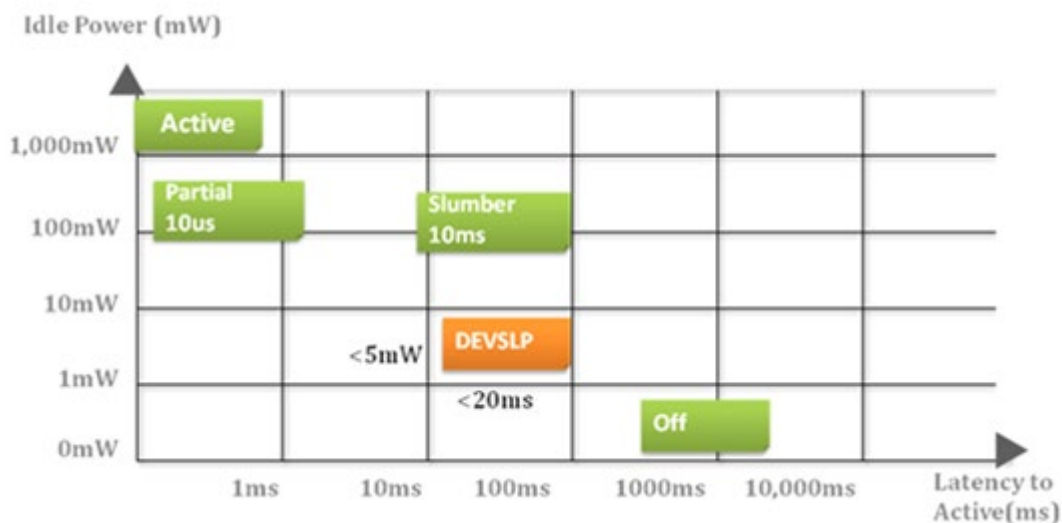

Figure 5-1 Device Sleep

5.9 SATA Power Management

By complying with SATA 6 Gb/s specifications, the SSD supports the following SATA power saving modes:

- ACTIVE: PHY ready, full power, TX & RX operational
- PARTIAL: Reduces power, resumes in under 10 μ s (microseconds)
- SLUMBER: Reduces power, resumes in under 10 ms (milliseconds)
- HIPM: Host-Initiated Power Management
- DIPM: Device-Initiated Power Management
- AUTO-SLUMBER: Automatic transition from partial to slumber.
- Device Sleep (DevSleep or DEVSLP): PHY powered down; power consumption \leq 5 mW; host assertion time \leq 10 ms; exit timeout from this state \leq 20 ms (unless specified otherwise in SATA Identify Device Log).

Notes:

1. The behaviors of power management features would depend on host/device settings.
2. Device Sleep mode is optional depending on product ordering selections.

6. Software Interface

6.1 Command Set

This section defines the software requirements and the format of the commands the host sends to SM220-CFast. Commands are issued to SM220-CFast by loading the required registers in the command block with the supplied parameters, and then writing the command code to the Command register.

Table 6-1 Command Set

Code	Command	Code	Command
E5h	CHECK POWER MODE	F4h	SECURITY ERASE UNIT
06h	DATA SET MANAGEMENT	F5h	SECURITY FREEZE LOCK
92h	DOWNLOAD MICROCODE	F1h	SECURITY SET PASSWORD
90h	EXECUTE DEVICE DIAGNOSTIC	F2h	SECURITY UNLOCK
E7h	FLUSH CACHE	70h	SEEK
EAh	FLUSH CACHE EXT	EFh	SET FEATURES
ECh	IDENTIFY DEVICE	C6h	SET MULTIPLE MODE
E3h	IDLE	E6h	SLEEP
E1h	IDLE IMMEDIATE	B0h	SMART
91h	INITIALIZE DEVICE PARAMETERS	E2h	STANDBY
E4h	READ BUFFER	E0h	STANDBY IMMEDIATE
C8h	READ DMA	E8h	WRITE BUFFER
25h	READ DMA EXT	CAh	WRITE DMA
60h	READ FPDMA QUEUED	35h	WRITE DMA EXT
C4h	READ MULTIPLE	3Dh	WRITE DMA FUA EXT
29h	READ MULTIPLE EXT	61h	WRITE FPDMA QUEUED
2Fh	READ LOG EXT	3Fh	WRITE LOG EXT
47h	READ LOG DMA EXT	57h	WRITE LOG DMA EXT
20h	READ SECTOR	C5h	WRITE MULTIPLE
24h	READ SECTOR EXT	39h	WRITE MULTIPLE EXT
40h	READ VERIFY SECTORS	CEh	WRITE MULTIPLE FUA EXT
42h	READ VERIFY SECTORS EXT	30h	WRITE SECTOR
10h	RECALIBRATE	34h	WRITE SECTOR EXT
F6h	SECURITY DISABLE PASSWORD	45h	WRITE UNCORRECTABLE EXT
F3h	SECURITY ERASE PREPARE		

6.2 S.M.A.R.T.

SMART, an acronym for Self-Monitoring, Analysis and Reporting Technology, is an open standard that allows a hard disk drive to automatically detect its health and report potential failures. When a failure is recorded by SMART, users can choose to replace the drive to prevent unexpected outage or data loss. Moreover, SMART can inform users of impending failures while there is still time to perform proactive actions, such as copy data to another device.

Table 6-2 SMART Subcommand Set

Code	SMART Subcommand
D0h	READ DATA
D1h	READ ATTRIBUTE THRESHOLDS
D2h	ENABLE/DISABLE ATTRIBUTE AUTOSAVE
D4h	EXECUTE OFF-LINE IMMEDIATE
D5h	SMART READ LOG
D6h	SMART WRITE LOG
D8h	ENABLE OPERATIONS
D9h	DISABLE OPERATIONS
DAh	RETURN STATUS

Table 6-3 General SMART Attribute Structure

Byte	Description
0	ID (Hex)
1 – 2	Status Flag
3	Value
4	Worst
5*-11	Raw Data

*Byte 5: LSB

Table 6-4 SMART Attribute ID List

ID (Hex)	Attribute Name
9 (0x09)	Power-on Hours
12 (0x0C)	Power Cycle Count
163 (0xA3)	Maximum Erase Count
164 (0xA4)	Average Erase Count
166 (0xA6)	Total Later Bad Block Count
167 (0xA7)	SSD Protect Mode (Vendor Specific)
168 (0xA8)	SATA PHY Error Count
171 (0xAB)	Program Fail Count
172 (0xAC)	Erase Fail Count
175 (0xAF)	Bad Cluster Table Count
192 (0xC0)	Unexpected Power Loss Count
194 (0xC2)	Temperature
231 (0xE7)	Lifetime Left
241 (0xF1)	Total Sectors of Write

7. Electrical Specifications

7.1 Operating Voltage

Table 7-1 lists the supply voltage for SM220-CFast.

Table 7-1 Operating Range

Parameter	Symbol	Min	Type	Max	Units
Power Supply	Vcc	3.135	3.3	3.465	V

7.2 Power Consumption

Table 7-2 lists the power consumption for SM220-CFast.

Table 7-2 Power Consumption

Mode \ Capacity	Unit	8 GB	16 GB	32 GB	64 GB	128 GB	256 GB
		Active (Max.)	195	230	300	320	435
Idle	mA	85	85	85	80	85	85

Notes:

- All values are typical and may vary depending on flash configurations or host system settings.
- Power consumption is measured using CrystalDiskMark 5.2.1 with file size 1,000MB.

8. Mechanical Specifications

8.1 Physical Dimensions

Table 8-1 Physical Dimensions

Parameter	Unit	8 GB	16 GB	32 GB	64 GB	128 GB	256 GB
Length	mm	42.80 ± 0.10					
Width		36.45 + 0.10/-0.20					
Height (Max.)		3.60					

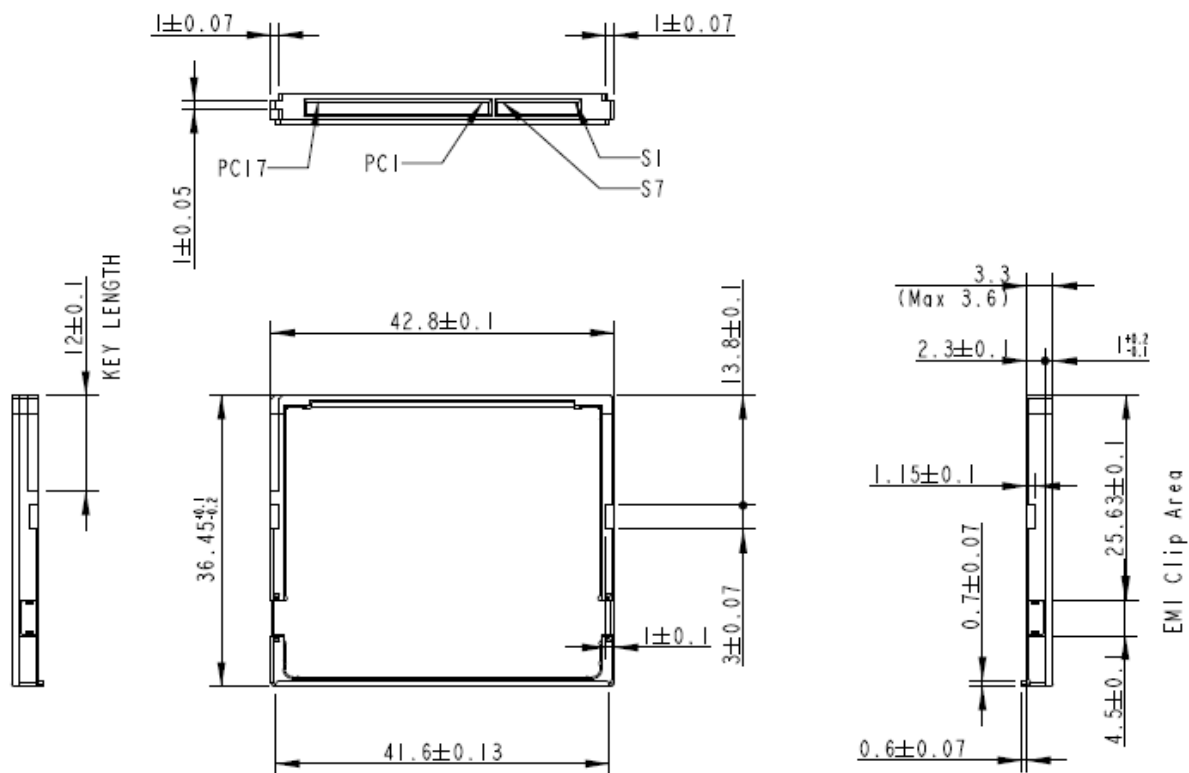

Figure 8-1 Physical Dimensions

8.2 Write Protect Switch (optional)

Apacer implements the Virtual Write scheme that allows write commands to go through the flash controller and data temporarily stored, but no data has been actually written into the flash. Once the system is reset and rebooted, the temporarily stored data will be lost and nowhere to be found in the system. Since the Virtual Write scheme runs at device level, it requires no software or driver installation and is independent from the host OS.

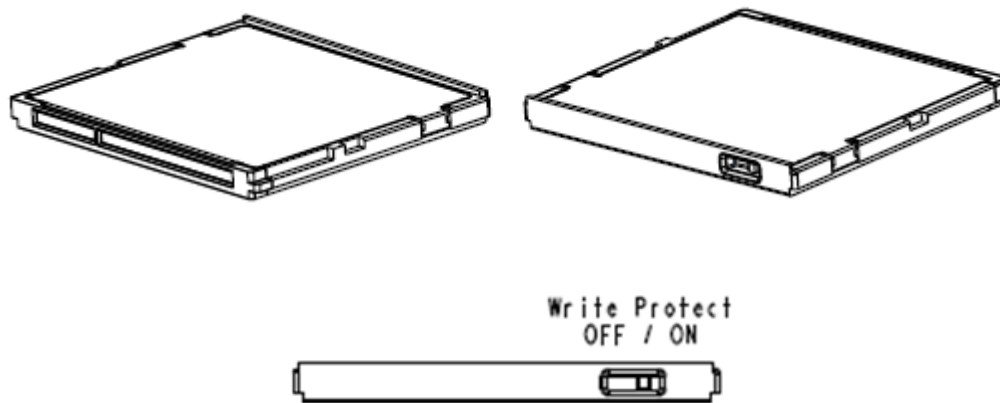
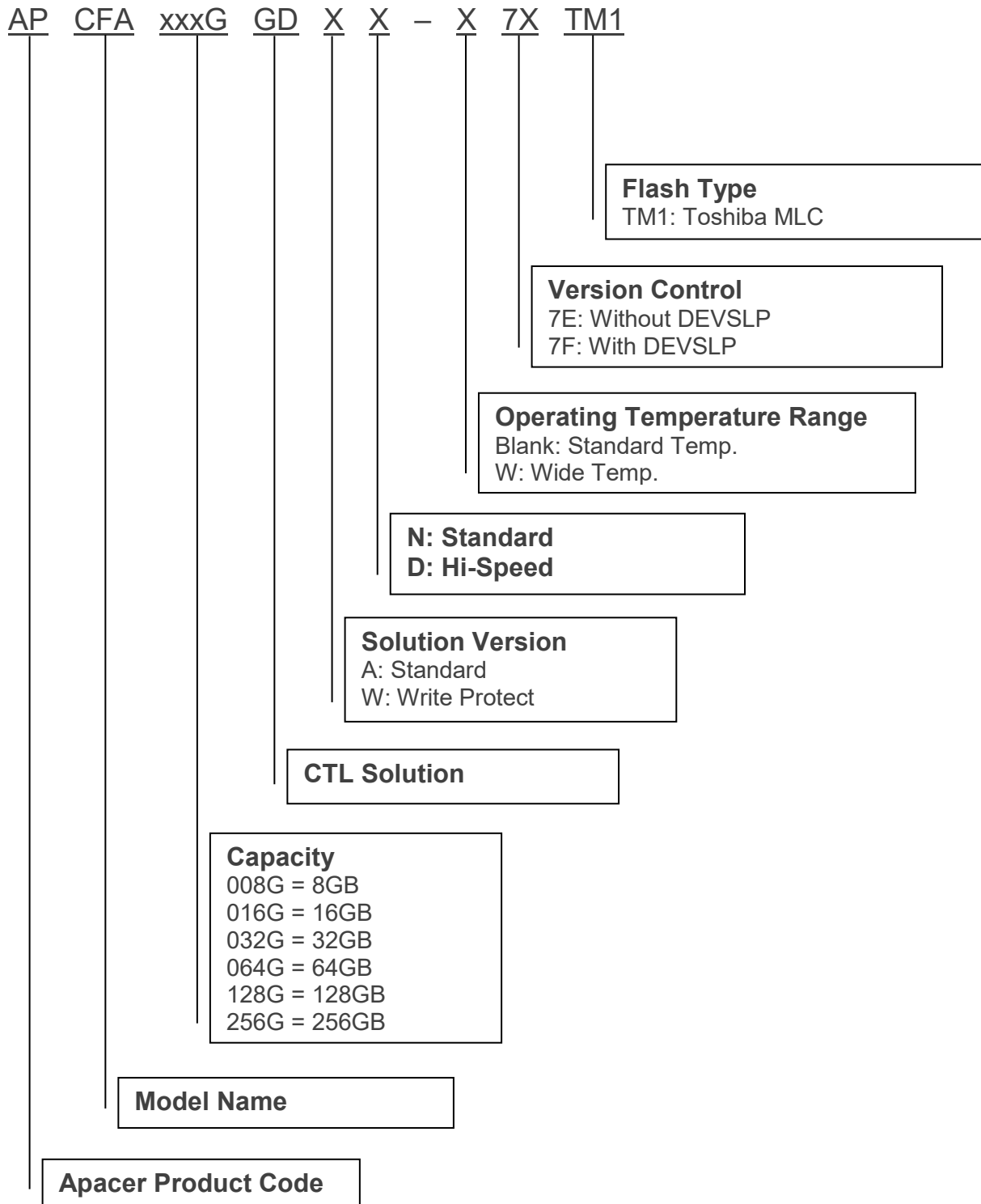

Figure 8-2 Write Protect Switch

9. Product Ordering Information

9.1 Product Code Designations



9.2 Valid Combinations

The following tables list the available models of the SM220-CFast series which are in mass production or will be in mass production. Consult your Apacer sales representative to confirm availability of valid combinations and to determine availability of new combinations.

9.2.1 Without DEVSLP

Capacity	Standard Temperature	Wide Temperature
8GB	APCFA008GGDAN-7ETM1	APCFA008GGDAN-W7ETM1
16GB	APCFA016GGDAN-7ETM1	APCFA016GGDAN-W7ETM1
32GB	APCFA032GGDAD-7ETM1	APCFA032GGDAD-W7ETM1
64GB	APCFA064GGDAD-7ETM1	APCFA064GGDAD-W7ETM1
128GB	APCFA128GGDAD-7ETM1	APCFA128GGDAD-W7ETM1
256GB	APCFA256GGDAD-7ETM1	APCFA256GGDAD-W7ETM1

9.2.2 With DEVSLP

Capacity	Standard Temperature	Wide Temperature
8GB	APCFA008GGDAN-7FTM1	APCFA008GGDAN-W7FTM1
16GB	APCFA016GGDAN-7FTM1	APCFA016GGDAN-W7FTM1
32GB	APCFA032GGDAD-7FTM1	APCFA032GGDAD-W7FTM1
64GB	APCFA064GGDAD-7FTM1	APCFA064GGDAD-W7FTM1
128GB	APCFA128GGDAD-7FTM1	APCFA128GGDAD-W7FTM1
256GB	APCFA256GGDAD-7FTM1	APCFA256GGDAD-W7FTM1

9.2.3 Without DEVSLP+ Write Protect

Capacity	Standard Temperature	Wide Temperature
8GB	APCFA008GGDWN-7ETM1	APCFA008GGDWN-W7ETM1
16GB	APCFA016GGDWN-7ETM1	APCFA016GGDWN-W7ETM1
32GB	APCFA032GGDWD-7ETM1	APCFA032GGDWD-W7ETM1
64GB	APCFA064GGDWD-7ETM1	APCFA064GGDWD-W7ETM1
128GB	APCFA128GGDWD-7ETM1	APCFA128GGDWD-W7ETM1
256GB	APCFA256GGDWD-7ETM1	APCFA256GGDWD-W7ETM1

9.2.4 With DEVSLP+ Write Protect

Capacity	Standard Temperature	Wide Temperature
8GB	APCFA008GGDWN-7FTM1	APCFA008GGDWN-W7FTM1
16GB	APCFA016GGDWN-7FTM1	APCFA016GGDWN-W7FTM1
32GB	APCFA032GGDWD-7FTM1	APCFA032GGDWD-W7FTM1
64GB	APCFA064GGDWD-7FTM1	APCFA064GGDWD-W7FTM1
128GB	APCFA128GGDWD-7FTM1	APCFA128GGDWD-W7FTM1
256GB	APCFA256GGDWD-7FTM1	APCFA256GGDWD-W7FTM1

Revision History

Revision	Description	Date
1.0	Initial release	1/12/2024

Global Presence

Taiwan (Headquarters)

Apacer Technology Inc.

1F., No.32, Zhongcheng Rd., Tucheng Dist.,
New Taipei City 236, Taiwan R.O.C.
Tel: 886-2-2267-8000
Fax: 886-2-2267-2261
amtsales@apacer.com

U.S.A.

Apacer Memory America, Inc.

46732 Lakeview Blvd., Fremont, CA 94538
Tel: 1-408-518-8699
Fax: 1-510-249-9551
sa@apacerus.com

Japan

Apacer Technology Corp.

6F, Daiyontamachi Bldg., 2-17-12, Shibaura, Minato-Ku,
Tokyo, 108-0023, Japan
Tel: 81-3-5419-2668
Fax: 81-3-5419-0018
jpservices@apacer.com

Europe

Apacer Technology B.V.

Science Park Eindhoven 5051 5692 EB Son,
The Netherlands
Tel: 31-40-267-0000
Fax: 31-40-290-0686
sales@apacer.nl

China

Apacer Electronic (Shanghai) Co., Ltd

Room D, 22/FL, No.2, Lane 600, JieyunPlaza,
Tianshan RD, Shanghai, 200051, China
Tel: 86-21-6228-9939
Fax: 86-21-6228-9936
sales@apacer.com.cn

India

Apacer Technologies Pvt Ltd,

1874, South End C Cross, 9th Block Jayanagar,
Bangalore-560069, India
Tel: 91-80-4152-9061/62
Fax: 91-80-4170-0215
sales_india@apacer.com