

RoHS Compliant

CFast 2.0

ST170-CFast 2.0 Product Specifications



May 25, 2020

Version 1.3



Apacer Technology Inc.

1F, No.32, Zhongcheng Rd., Tucheng Dist., New Taipei City, Taiwan, R.O.C

Tel: +886-2-2267-8000 Fax: +886-2-2267-2261

www.apacer.com

Specifications Overview:

- **Compliance with SATA Interface**
 - Serial ATA Revision 3.2
 - SATA 6 Gb/s
 - ATA-8 command set
 - Backward compatible with SATA 1.5/3 Gb/s
- **Capacity**
 - 30, 60, 120, 240, 480 GB
- **Performance***
 - Burst read/write: 600 MB/sec
 - Sequential read: Up to 560 MB/sec
 - Sequential write: Up to 500 MB/sec
 - Random read (4K): Up to 79,000 IOPS
 - Random write (4K): Up to 82,000 IOPS
- **Flash Management**
 - Low-Density Parity-Check (LDPC) Code
 - Global Wear Leveling
 - Flash bad-block management
 - Flash Translation Layer: Page Mapping
 - S.M.A.R.T.
 - DataDefender™
 - Device Sleep
 - ATA Secure Erase
 - TRIM
 - Hyper Cache Technology
 - Over-Provisioning
- **NAND Flash Type:** 3D TLC (BiCS3)
- **MTBF:** >1,000,000 hours
- **Temperature Range**
 - Operating: 0°C to 70°C
 - Storage: -40°C to 100°C
- **Power Consumption***
 - Supply voltage: 3.3V
 - Active mode: 475 mA
 - Idle mode: 105 mA
- **Form Factor**
 - CFast
 - Dimensions: 42.80 x 36.45 x 3.60, unit: mm
 - Net Weight: 9.33 g ± 5%
- **Connector Type**
 - 7 + 17 pin female connector
- **Shock & Vibration****
 - Shock: 1,500 G
 - Vibration: 15 G
- **Endurance (in drive writes per day: DWPD)**
 - 30 GB: 2.4 DWPD
 - 60 GB: 2.4 DWPD
 - 120 GB: 2.4 DWPD
 - 240 GB: 2.4 DWPD
 - 480 GB: 3.0 DWPD
- **Reliability**
 - Thermal Sensor
 - End-to-End Data Protection
- **RoHS Compliant**

*Varies from capacities. The values for performances and power consumptions presented are typical and may vary depending on flash configurations or platform settings.

**Non-operating

Table of Contents

1. General Descriptions	4
2. Functional Block	4
3. Pin Assignments.....	5
4. Product Specifications.....	7
4.1 Capacity.....	7
4.2 Performance	7
4.3 Environmental Specifications	8
4.4 Mean Time Between Failures (MTBF)	8
4.5 Certification and Compliance.....	8
4.6 Endurance	9
5. Flash Management	10
5.1 Error Correction/Detection.....	10
5.2 Bad Block Management	10
5.3 Global Wear Leveling	10
5.4 Flash Translation Layer – Page Mapping.....	10
5.5 ATA Secure Erase.....	11
5.6 DataDefender™.....	11
5.7 TRIM.....	11
5.8 Hyper Cache Technology	11
5.9 Over-Provisioning	11
5.10 DEVSLP (DevSleep or DEVSLP) Mode (optional).....	12
5.11 SATA Power Management.....	12
6. Reliability Features	13
6.1 End-to-End Data Protection.....	13
6.2 Thermal Sensor	13
7. Software Interface	14
7.1 Command Set.....	14
7.2 S.M.A.R.T.	14
8. Electrical Specifications.....	16
8.1 Operating Voltage.....	16

8.2 Power Consumption	16
9. Physical Characteristics.....	17
9.1 Dimensions	17
9.2 Net Weight.....	17
10. Product Ordering Information.....	18
10.1 Product Code Designations.....	18
10.2 Valid Combinations.....	19

1. General Descriptions

Apacer ST170-CFast 2.0 is the latest enhancement of conventional CFast form factor that delivers various technological advantages. It utilizes 3D NAND for higher capacity up to 480 GB and provides more power efficiency than 2D NAND. This new flash memory card comes with SATA 6 Gb/s interface for higher performance and consists of SATA-based 7-pin signal segment and 17-pin for power and control purposes. Designed without DRAM on the internal controlling unit, ST170-CFast ensures data integrity by preventing data loss during a sudden power outage.

For data efficiency, ST170-CFast 2.0 delivers data transfer rates up to 560 MB/s in sequential access and 79,000 IOPS in 4KB random access. In addition, Apacer CFast cards come with S.M.A.R.T. for lifetime monitoring. Apacer ST170-CFast 2.0 guarantees reliability of applications in harsh environments by implementing intelligent Flash Management algorithms and LDPC (Low Density Parity Check) ECC engine to extend SSD endurance and increase data reliability while reading raw data inside a flash chip.

2. Functional Block

Apacer ST170-CFast 2.0 includes a single-chip SATA 6 Gb/s and the flash media. The controller integrates the flash management unit to support multi-channel, multi-bank flash arrays. Figure 2-1 shows the functional block diagram.

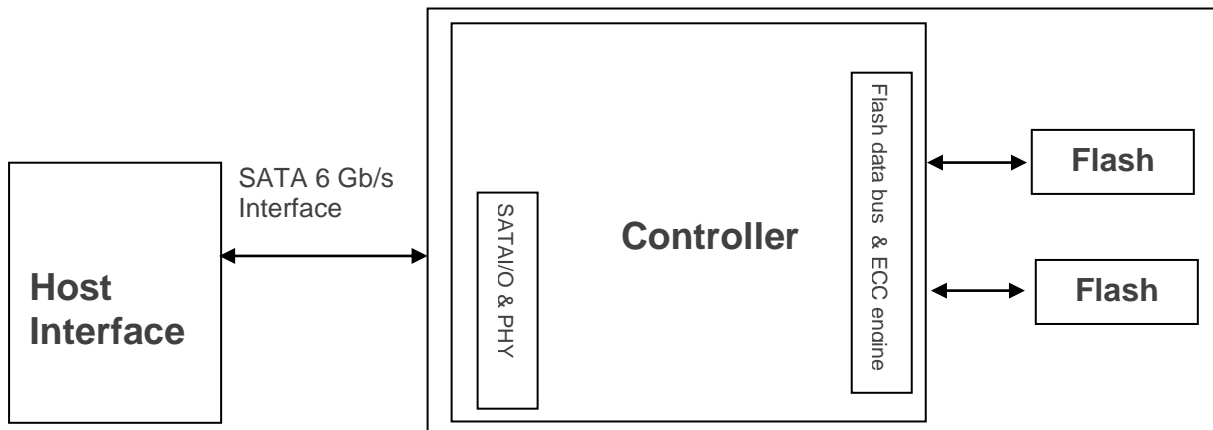

Figure 2-1 Functional Block Diagram

3. Pin Assignments

Table 3-1 describes ST170-CFast 2.0 signal segment, and Table 3-2, its power segment.

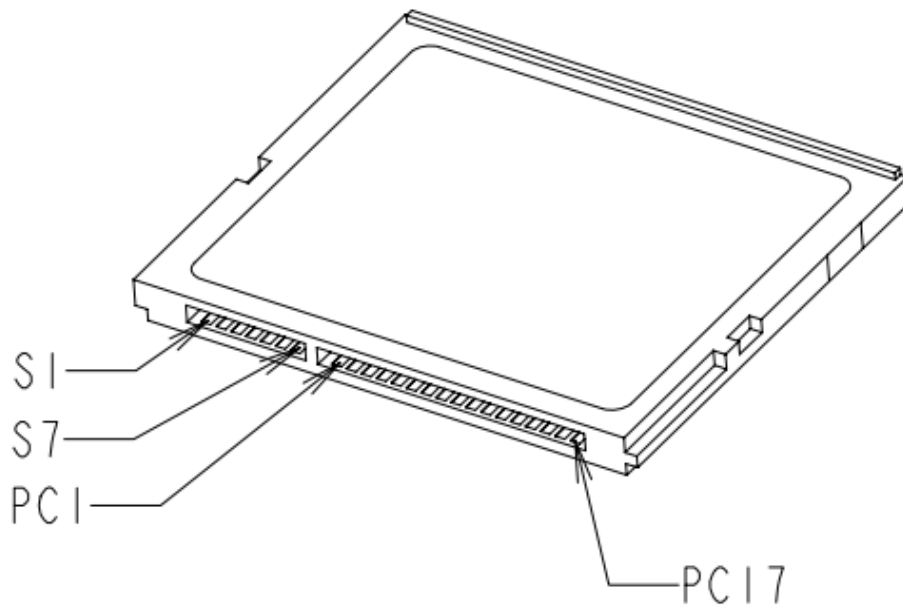

Figure 3-1 Pin Assignment

Table 3-1 Signal Segment

Pin	Definition	Description
S1	GND	Ground
S2	A+	SATA Differential Signal Pair A
S3	A-	
S4	GND	Ground
S5	B-	SATA Differential Signal Pair B
S6	B+	
S7	GND	Ground

Table 3-2 Power Segment

Pin	Definition	Type	Description
PC1	CDI	Input	Card Detect In
PC2	PGND	Device GND	Device GND
PC3	DEVSLP*	DEVSLP card input	DEVSLP enable
PC4			Reserved
PC5			Reserved
PC6			Reserved
PC7	PGND	Device GND	Device GND
PC8	LED1	LED Output	Power indicator
PC9	LED2	LED Output	Access indicator
PC10			Reserved
PC11			Reserved
PC12	IFDet	GND	Card output, connect to PGND on card
PC13	PWR	3.3V	Device power (3.3V)
PC14	PWR	3.3V	Device power (3.3V)
PC15	PGND	Device GND	Device GND
PC16	PGND	Device GND	Device GND
PC17	CDO	Output	Card Detect Out

*Optional

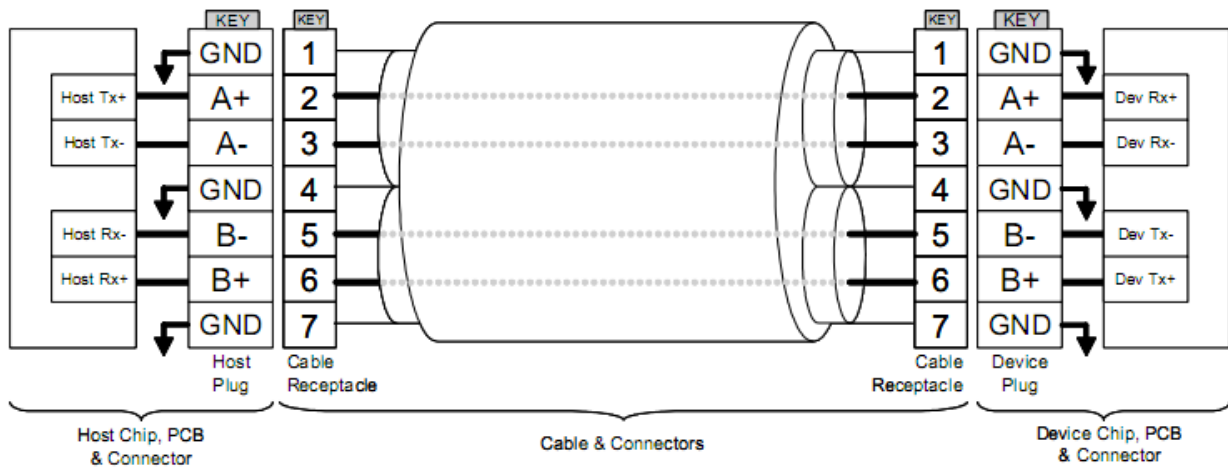

Figure 3-2 SATA Cable / Connector Connection Diagram

The connector on the left represents the Host with TX/RX differential pairs connected to a cable while the connector on the right shows the Device with TX/RX differential pairs also connected to the cable. Notice also the ground path connecting the shielding of the cable to the Cable Receptacle.

4. Product Specifications

4.1 Capacity

Capacity specifications of the ST170-CFast 2.0 are available as shown in Table 4-1. It lists the specific capacity and the default numbers of heads, sectors and cylinders for each product line.

Table 4-1 Capacity Specifications

Capacity	Total bytes*	Cylinders	Heads	Sectors	Max LBA
30 GB	30,016,659,456	16,383	16	63	58,626,288
60 GB	60,022,480,896	16,383	16	63	117,231,408
120 GB	120,034,123,776	16,383	16	63	234,441,648
240 GB	240,057,409,536	16,383	16	63	468,862,128
480 GB	480,103,981,056	16,383	16	63	937,703,088

*Display of total bytes varies from file systems, which means not all of the bytes can be used for storage.

**Notes: 1 GB = 1,000,000,000 bytes; 1 sector = 512 bytes.

LBA count addressed in the table above indicates total user storage capacity and will remain the same throughout the lifespan of the device. However, the total usable capacity of the SSD is most likely to be less than the total physical capacity because a small portion of the capacity is reserved for device maintenance usages.

4.2 Performance

Performance of ST170-CFast 2.0 product family is available as shown in Table 4-2.

Table 4-2 Performance Specifications

Performance	Capacity	30 GB	60 GB	120 GB	240 GB	480 GB
	Sequential Read* (MB/s)		295	555	560	560
Sequential Write* (MB/s)		130	255	450	495	500
Random Read IOPS** (4K)		20,000	39,000	70,000	79,000	79,000
Random Write IOPS** (4K)		30,000	58,000	77,000	82,000	82,000

Note:

Results may differ from various flash configurations or host system setting.

*Sequential performance is based on CrystalDiskMark 5.2.1 with file size 1,000MB.

**Random performance measured using IOMeter with Queue Depth 32.

4.3 Environmental Specifications

Environmental specifications of ST170-CFast 2.0 are shown in Table 4-3.

Table 4-3 Environmental Specifications

Item	Specifications
Operating temp.	0°C to 70°C
Non-operating temp.	-40°C to 100°C
Operating vibration	7.69 GRMS, 20~2000 Hz/random (compliant with MIL-STD-810G)
Non-operating vibration	4.02 GRMS, 15~2000 Hz/random (compliant with MIL-STD-810G)
Operating shock	50G, 11ms
Non-operating shock	1500G, 0.5ms (compliant with MIL-STD-883K)

Note: This Environmental Specification table indicates the conditions for testing the device. Real world usages may affect the results.

4.4 Mean Time Between Failures (MTBF)

Mean Time Between Failures (MTBF) is predicted based on reliability data for the individual components in ST170-CFast 2.0. Serving as statistical reference, the prediction result for ST170-CFast is more than 1,000,000 hours.

Note: The MTBF is predicated and calculated based on “Telcordia Technologies Special Report, SR-332, Issue 2” method.

4.5 Certification and Compliance

ST170-CFast 2.0 complies with the following standards:

- CE
- FCC
- RoHS
- MIL-STD-810G

4.6 Endurance

The endurance of a storage device is predicted by Drive Writes Per Day based on several factors related to usage, such as the amount of data written into the drive, block management conditions, and daily workload for the drive. Thus, key factors, such as Write Amplifications and the number of P/E cycles, can influence the lifespan of the drive.

Table 4-4 Drive Writes Per Day

Capacity	Drive Writes Per Day
30 GB	2.4
60 GB	2.4
120 GB	2.4
240 GB	2.4
480 GB	3.0

Note:

- This estimation complies with JEDEC random client workload.
- Flash vendor guaranteed 3D NAND TLC P/E cycle: 3K
- WAF may vary from capacity, flash configurations and writing behavior on each platform.
- 1 Terabyte = 1,024GB
- DWPD (Drive Writes Per Day) is calculated the number of times that user can overwrite the entire capacity of an SSD per day of its lifetime during the warranty period. (3D NAND TLC warranty: 2 years)

5. Flash Management

5.1 Error Correction/Detection

ST170-CFast implements a hardware ECC scheme, based on the Low Density Parity Check (LDPC). LDPC is a class of linear block error correcting code which has apparent coding gain over BCH code because LDPC code includes both hard decoding and soft decoding algorithms. With the error rate decreasing, LDPC can extend SSD endurance and increase data reliability while reading raw data inside a flash chip.

5.2 Bad Block Management

Current production technology is unable to guarantee total reliability of NAND flash memory array. When a flash memory device leaves factory, it comes with a minimal number of initial bad blocks during production or out-of-factory as there is no currently known technology that produce flash chips free of bad blocks. In addition, bad blocks may develop during program/erase cycles. When host performs program/erase command on a block, bad block may appear in Status Register. Since bad blocks are inevitable, the solution is to keep them in control. Apacer flash devices are programmed with ECC, page mapping technique and S.M.A.R.T to reduce invalidity or error. Once bad blocks are detected, data in those blocks will be transferred to free blocks and error will be corrected by designated algorithms.

5.3 Global Wear Leveling

Flash memory devices differ from Hard Disk Drives (HDDs) in terms of how blocks are utilized. For HDDs, when a change is made to stored data, like erase or update, the controller mechanism on HDDs will perform overwrites on blocks. Unlike HDDs, flash blocks cannot be overwritten and each P/E cycle wears down the lifespan of blocks gradually. Repeatedly program/erase cycles performed on the same memory cells will eventually cause some blocks to age faster than others. This would bring flash storages to their end of service term sooner. Global wear leveling is an important mechanism that levels out the wearing of all blocks so that the wearing-down of all blocks can be almost evenly distributed. This will increase the lifespan of SSDs.

5.4 Flash Translation Layer – Page Mapping

Page mapping is an advanced flash management technology whose essence lies in the ability to gather data, distribute the data into flash pages automatically, and then schedule the data to be evenly written. Page-level mapping uses one page as the unit of mapping. The most important characteristic is that each logical page can be mapped to any physical page on the flash memory device. This mapping algorithm allows different sizes of data to be written to a block as if the data is written to a data pool and it does not need to take extra operations to process a write command. Thus, page mapping is adopted to increase random access speed and improve SSD lifespan, reduce block erase frequency, and achieve optimized performance and lifespan.

5.5 ATA Secure Erase

ATA Secure Erase is an ATA disk purging command currently embedded in most of the storage drives. Defined in ATA specifications, (ATA) Secure Erase is part of Security Feature Set that allows storage drives to erase all user data areas. The erase process usually runs on the firmware level as most of the ATA-based storage media currently in the market are built-in with this command. ATA Secure Erase can securely wipe out the user data in the drive and protects it from malicious attack.

5.6 DataDefender™

Apacer's DataDefender combines both firmware and hardware mechanisms to ensure data integrity. When power disruption occurs, the hardware mechanism will notice and trigger the controller to run multiple write-to-flash cycles to store data. Then the firmware will check that the data was correctly written to the NAND flash after the power disruption, preventing data loss.

5.7 TRIM

TRIM is a SATA command that helps improve the read/write performance and efficiency of solid-state drives (SSD). The command enables the host operating system to inform SSD controller which blocks contain invalid data, mostly because of the erase commands from host. The invalid will be discarded permanently and the SSD will retain more space for itself.

5.8 Hyper Cache Technology

Apacer proprietary Hyper Cache technology uses a portion of the available capacity as SLC (1bit-per-cell) NAND flash memory, called Hyper cache mode. When data is written to SSD, the firmware will direct the data to Hyper Cache mode, providing excellent performance to handle various scenarios in industrial use.

5.9 Over-Provisioning

Over-Provisioning (OP) is a certain portion of the SSD capacity exclusively for increasing Garbage Collection (GC) efficiency, especially when the SSD is filled to full capacity or performs a heavy mixed-random workload. OP has the advantages of providing extended life expectancy, reliable data integrity, and high sustained write performance.

5.10 DEVSLP (DevSleep or DEVSLP) Mode (optional)

Device Sleep is a feature that allows SATA devices to enter a low power mode by designating a particular pin as DEVSLP signal with an aim to reducing power consumption.

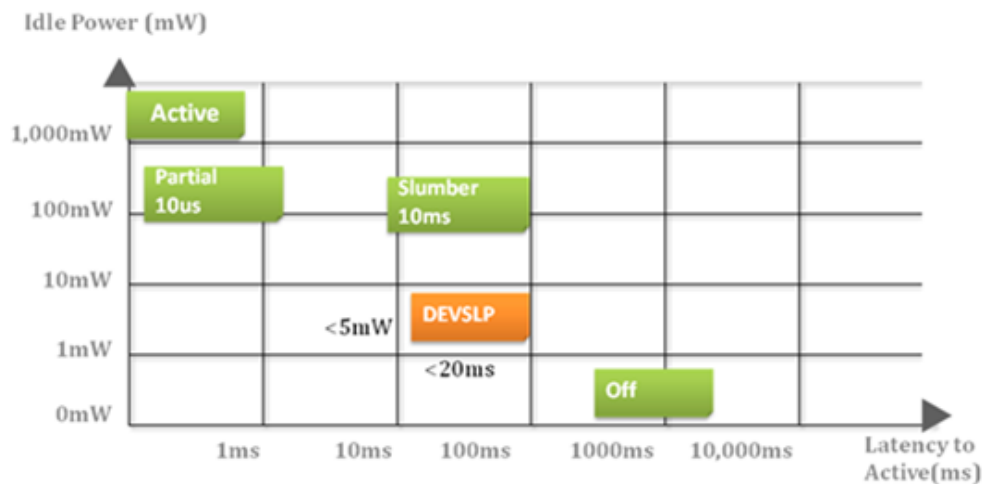

5.11 SATA Power Management

By complying with SATA 6 Gb/s specifications, the SSD supports the following SATA power saving modes:

- ACTIVE: PHY ready, full power, Tx & Rx operational
- PARTIAL: Reduces power, resumes in under 10 μs (microseconds)
- SLUMBER: Reduces power, resumes in under 10 ms (milliseconds)
- HIPM: Host-Initiated Power Management
- DIPM: Device-Initiated Power Management
- AUTO-SLUMBER: Automatic transition from partial to slumber.

Note: The behaviors of power management features would depend on host/device settings.

6. Reliability Features

6.1 End-to-End Data Protection

End-to-End Data Protection is a feature implemented in Apacer SSD products that extends error control to cover the entire path from the host computer to the drive and back, and ensure data integrity at multiple points in the path to enable reliable delivery of data transfers. Unlike ECC which does not exhibit the ability to determine the occurrence of errors throughout the process of data transmission, End-to-End Data Protection allows SSD controller to identify an error created anywhere in the path and report the error to the host computer before it is written to the drive. This error-checking and error-reporting mechanism therefore guarantees the trustworthiness and reliability of the SSD.

6.2 Thermal Sensor

Apacer Thermal Sensor is a digital temperature sensor with serial interface. By using designated pins for transmission, storage device owners are able to read temperature data.

7. Software Interface

7.1 Command Set

Table 7-1 Command Set

Code	Command	Code	Command
E5h	CHECK POWER MODE	F6h	SECURITY DISABLE PASSWORD
90h	EXECUTE DIAGNOSTICS	F3h	SECURITY ERASE PREPARE
E7h	FLUSH CACHE	F4h	SECURITY ERASE UNIT
ECh	IDENTIFY DEVICE	F5h	SECURITY FREEZE LOCK
E3h	IDLE	F1h	SECURITY SET PASSWORD
E1h	IDLE IMMEDIATE	F2h	SECURITY UNLOCK
91h	INITIALIZE DEVICE PARAMETERS	7Xh	SEEK
C8h	READ DMA	EFh	SET FEATURES
25h	READ DMA EXT	C6h	SET MULTIPLE MODE
60h	READ FPDMA QUEUED	E6h	SLEEP
47h	READ LOG DMA EXT	B0h	S.M.A.R.T.
2Fh	READ LOG EXT	E2h	STANDBY
C4h	READ MULTIPLE	E0h	STANDBY IMMEDIATE
20 or 21h	READ SECTOR(S)	CAh	WRITE DMA
40 or 41h	READ VERIFY SECTOR(S)	35h	WRITE DMA EXT
10h	RECALIBRATE	61h	WRITE FPDMA QUEUED
57h	WRITE LOG DMA EXT	3Fh	WRITE LOG EXT
C5h	WRITE MULTIPLE	30h or 31h	WRITE SECTOR(S)

7.2 S.M.A.R.T.

S.M.A.R.T. is an abbreviation for Self-Monitoring, Analysis and Reporting Technology, a self-monitoring system that provides indicators of drive health as well as potential disk problems. It serves as a warning for users from unscheduled downtime by monitoring and displaying critical drive information. Ideally, this should allow taking proactive actions to prevent drive failure and make use of S.M.A.R.T. information for future product development reference.

Apacer devices use the standard SMART command B0h to read data out from the drive to activate our S.M.A.R.T. feature that complies with the ATA/ATAPI specifications. S.M.A.R.T. Attribute IDs shall include initial bad block count, total later bad block count, maximum erase count, average erase count, power on hours and power cycle. When the S.M.A.R.T. Utility running on the host, it analyzes and reports the disk status to the host before the device reaches in critical condition.

Note: Attribute IDs may vary from product models due to various solution design and supporting capabilities.

Apacer memory products come with S.M.A.R.T. commands and subcommands for users to obtain information of drive status and to predict potential drive failures. Users can take advantage of the following commands/subcommands to monitor the health of the drive.

Code	SMART Subcommand
D0h	READ DATA
D1h	READ ATTRIBUTE THRESHOLDS
D2h	ENABLE/DISABLE ATTRIBUTE AUTOSAVE
D4h	EXECUTE OFF-LINE IMMEDIATE
D5h	SMART READ LOG
D6h	SMART WRITE LOG
D8h	ENABLE OPERATIONS
D9h	DISABLE OPERATIONS
DAh	RETURN STATUS

General SMART attribute structure

Byte	Description
0	ID (Hex)
1 – 2	Status Flag
3	Value
4	Worst
5*-11	Raw Data

*Byte 5: LSB

SMART attribute ID list

ID (Hex)	Attribute Name
9 (0x09)	Power-on Hours
12 (0x0C)	Power Cycle Count
163 (0xA3)	Max. Erase Count
164 (0xA4)	Avg. Erase Count
166 (0xA6)	Total Later Bad Block Count
167 (0xA7)	SSD Protect Mode (Vendor Specific)
168 (0xA8)	SATA PHY Error Count
171 (0xAB)	Program Fail Count
172 (0xAC)	Erase Fail Count
175 (0xAF)	Bad Cluster Table Count
192 (0xC0)	Unexpected Power Loss Count
194 (0xC2)	Temperature
231 (0xE7)	Lifetime Left
241 (0xF1)	Total Sectors of Write

8. Electrical Specifications

8.1 Operating Voltage

Table 8-1 lists the supply voltage for ST170-CFast 2.0.

Table 8-1 Operating Range

Parameter	Symbol	Min	Type	Max	Units
Power Supply	Vcc	3.135	3.3	3.465	V

8.2 Power Consumption

Table 8-2 lists the power consumption for ST170-CFast 2.0.

Table 8-2 Power Consumption

Capacity	30 GB	60 GB	120 GB	240 GB	480 GB
Mode					
Active (mA)	300	395	400	455	475
Idle (mA)	105	105	100	100	100

Note:

*All values are typical and may vary depending on flash configurations or host system settings.

**Active power is an average power measurement performed using CrystalDiskMark with 128KB sequential read/write transfers.

9. Physical Characteristics

9.1 Dimensions

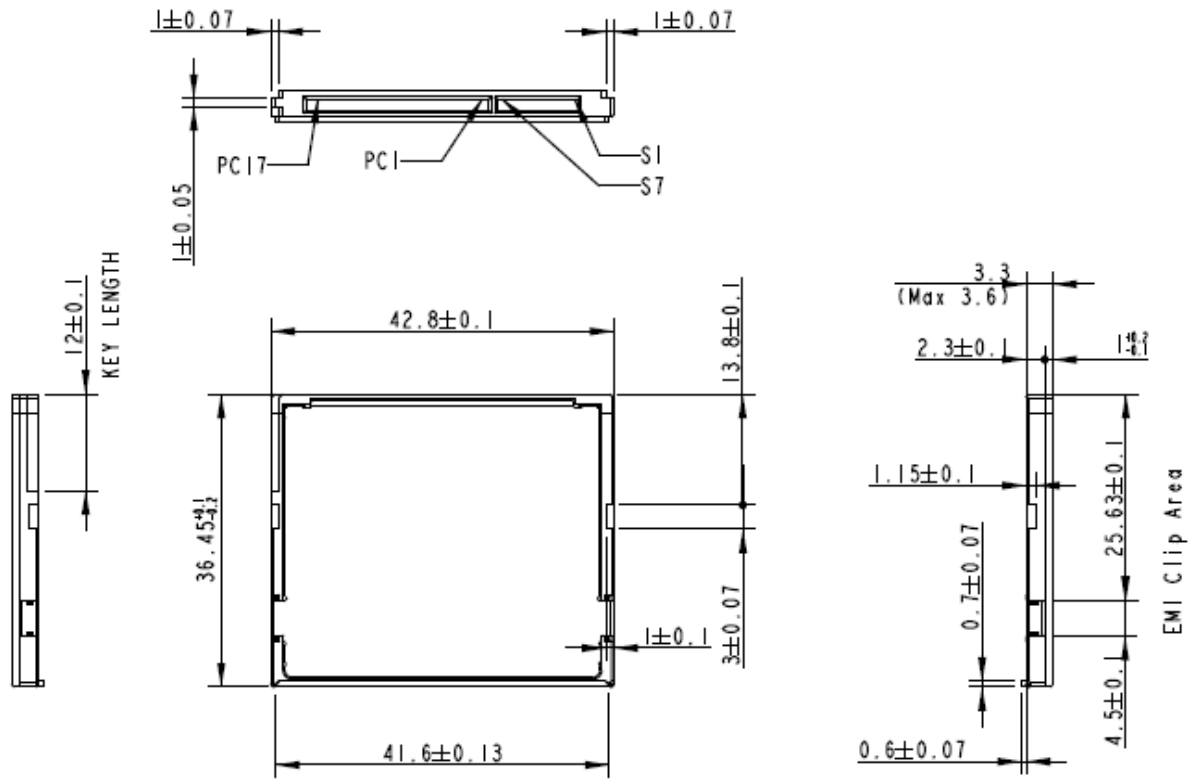

Figure 9-1 Physical Dimensions

Unit: mm

9.2 Net Weight

Table 9-1 Net Weight

Capacity	Net Weight (g ± 5%)
30GB	7.72
60GB	8.23
120GB	9.32
240GB	9.33
480GB	9.32

10. Product Ordering Information

10.1 Product Code Designations

Code	1	2	3	4	5	6	7	8	9	10	11	12	13	14	15	16
	A	A	2	.	1	7	5	X	G	A	.	X	X	X	1	1

Code 1st ~ 3rd (Product Line & form factor)	MDC+CFS
Code 5th ~ 6th (Model/Solution)	ST170
Code 7th ~ 8th (Product Capacity)	5F: 30GB 5G: 60GB 5H: 120GB 5J: 240GB 5K: 480GB
Code 9th (Flash Type & Product Temp)	G: 3D TLC Standard temperature
Code 10th (Product Spec)	A: Standard without Write Protect switch
Code 12th ~ 14th (Version Number)	Random numbers generated by system
Code 15th ~ 16th (Firmware Version)	11: DEVSLP + Thermal Sensor + OP

10.2 Valid Combinations

Capacity	Part Number
30GB	AA2.175FGA.00211
60GB	AA2.175GGA.00211
120GB	AA2.175HGA.00211
240GB	AA2.175JGA.00311
480GB	AA2.175KGA.00211

Note: Valid combinations are those products in mass production or will be in mass production. Consult your Apacer sales representative to confirm availability of valid combinations and to determine availability of new combinations.

Revision History

Revision	Description	Date
1.0	Official release	8/20/2019
1.1	Modified total bytes at Table 4-1 Capacity Specifications	2/10/2020
1.2	<ul style="list-style-type: none">- Changed SATA 6.0 Gbps to SATA 6 Gb/s in accordance with SATA naming guidelines- Updated operating/non-operating vibration spec at Table 4-3 Environmental Specifications- Capitalized every letter for commands at 7.1 Command Set and SMART subcommand at 7.2 S.M.A.R.T.	3/19/2020
1.3	Updated compliance version with SATA Interface from 3.1 to 3.2 on Specifications Overview page	5/25/2020

Global Presence

Taiwan (Headquarters)

Apacer Technology Inc.

1F., No.32, Zhongcheng Rd., Tucheng Dist.,
New Taipei City 236, Taiwan R.O.C.

Tel: 886-2-2267-8000

Fax: 886-2-2267-2261

amtsales@apacer.com

U.S.A.

Apacer Memory America, Inc.

46732 Lakeview Blvd., Fremont, CA 94538

Tel: 1-408-518-8699

Fax: 1-510-249-9551

sa@apacerus.com

Japan

Apacer Technology Corp.

6F, Daiyontamachi Bldg., 2-17-12, Shibaura, Minato-Ku,
Tokyo, 108-0023, Japan

Tel: 81-3-5419-2668

Fax: 81-3-5419-0018

jpservices@apacer.com

Europe

Apacer Technology B.V.

Science Park Eindhoven 5051 5692 EB Son,
The Netherlands

Tel: 31-40-267-0000

Fax: 31-40-290-0686

sales@apacer.nl

China

Apacer Electronic (Shanghai) Co., Ltd

Room D, 22/FL, No.2, Lane 600, JieyunPlaza,
Tianshan RD, Shanghai, 200051, China

Tel: 86-21-6228-9939

Fax: 86-21-6228-9936

sales@apacer.com.cn

India

Apacer Technologies Pvt Ltd,

1874, South End C Cross, 9th Block Jayanagar,
Bangalore-560069, India

Tel: 91-80-4152-9061/62

Fax: 91-80-4170-0215

sales_india@apacer.com