

RoHS Compliant

CFast 2 HS

CFast-M 2 HS HS Product Specifications

February 14th, 2014

Version 1.1



Apacer Technology Inc.

1F, No.32, Zhongcheng Rd., Tucheng Dist., New Taipei City, Taiwan, R.O.C

Tel: +886-2-2267-8000 Fax: +886-2-2267-2261

www.apacer.com

Features:

- **Standard Serial ATA Interface**
 - SATA Revision 3.1 compliance
 - SATA 6.0 Gbps interface speed
 - Backward compatible with SATA 1.5 and 3.0 Gbps interfaces
 - ATA-compatible command set
- **Connector type**
 - 7 + 17 pin female connector
- **Power consumption (typical)***
 - Supply voltage: 3.3V
 - Active mode: 525 mA
 - Idle mode: 140 mA
- **Performance***
 - Sustained read: Up to 310 MB/sec
 - Sustained write: Up to 240 MB/sec
- **Capacity**
 - 16, 32, 64, 128 GB
- **NAND Flash Type: MLC**
- **MTBF: >1,000,000 hours**
- **Temperature ranges**
 - Operating: 0 °C to 70 °C
 - Storage: -40 °C to 100 °C
- **Flash Management**
 - Built-in hardware ECC, enabling up to 40-bit correction per 1K bytes
 - Static/dynamic wear-leveling
 - Flash bad-block management
 - S.M.A.R.T.
 - Power Failure Management
 - ATA Secure Erase
 - TRIM
- **RoHS Compliant**
- **Endurance (in TBW: Terabytes Written)**
 - 16GB: 26 TBW
 - 32GB: 52 TBW
 - 64GB: 104 TBW
 - 128GB: 208 TBW
- **Device Sleep mode (optional)**

*Vary from capacities. The values presented in Power consumption and Performances are typical, and may vary depending on different settings and platforms.

Table of Contents

1. GENERAL DESCRIPTION	3
2. FUNCTIONAL BLOCK	3
3. PIN ASSIGNMENTS	4
4. PRODUCT SPECIFICATIONS	6
4.1 CAPACITY	6
4.2 PERFORMANCE	6
4.3 ENVIRONMENTAL SPECIFICATIONS	6
4.4 MEAN TIME BETWEEN FAILURES (MTBF)	7
4.5 CERTIFICATION AND COMPLIANCE	7
4.6 ENDURANCE	7
5. FLASH MANAGEMENT	8
5.1 ERROR CORRECTION/DETECTION	8
5.2 BAD BLOCK MANAGEMENT	8
5.3 WEAR LEVELING	8
5.4 POWER FAILURE MANAGEMENT	8
5.5 ATA SECURE ERASE	8
5.6 TRIM	9
5.7 SATA POWER MANAGEMENT MODES	9
7. ELECTRICAL SPECIFICATION	12
7.1 OPERATING VOLTAGE	12
7.2 POWER CONSUMPTION	12
8. PHYSICAL CHARACTERISTICS	13
8.1 DIMENSIONS	13
9. PRODUCT ORDERING INFORMATION	14
9.1 PRODUCT CODE DESIGNATIONS	14

1. General Description

Apacer CFast-M 2 HS is the latest enhancement of conventional CFast-M form factor that delivers various technological advantages. This new flash memory card comes with SATA 6.0 Gbps interface for higher performance and is compliant with standard CFast-M specifications. CFast-M 2 HS consists of SATA-based 7-pin signal segment and 17-pin for power and control purposes. It can offer moderate capacity and decent data transfer performance. For power efficiency, this new flash memory card leverages the technological benefits of SATA Revision 3.1 specifications, including Device Sleep. That will greatly reduce power consumption when the device is not in operating mode. For data integrity, the CFast-M card is built with ECC engine correcting up to 40-bit. Together with its small form factor nature, Apacer CFast-M 2 HS is definitely the ideal solution to replace conventional PATA-based CompactFlash for applications in industrial computing systems, mobile computers and video processing instruments.

2. Functional Block

Apacer CFast-M 2 includes a single-chip SATA 6.0 Gbps and the flash media. The controller integrates the flash management unit to support multi-channel, multi-bank flash arrays. Figure 2-1 shows the functional block diagram.

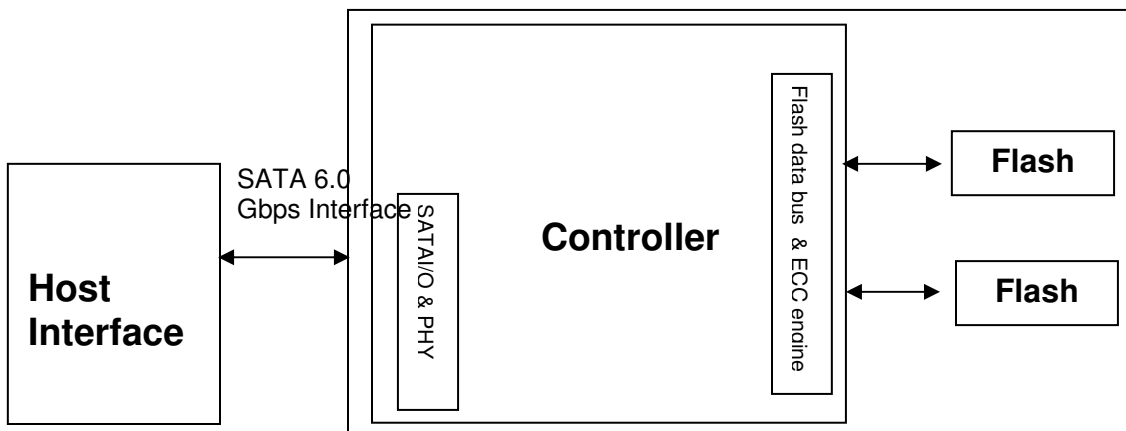

Figure 2-1 Apacer CFast-M block diagram

3. Pin Assignments

Table 3-1 describes CFast-M 2 HS signal segment, and Table 3-2, its power segment.

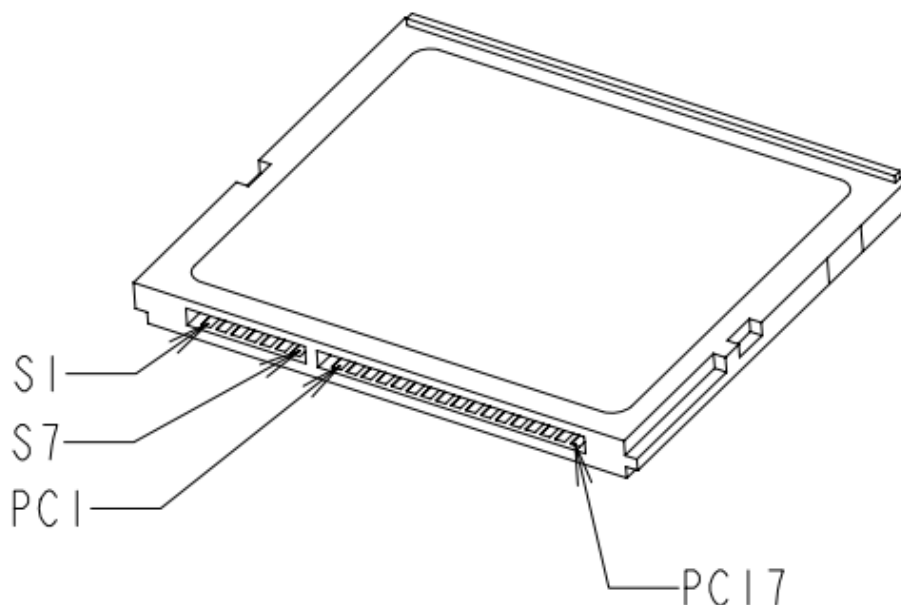

Figure 3-1 Pin Assignment

Table 3-1 Signal Segment

Pin	Definition	Description
S1	GND	Ground
S2	A+	SATA Differential Signal Pair A
S3	A-	
S4	GND	Ground
S5	B-	SATA Differential Signal Pair B
S6	B+	
S7	GND	Ground

Table 3-2 Power Segment

Pin	Definition	Type	Description
PC1	CDI	Input	Card Detect In
PC2	PGND	Device GND	Device GND
PC3	DEVSLP*	DEVSLP card input	DEVSLP enable
PC4			Reserved
PC5			Reserved

CFast-M 2 HS

AP-CFAxxxxACAD-XTM

PC6			Reserved
PC7	PGND	Device GND	Device GND
PC8	LED1	LED Output	Power indicator
PC9	LED2	LED Output	Access indicator
PC10			Reserved
PC11			Write Protect**
PC12	IFDet	GND	Card output, connect to PGND on card
PC13	PWR	3.3V	Device power (3.3V)
PC14	PWR	3.3V	Device power (3.3V)
PC15	PGND	Device GND	Device GND
PC16	PGND	Device GND	Device GND
PC17	CDO	Output	Card Detect Out

*Optional

**Enabled by adjusting the pin "PC11" from high to low active

Notes about Write Protect:

Apacer implements the Virtual Write scheme that allows write commands to go through the flash controller and data is temporarily stored, but no data has been actually written into the flash. Once the host resets or restarts the system, all the temporarily stored data will disappear and nowhere to be found in the drive. Since the Virtual Write scheme runs at device level, it requires no software or driver installation and is independent from the host OS.

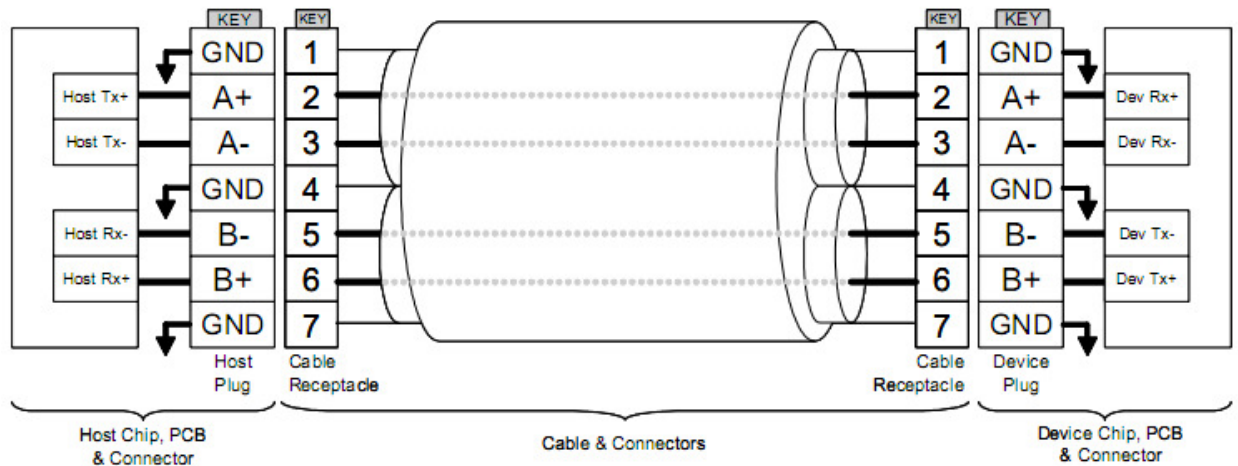

Figure 3-2 SATA Cable / Connector Connection Diagram

The connector on the left represents the Host with TX/RX differential pairs connected to a cable while the connector on the right shows the Device with TX/RX differential pairs also connected to the cable. Notice also the ground path connecting the shielding of the cable to the Cable Receptacle.

4. Product Specifications

4.1 Capacity

Capacity specification of the CFast-M 2 HS is available as shown in Table 4-1. It lists the specific capacity and the default numbers of heads, sectors and cylinders for each product line.

Table 4-1: Capacity specifications

Capacity	Total bytes*	Cylinders	Heads	Sectors	Max LBA
16 GB	16,013,942,784	16383	16	63	31,277,232
32 GB	32,017,047,552	16383	16	63	62,533,296
64 GB	64,023,257,088	16383	16	63	125,045,424
128 GB	128,035,676,160	16383	16	63	250,069,680

*Display of total bytes varies from file systems.

**Cylinders, heads or sectors are not applicable for these capacities. Only LBA addressing applies
LBA count addressed in the table above indicates total user storage capacity and will remain the same throughout the lifespan of the device. However, the total usable capacity of the CFast is most likely to be less than the total physical capacity because a small portion of the capacity is reserved for device maintenance usages.

4.2 Performance

Performance of CFast-M 2 HS product family is available as shown in Table 4-2.

Table 4-2: Performance table

Capacity	16 GB	32 GB	64 GB	128 GB
Performance				
Sustained Read (MB/s)	255	305	305	310
Sustained Write (MB/s)	41	70	155	240

Note: Performances results are measured by CrystalDiskMark under Windows 7 and may vary from host system configurations.

4.3 Environmental Specifications

Environmental specification of the CFast-M 2 HS follows the military standards, shown in Table 4-3.

Table 4-3 Environmental specification

Environment	Specification
Temperature	0°C to 70°C (Operating)
	-40°C to 100°C (Non-operating)
Vibration	Non-operating : Sine wave, 15(G), 10~2000(Hz), Operating : Random, 7.69(Grms), 20~2000(Hz)
Shock	Non-operating: Acceleration, 1,500 G, 0.5 ms Operating: Peak acceleration, 50 G, 11 ms

Note: this Environmental Specification table indicates the conditions for testing the device. Real world usages may affect the results.

4.4 Mean Time Between Failures (MTBF)

Mean Time Between Failures (MTBF) is predicted based on reliability data for the individual components in CFast-M 2 HS. Serving as statistical reference, the prediction result for CFast-M is more than 1,000,000 hours.

Notes about the MTBF:

The MTBF is predicated and calculated based on “Telcordia Technologies Special Report, SR-332, Issue 2” method.

4.5 Certification and Compliance

CFast-M 2 HS complies with the following standards

- CE
- FCC
- RoHS
- MIL-STD

4.6 Endurance

Terabytes Written (TBW) is an endurance rating system that indicates the maximum number of terabytes written by the host to the drive. NAND flash has a limit on how many P/E cycles it can withstand before its data retention becomes unreliable. Thus, key factors, such as flash configurations, wear leveling, Write Amplifications and the number of P/E cycles, can influence the lifespan of the drive.

The TBW of the device are listed in the following table.

Capacity	TBW (TB)
16 GB	26
32 GB	52
64 GB	104
128 GB	208

Notes:

- The measurement assumes the data written to the SSD for test is under a typical and constant rate.
- The measurement follows the standard metric: 1 TB (Terabyte) = 1000 GB.

5. Flash Management

5.1 Error Correction/Detection

Apacer implements a hardware ECC scheme, based on the BCH algorithm. It can detect and correct up to 40 bits error in 1K bytes.

5.2 Bad Block Management

Current production technology is unable to guarantee total reliability of NAND flash memory array. When a flash memory device leaves factory, it comes with a minimal number of initial bad blocks during production or out-of-factory as there is no currently known technology that produce flash chips free of bad blocks. In addition, bad blocks may develop during program/erase cycles. When host performs program/erase command on a block, bad block may appear in Status Register. Since bad blocks are inevitable, the solution is to keep them in control. Apacer flash devices are programmed with ECC, block mapping technique and S.M.A.R.T to reduce invalidity or error. Once bad blocks are detected, data in those blocks will be transferred to free blocks and error will be corrected by designated algorithms.

5.3 Wear Leveling

Flash memory devices differ from Hard Disk Drives (HDDs) in terms of how blocks are utilized. For HDDs, when a change is made to stored data, like erase or update, the controller mechanism on HDDs will perform overwrites on blocks. Unlike HDDs, flash blocks cannot be overwritten and each P/E cycle wears down the lifespan of blocks gradually. Repeatedly program/erase cycles performed on the same memory cells will eventually cause some blocks to age faster than others. This would bring flash storages to their end of service term sooner. Wear leveling is an important mechanism that level out the wearing of blocks so that the wearing-down of blocks can be almost evenly distributed. This will increase the lifespan of SSDs. Commonly used wear leveling types are Static and Dynamic.

5.4 Power Failure Management

Power Failure Management plays a crucial role when experiencing unstable power supply. Power disruption may occur when users are storing data into the SSD. In this urgent situation, the controller would run multiple write-to-flash cycles to store the metadata for later block rebuilding. This urgent operation requires about several milliseconds to get it done. At the next power up, the firmware will perform a status tracking to retrieve the mapping table and resume previously programmed NAND blocks to check if there is any incompleteness of transmission.

5.5 ATA Secure Erase

ATA Secure Erase is an ATA disk purging command currently embedded in most of the storage drives. Defined in ATA specifications, (ATA) Secure Erase is part of Security Feature Set that allows storage drives to erase all user data areas. The erase process usually runs on the firmware level as most of the ATA-based storage media currently in the market are built-in with this command. ATA Secure Erase can securely wipe out the user data in the drive and protects it from malicious attack.

5.6 TRIM

TRIM is a SATA command that helps improve the read/write performance and efficiency of solid-state drives (SSD). The command enables the host operating system to inform SSD controller which blocks contain invalid data, mostly because of the erase commands from host. The invalid will be discarded permanently and the SSD will retain more space for itself.

5.7 SATA Power Management Modes

By complying with SATA 6.0 Gb/s specifications, the SSD supports the following SATA power saving modes:

- ACTIVE: PHY ready, full power, Tx & Rx operational
- PARTIAL: Reduces power, resumes in under 10 μ s (microseconds)
- SLUMBER: Reduces power, resumes in under 10 ms (milliseconds)
- HIPM: Host-Initiated Power Management
- DIPM: Device-Initiated Power Management
- AUTO-SLUMBER: Automatic transition from partial to slumber.
- Device Sleep (DevSleep or DEVSLP): PHY powered down; power consumption \leq 5 mW; host assertion time \leq 10 ms; exit timeout from this state \leq 20 ms (unless specified otherwise in SATA Identify Device Log).

Note:

1. The behaviors of power management features would depend on host/device settings.
2. Device Sleep mode is optional depending on product ordering selections.

6. Software Interface

6.1 Command Set

Table 6-1: Command set

Code	Command	Code	Command
E5h	Check Power Mode	F6h	Security Disable Password
90h	Execute Diagnostics	F3h	Security Erase Prepare
E7h	Flush Cache	F4h	Security Erase Unit
ECh	Identify Device	F5h	Security Freeze Lock
E3h	Idle	F1h	Security Set Password
E1h	Idle Immediate	F2h	Security Unlock
91h	Initialize Device Parameters	7xh	Seek
C8h	Read DMA	EFh	Set Features
25h	Read DMA EXT	C6h	Set Multiple Mode
60h	Read FPDMA Queued	E6h	Sleep
47h	Read Log DMA EXT	B0h	S.M.A.R.T.
2Fh	Read Log EXT	E2h	Standby
C4h	Read Multiple	E0h	Standby Immediate
20 or 21h	Read Sector(s)	CAh	Write DMA
40 or 41h	Read Verify Sector(s)	35h	Write DMA EXT
10h	Recalibrate	61h	Write FPDMA Queued
57h	Write Log DMA EXT	3Fh	Write Log EXT
C5h	Write Multiple	30h or 31h	Write Sector(s)

6.2 S.M.A.R.T.

S.M.A.R.T. is an abbreviation for Self-Monitoring, Analysis and Reporting Technology, a self-monitoring system that provides indicators of drive health as well as potential disk problems. It serves as a warning for users from unscheduled downtime by monitoring and displaying critical drive information. Ideally, this should allow taking proactive actions to prevent drive failure and make use of S.M.A.R.T. information for future product development reference.

Apacer devices use the standard SMART command B0h to read data out from the drive to activate our S.M.A.R.T. feature that complies with the ATA/ATAPI specifications. S.M.A.R.T. Attribute IDs shall include initial bad block count, total later bad block count, maximum erase count, average erase count, power on hours and power cycle. When the S.M.A.R.T. Utility running on the host, it analyzes and reports the disk status to the host before the device reaches in critical condition.

Note: attribute IDs may vary from product models due to various solution design and supporting capabilities.

CFast-M 2 HS

AP-CFAxxxxACAD-XTM

Apacer memory products come with S.M.A.R.T. commands and subcommands for users to obtain information of drive status and to predict potential drive failures. Users can take advantage of the following commands/subcommands to monitor the health of the drive.

Code	SMART Subcommand
D0h	READ DATA
D1h	READ ATTRIBUTE THRESHOLDS
D2h	Enable/Disable Attribute Autosave
D4h	Execute Off-line Immediate
D5h	Read Log (optional)
D6h	Write Log (optional)
D8h	Enable Operations
D9h	Disable operations
DAh	Return Status

General SMART attribute structure

Byte	Description
0	ID (Hex)
1 – 2	Status flag
3	Value
4	Worst
5*-11	Raw Data

*Byte 5: LSB

SMART attribute ID list

ID (Hex)	Attribute Name
9 (0x09)	Power-on hours
12 (0x0C)	Power cycle count
163 (0xA3)	Max. erase count
164 (0xA4)	Avg. erase count
166 (0xA6)	Total later bad block count
167 (0xA7)	SSD Protect Mode (vendor specific)
168 (0xA8)	SATA PHY Error Count
175 (0xAF)	Bad Cluster Table Count
192 (0xC0)	Unexpected Power Loss Count
194 (0xC2)	Temperature
241 (0xF1)	Total sectors of write

7. Electrical Specification

7.1 Operating Voltage

Table 7-1 lists operating voltage of CFast-M 2 HS.

Table 7-1: Operating voltage

Parameter	Symbol	Min	Typ	Max	Units
Power Supply	Vcc	3.135	3.3	3.465	V

7.2 Power Consumption

Table 7-2 Power consumption (typical)

Mode \ Capacity	16 GB	32 GB	64 GB	128 GB
Active (mA)	260	280	370	525
Idle (mA)	140	140	140	140

Note: Power consumption may vary from flash configurations and/or platform settings.

8. Physical Characteristics

8.1 Dimensions

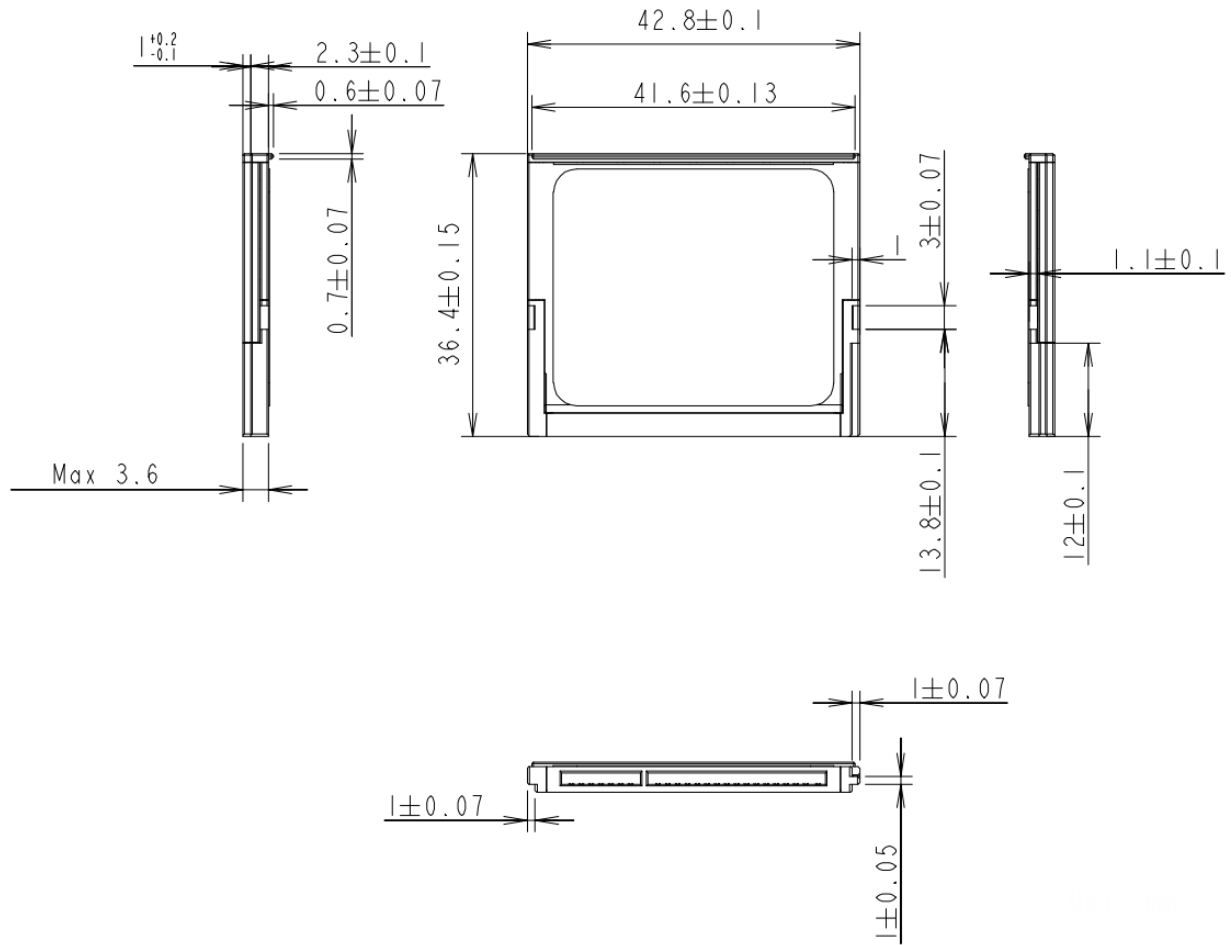

Unit: mm

FIGURE 8-1: Physical dimension

9. Product Ordering Information

9.1 Product Code Designations

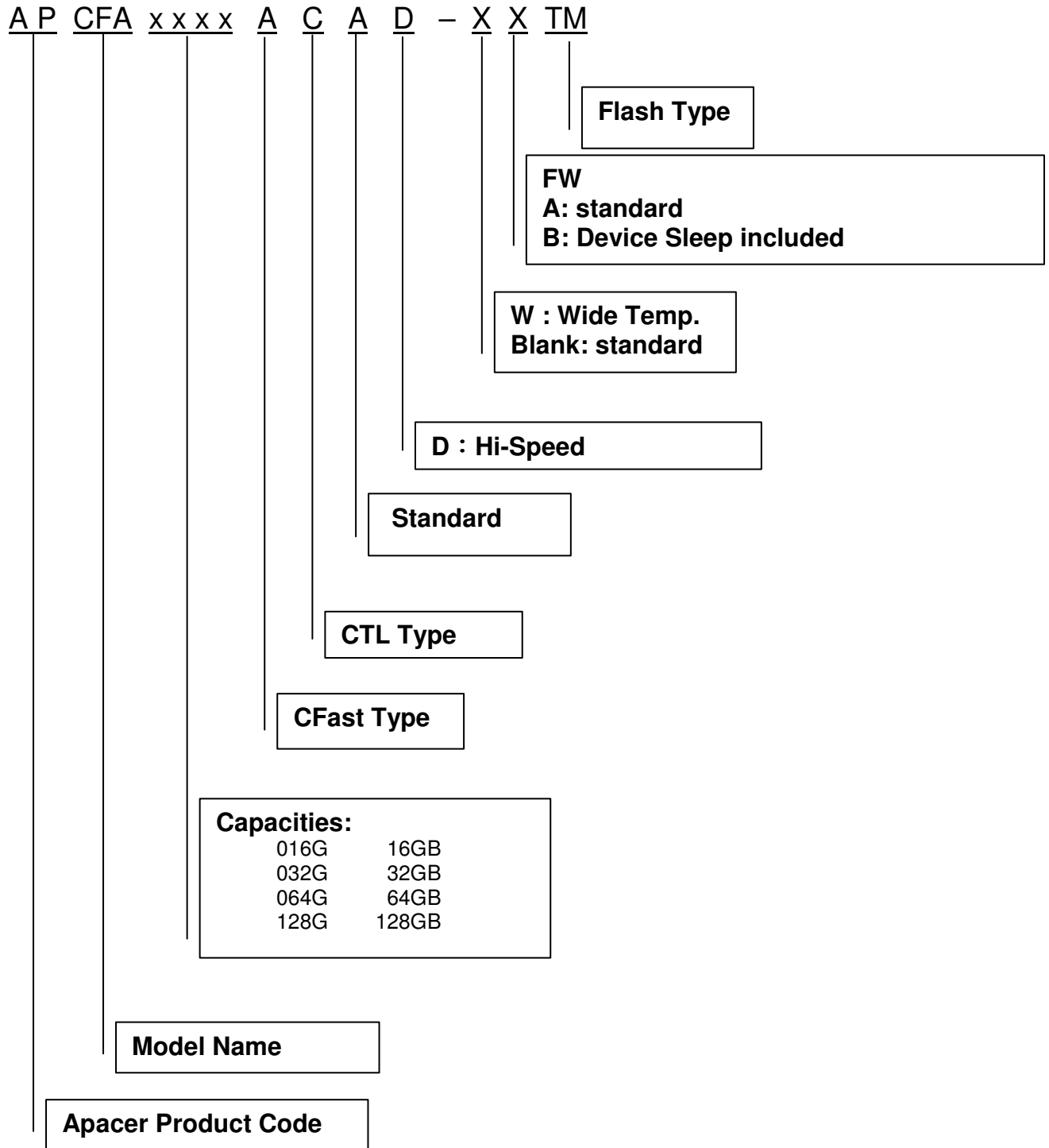

9.2 Valid Combinations

9.2.1 Standard Temperature

7.2.1.1 (STD)

Capacity	AP/N
16GB	APCFA016GACAD-ATM
32GB	APCFA032GACAD-ATM
64GB	APCFA064GACAD-ATM
128GB	APCFA128GACAD-ATM

7.2.1.2 (DEVSLP)

Capacity	AP/N
16GB	APCFA016GACAD-BTM
32GB	APCFA032GACAD-BTM
64GB	APCFA064GACAD-BTM
128GB	APCFA128GACAD-BTM

Note: Please consult with Apacer sales representatives for availabilities.

Revision History

Revision	Date	Description	Remark
0.1	11/19/2013	Preliminary	
1.0	11/26/2013	Official release	
1.1	02/14/2014	Added Endurance (TBW) section	

Global Presence

Taiwan (Headquarters)	Apacer Technology Inc. Apacer Technology Inc. 1F., No.32, Zhongcheng Rd., Tucheng Dist., New Taipei City 236, Taiwan R.O.C. Tel: 886-2-2267-8000 Fax: 886-2-2267-2261 amtsales@apacer.com
U.S.A.	Apacer Memory America, Inc. 386 Fairview Way, Suite102, Milpitas, CA 95035 Tel: 1-408-518-8699 Fax: 1-408-935-9611 sa@apacerus.com
Japan	Apacer Technology Corp. 5F, Matsura Bldg., Shiba, Minato-Ku Tokyo, 105-0014, Japan Tel: 81-3-5419-2668 Fax: 81-3-5419-0018 jpservices@apacer.com
Europe	Apacer Technology B.V. Science Park Eindhoven 5051 5692 EB Son, The Netherlands Tel: 31-40-267-0000 Fax: 31-40-267-0000#6199 sales@apacer.nl
China	Apacer Electronic (Shanghai) Co., Ltd 1301, No.251, Xiaomuqiao Road, Shanghai, 200032, China Tel: 86-21-5529-0222 Fax: 86-21-5206-6939 sales@apacer.com.cn
India	Apacer Technologies Pvt Ltd, # 535, 1st Floor, 8th cross, JP Nagar 3rd Phase, Bangalore – 560078, India Tel: 91-80-4152-9061 sales_india@apacer.com