



FCC SDoC Test Report

Product : mSATA SSD
Model Name : SV240-300
Series Model : SX240-300 (X=A~Z)
Applicant : APACER TECHNOLOGY INC
1F., No.32, Zhongcheng Rd., Tucheng Dist.,
New Taipei City 236, Taiwan
Manufacturer : APACER TECHNOLOGY INC
1F., No.32, Zhongcheng Rd., Tucheng Dist.,
New Taipei City 236, Taiwan
Standard : 47 CFR FCC Rules and Regulations Part 15
Subpart B, Class B Digital Device

The product was received on Mar. 31, 2020, and testing was started from Mar. 31, 2020 and completed on Apr. 09, 2020. We, SPORTON INTERNATIONAL INC. EMC & Wireless Communications Laboratory, would like to declare that the tested sample has been evaluated in accordance with the procedures given in ANSI C63.4-2014 and shown compliance with the applicable technical standards.

The report must not be used by the client to claim product certification, approval, or endorsement by TAF or any agency of government.

The test results in this report apply exclusively to the tested model / sample. Without written approval of SPORTON INTERNATIONAL INC. EMC & Wireless Communications Laboratory, the test report shall not be reproduced except in full.

Approved by: William Li

SPORTON INTERNATIONAL INC. EMC & Wireless Communications Laboratory
No. 52, Huaya 1st Rd., Guishan Dist., Taoyuan City, Taiwan (R.O.C.)



Table of Contents

History of this test report.....3

Summary of Test Result.....4

1. General Description of Equipment under Test.....5

 1.1. Basic Description of Equipment under Test 5

 1.2. Feature of Equipment under Test..... 5

 1.3. Modification of EUT..... 5

 1.4. Table for Multiple Listing 5

2. Test Configuration of Equipment under Test6

 2.1. Details of EUT Test Modes..... 6

 2.2. Description of Test System..... 6

 2.3. Connection Diagram of Test System 7

 2.4. Test Manner 9

3. General Information of Test.....10

 3.1. Test Facilities 10

 3.2. Test Standards..... 10

 3.3. Test Voltage/Frequencies 10

 3.4. Test Distance and Frequency Range Investigated 10

 3.5. Operating Condition 10

 3.6. Labelling requirements 11

 3.7. User Information..... 11

4. Conducted Emissions Measurement12

 4.1. Limit 12

 4.2. Test Procedures..... 12

 4.3. Measurement Results Calculation 12

 4.4. Typical Test Setup Layout 13

 4.5. Test Result..... 14

5. Radiated Emissions Measurement16

 5.1. Radiated Emission below 1GHz 16

 5.2. Radiated Emission above 1GHz..... 22

6. Uncertainty of Test Site26

 6.1. Emission Test Measurement Uncertainty 26

7. List of Measuring Equipment Used27

Appendix A. Test Photos

Photographs of EUT v01



Summary of Test Result

Report Clause	Ref Std. Clause	Test Items	Result (PASS/FAIL)	Remark
4	15.107	Conducted Emissions of Powerline	PASS	Under limit 14.97 dB at 29.43 MHz
5.1	15.109	Radiated Emissions below 1GHz	PASS	Under limit 5.88 dB at 66.330 MHz
5.2	15.109	Radiated Emissions above 1GHz	PASS	Under limit 24.40 dB at 1.95 GHz

Declaration of Conformity:
The test results with all measurement uncertainty excluded are presented in accordance with the regulation limits or requirements declared by manufacturers.
Comments and Explanations:
None

Reviewed by: Mark Ma

Report Producer: Michelle Tsai



1. General Description of Equipment under Test

1.1. Basic Description of Equipment under Test

Product : mSATA SSD
Model Name : SV240-300
Series Model : SX240-300 (X=A~Z)
Power Supply Type : From Host System
The maximum operating frequency : 350MHz

1.2. Feature of Equipment under Test

For a more detailed features description, please refer to the manufacturer's specifications or the User's Manual.

1.3. Modification of EUT

No modifications to the EUT were made.

1.4. Table for Multiple Listing

Series Model	Description
SX240-300 (X=A~Z)	The difference of models is in sales marketing.

Note: The information from manufacturer.



2. Test Configuration of Equipment under Test

2.1. Details of EUT Test Modes

From the above models, Model: SV240-300 was selected as representative model for the test and its data was recorded in this report. The equipment under test was performed the following test modes:

Test Items	Description of test modes
Conducted Emission	Mode 1. DATA COPY
Radiated Emissions <below 1GHz>	Mode 1. DATA COPY
Radiated Emissions <above 1GHz>	Mode 1. DATA COPY

2.2. Description of Test System

Conducted emission and radiated emission below 1GHz

No.	Peripheral	Manufacturer	Model Number	FCC ID	Remarks
For Local					
A	Personal Computer	ASUS	M32CD	DoC	-
B	LCD Monitor	ASUS	VS197DE	DoC	-
C	Keyboard	ASUS	AW211	DoC	-
D	Mouse	ASUS	MOBTUO	DoC	-
E	Printer	Fuji Xerox	Phaser 3121	DoC	-
F	iPod Nano	Apple	A1137	DoC	-

Radiated emission above 1GHz

No.	Peripheral	Manufacturer	Model Number	FCC ID	Remarks
For Local					
A	Personal Computer	ASUS	M32CD	DoC	-
B	LCD Monitor	DELL	U2410f	DoC	-
C	Keyboard	Microsoft	1366	DoC	-
D	Mouse	Microsoft	1113	DoC	-
E	Printer	EPSON	C61	N/A	-
F	iPod Nano	Apple	A1137	DoC	-

2.3. Connection Diagram of Test System

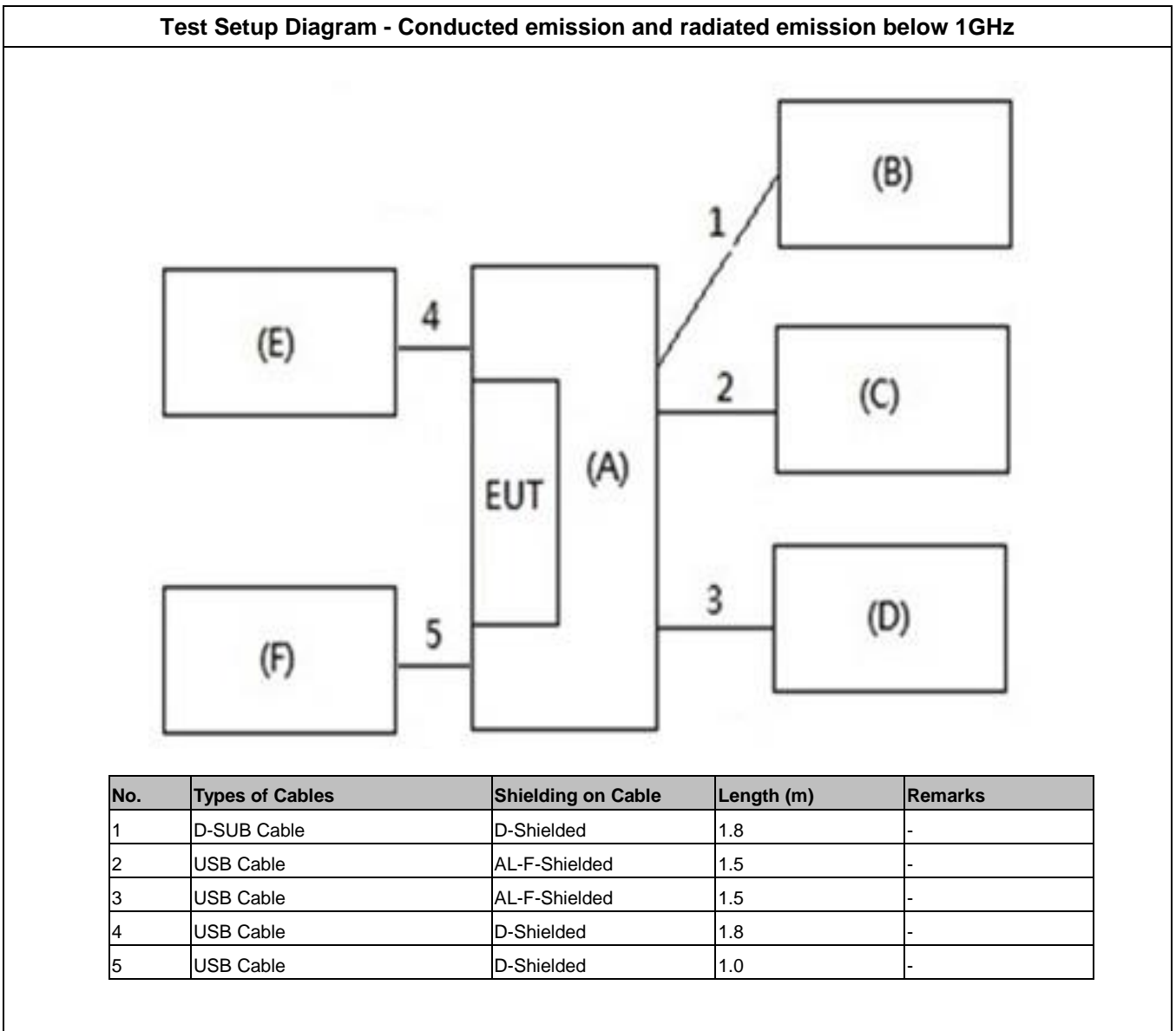

Test Setup Diagram - Radiated emission above 1GHz

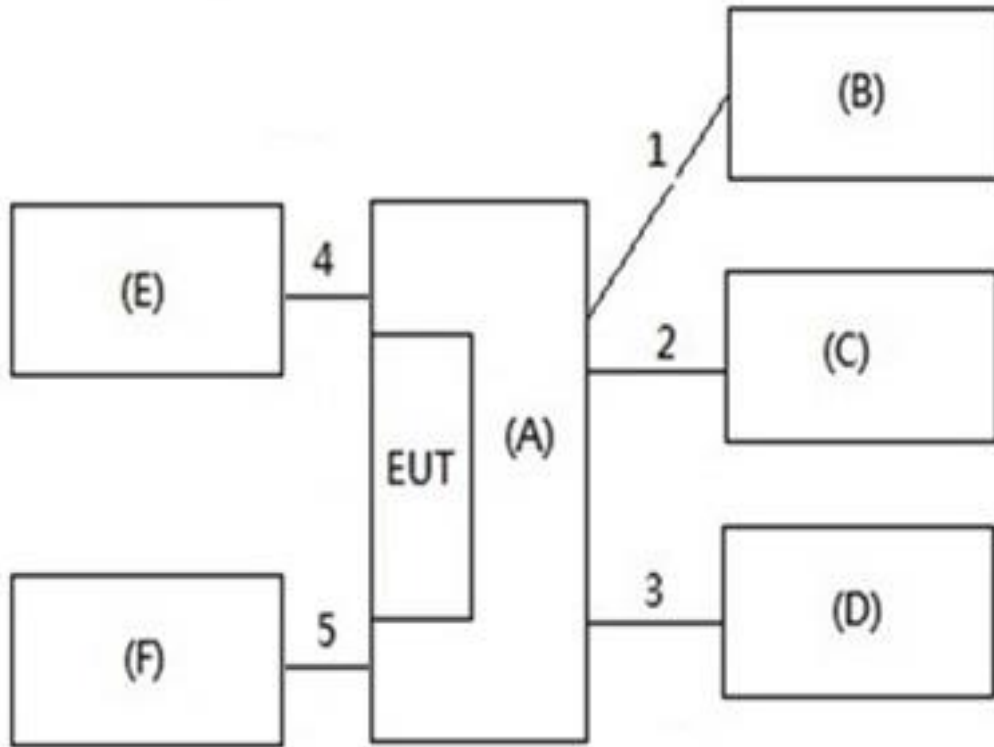

No.	Types of Cables	Shielding on Cable	Length (m)	Remarks
1	D-SUB Cable	D-Shielded	1.8	-
2	USB Cable	AL-F-Shielded	2.0	-
3	USB Cable	AL-F-Shielded	1.8	-
4	USB Cable	D-Shielded	1.8	-
5	USB Cable	D-Shielded	1.0	-



2.4. Test Manner

An executive program, "BurnInTest" under WIN 10 was used as the test software. The program was executed as follows:

- Turn on the power of all equipment.
- The PC reads the test program from the hard disk drive and runs it.
- The PC sends "H" pattern to the monitor, and the monitor displays "H" patterns on the screen.
- The PC executed "BurnInTest" to read and write data from iPod Nano and EUT.
- The PC open "Word" to sends "H" messages to the printer, then the printer prints them on the paper.



3. General Information of Test

3.1. Test Facilities

Test Site : SPORTON INTERNATIONAL INC.	
<input checked="" type="checkbox"/> HUA YA	ADD: No. 52, Huaya 1st Rd., Guishan Dist., Taoyuan City, Taiwan (R.O.C.) TEL: 886-3-327-3456 FAX: 886-3-318-0055 FCC Designation Number: TW1093
<input checked="" type="checkbox"/> DONG HU	ADD: No. 3, Ln. 238, Kangle St., Neihu Dist., Taipei City, Taiwan (R.O.C.) TEL: 886-2-2631-5551 FAX: 886-2-2631-9740 FCC Designation Number: TW1094
<input type="checkbox"/> LIN KOU	ADD: No. 30-2, Dingfu Vil., Linkou Dist., New Taipei City, Taiwan (R.O.C.) TEL: 886-2-2601-1640 FAX: 886-2-2601-1695 FCC Designation Number: TW1095

Test Items	Test Site No.	Test Engineer	Test Environment		Test Date	Remark
			temp °C	hum %		
Conducted Emissions of Powerline	CO01-NH	Willy Lee	23.4~23.7	52.3~52.5	06/Apr/2020	-
Radiated Emissions below 1GHz	OS03-NH	Louis Lin	20.1~20.2	55.2~55.4	06/Apr/2020	-
Radiated Emissions above 1GHz	03CH04-HY	Alan Chen	23.6~23.7	61~62	09/Apr/2020	-

3.2. Test Standards

Test items	Test Standards and Test Procedures
Radiated and Conducted Emissions	ANSI C63.4:2014 with FCC Method 47 CFR Part 15, Subpart B, Class B Digital Device, CISPR PUB. 22

3.3. Test Voltage/Frequencies

Power Supply Type	Voltage/Frequencies
AC Power Supply	120V / 60Hz

3.4. Test Distance and Frequency Range Investigated

Test Items	Frequency Range	Remark
Powerline Conducted Emissions	150 kHz to 30 MHz	-
Radiated Emissions (below 1GHz)	30 MHz to 1,000 MHz	Measurement distance is 10 m.
Radiated Emissions (above 1GHz)	1,000 MHz to 2,000 MHz	Measurement distance is 3 m.

3.5. Operating Condition

- Full system.



3.6. Labelling requirements

The devices shall bear the following statement in a conspicuous location on the device:

This device complies with part 15 of the FCC Rules. Operation is subject to the following two conditions: (1) This device may not cause harmful interference, and (2) this device must accept any interference received, including interference that may cause undesired operation.

3.7. User Information

The users manual or instruction manual for an intentional or unintentional radiator shall caution the user that changes or modifications not expressly approved by the party responsible for compliance could void the user's authority to operate the equipment.

For a Class B digital device or peripheral, the instructions furnished the user shall include the following or similar statement, placed in a prominent location in the text of the manual:

This equipment has been tested and found to comply with the limits for a Class B digital device, pursuant to part 15 of the FCC Rules. These limits are designed to provide reasonable protection against harmful interference in a residential installation.

This equipment generates, uses and can radiate radio frequency energy and, if not installed and used in accordance with the instructions, may cause harmful interference to radio communications. However, there is no guarantee that interference will not occur in a particular installation.

If this equipment does cause harmful interference to radio or television reception, which can be determined by turning the equipment off and on, the user is encouraged to try to correct the interference by one or more of the following measures:

- Reorient or relocate the receiving antenna.
- Increase the separation between the equipment and receiver.
- Connect the equipment into an outlet on a circuit different from that to which the receiver is connected.
- Consult the dealer or an experienced radio/TV technician for help.



4. Conducted Emissions Measurement

Conducted Emissions were measured according to the methods defined in ANSI C63.4-2014 Section 7. The EUT is which satisfies the Class B disturbance limits.

4.1. Limit

Limits for conducted disturbance at the mains ports of class B			
Frequency range MHz	Coupling device	Detector type / bandwidth	Class B limits dB(µV)
0,15 – 0,5	AMN	Quasi-peak / 9 kHz	66 - 56
0,5 – 5			56
5 – 30			60
0,15 – 0,5	AMN	Average / 9 kHz	56 - 46
0,5 – 5			46
5 – 30			50

Note 1: The lower limit shall apply at the transition frequencies.
Note 2: The limit decreases linearly with the logarithm of the frequency in the range 0.15 MHz to 0.50 MHz.

4.2. Test Procedures

- a). The EUT was warmed up for 15 minutes before testing started.
- b). The EUT was placed on a desk 0.8 meter height from the metal ground plane and 0.4 meter from the conducting wall of the shielding room and it was kept at least 0.8 meter from any other grounded conducting surface.
- c). Connect EUT to the power mains through a line impedance stabilization network (LISN).
- d). All the support units are connect to the other LISN.
- e). The LISN provides 50 ohm, coupling impedance for the measuring instrument.
- f). The FCC states that a 50 ohm, 50 microhenry LISN should be used.
- g). Both sides of AC line were checked for maximum conducted interference.
- h). The frequency range from 150 kHz to 30 MHz was searched.
- i). Set the test-receiver system to Peak Detect Function and Specified Bandwidth with Maximum Hold Mode.
- j). All emissions not reported here are more than 10 dB below the prescribed limit.

4.3. Measurement Results Calculation

The measurand Level is calculated using:
Corrected Reading (dBµV) = LISN Factor + Cable Loss + Read Level
For example at 0.3 MHz if the LISN Factor is 10.48 dB, the cable loss is 0.10 dB, the measured voltage is 36.39 dBµV, the signal strength would be calculated:
Corrected Reading (dBµV) = 10.48 dB + 0.10 dB + 36.39 dBµV = 46.97 dBµV

4.4. Typical Test Setup Layout

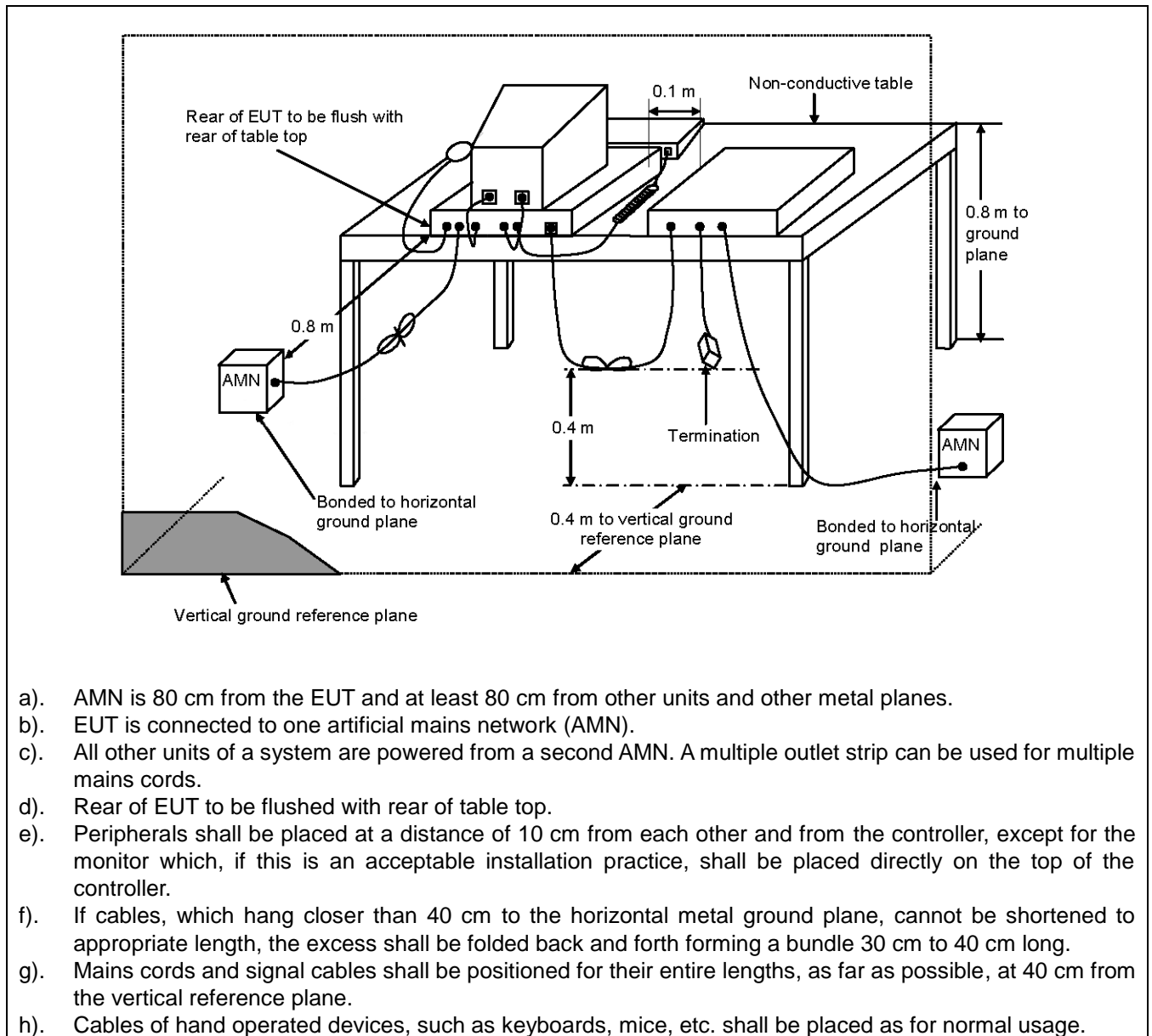



4.5. Test Result

Test Mode	Mode 1		
Test Frequency	0.15 MHz ~ 30 MHz	Test Voltage	AC 120V / 60Hz
<p>■ The test was passed at the minimum margin that marked by the frame in the following data</p>			

Line

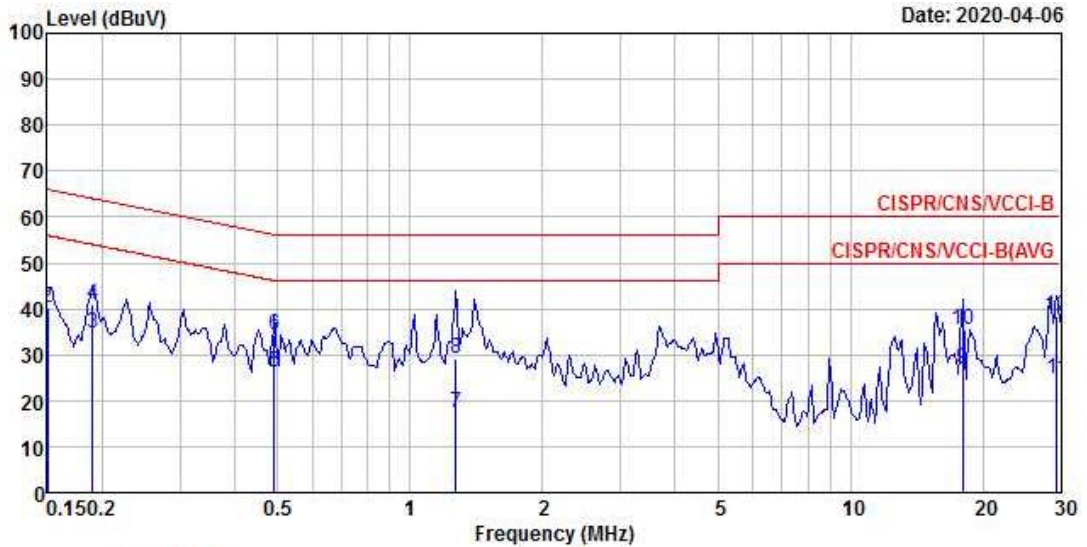

	Freq	Level	Over Limit	Limit Line	Read Level	LISN Factor	Cable Loss	Remark
	MHz	dBuV	dB	dBuV	dBuV	dB	dB	
1	0.15	33.64	-22.36	56.00	23.25	10.29	0.10	Average
2	0.15	40.30	-25.70	66.00	29.91	10.29	0.10	QP
3 @	0.19	34.69	-19.33	54.02	24.29	10.30	0.10	Average
4	0.19	40.95	-23.07	64.02	30.55	10.30	0.10	QP
5	0.49	26.06	-20.08	46.14	15.64	10.30	0.12	Average
6	0.49	34.19	-21.95	56.14	23.77	10.30	0.12	QP
7	1.27	17.34	-28.66	46.00	6.82	10.32	0.20	Average
8	1.27	28.98	-27.02	56.00	18.46	10.32	0.20	QP
9	17.97	27.08	-22.92	50.00	16.11	10.61	0.36	Average
10	17.97	35.58	-24.42	60.00	24.61	10.61	0.36	QP
11	29.43	24.84	-25.16	50.00	13.61	10.83	0.40	Average
12	29.43	38.48	-21.52	60.00	27.25	10.83	0.40	QP



Neutral

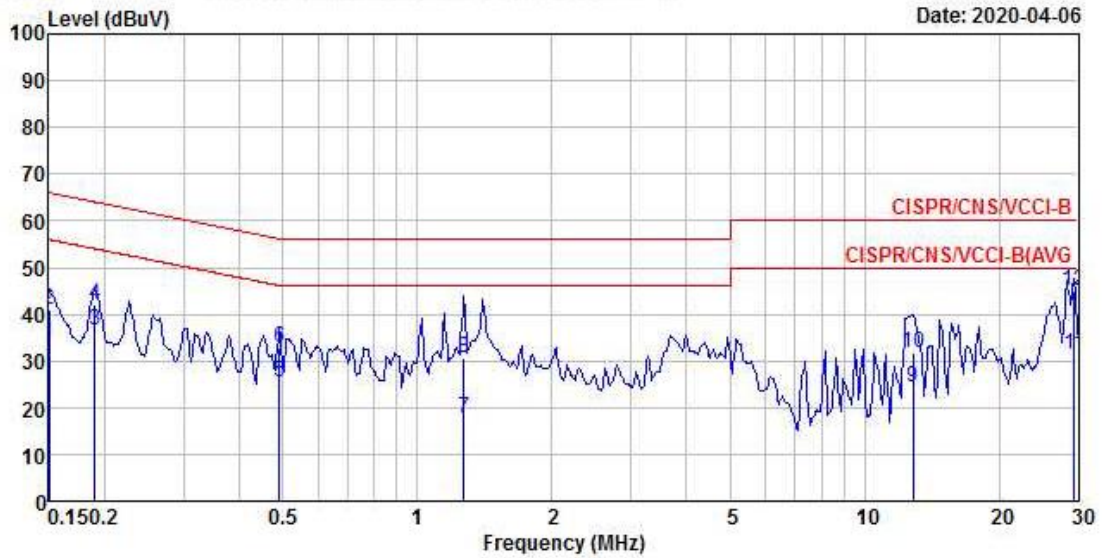

	Freq	Level	Over Limit	Limit Line	Read Level	LISN Factor	Cable Loss	Remark
	MHz	dBuV	dB	dBuV	dBuV	dB	dB	
1	0.15	34.50	-21.50	56.00	24.11	10.29	0.10	Average
2	0.15	40.98	-25.02	66.00	30.59	10.29	0.10	QP
3	0.19	36.66	-17.36	54.02	26.26	10.30	0.10	Average
4	0.19	41.95	-22.07	64.02	31.55	10.30	0.10	QP
5	0.49	25.43	-20.71	46.14	15.00	10.31	0.12	Average
6	0.49	32.93	-23.21	56.14	22.50	10.31	0.12	QP
7	1.27	17.85	-28.15	46.00	7.32	10.33	0.20	Average
8	1.27	30.60	-25.40	56.00	20.07	10.33	0.20	QP
9	12.85	24.45	-25.55	50.00	13.60	10.55	0.30	Average
10	12.85	31.80	-28.20	60.00	20.95	10.55	0.30	QP
11	29.43	31.44	-18.56	50.00	20.11	10.93	0.40	Average
12 @	29.43	45.03	-14.97	60.00	33.70	10.93	0.40	QP



5. Radiated Emissions Measurement

Radiated Emissions were measured according to the methods defined in ANSI C63.4-2014 Section 8. The EUT is which satisfies the Class B disturbance limits.

5.1. Radiated Emission below 1GHz

5.1.1.Limit

radiated emissions at frequencies up to 1 GHz for Class B equipment			
Frequency range MHz	Measurement		Class B limits
	Distance (m)	Detector type / bandwidth	dB(µV/m)
30 – 230	10	Quasi Peak / 120 kHz	30
230 – 1000			37

5.1.2.Test Procedures

- a). The EUT was placed on a rotatable table top 0.8 meter above ground.
- b). The EUT was set 10 meters from the interference-receiving antenna which was mounted on the top of a variable height antenna tower.
- c). The table was rotated 360 degrees to determine the position of the highest radiation.
- d). The antenna is a half wave dipole and its height is varied between one meter and four meters above ground to find the maximum value of the field strength both horizontal polarization and vertical polarization of the antenna are set to make the measurement.
- e). For each suspected emission the EUT was arranged to its worst case and then tune the antenna tower (from 1 M to 4 M) and turn table (from 0 degree to 360 degrees) to find the maximum reading.
- f). Set the test-receiver system to Peak Detect Function and specified bandwidth with Maximum Hold Mode.
- g). If the emission level of the EUT in peak mode was 3 dB lower than the limit specified, then testing will be stopped and peak values of EUT will be reported, otherwise, the emissions which do not have 3 dB margin will be repeated one by one using the quasi-peak method and reported.
- h). The FCC Part 15.109(g) permit parties seeking to authorize a digital device to choose to demonstrate that the device complies with either the Part 15 standards or the international standards found in Publication 22 of the International Special Committee on Radio Interference (CISPR).

5.1.3.Measurement Results Calculation

The measurand Level is calculated using:
Corrected Reading (dBµV/m) = Antenna Factor + Cable Loss + Read Level – Preamp Factor
For example at 125 MHz if the Antenna Factor is 17.24 dB/m, the cable loss is 1.20 dB, the measured voltage is 35.80 dBµV and the Preamp Factor is 27.18 dB, the signal strength would be calculated:
Corrected Reading (dBµV/m) = 17.24 dB/m + 1.20 dB + 35.80 dBµV - 27.18 dB = 27.06 dBµV/m
Note: If a hybrid antenna is used, the antenna factor shell be the sum of the Antenna Factor + Attenuator Factor.

5.1.4. Typical Test Setup Layout

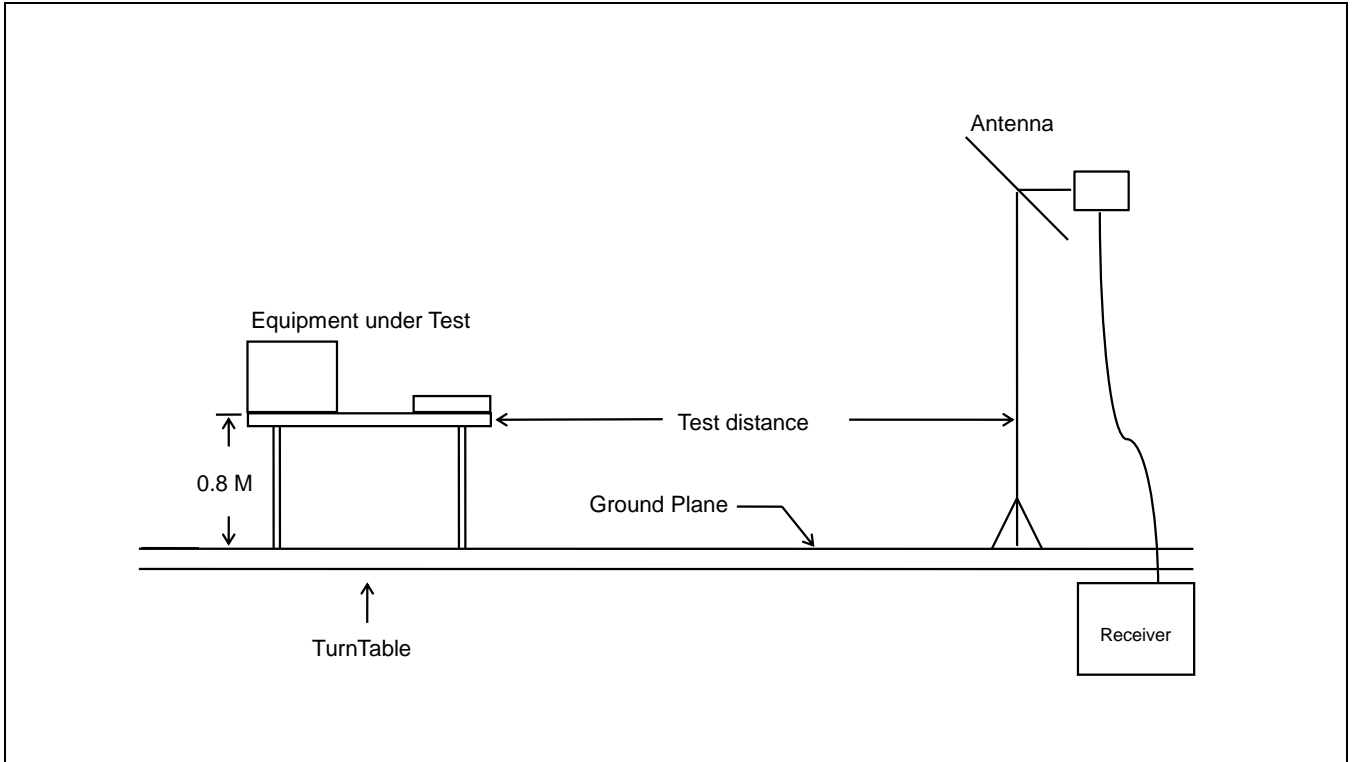



5.1.5. Test Result

Test mode	Mode 1		
Test frequency	30 MHz ~ 1000 MHz	Test Voltage	AC 120V / 60Hz
<p>■ The test was passed at the minimum margin that marked by the frame in the following data</p>			

Vertical

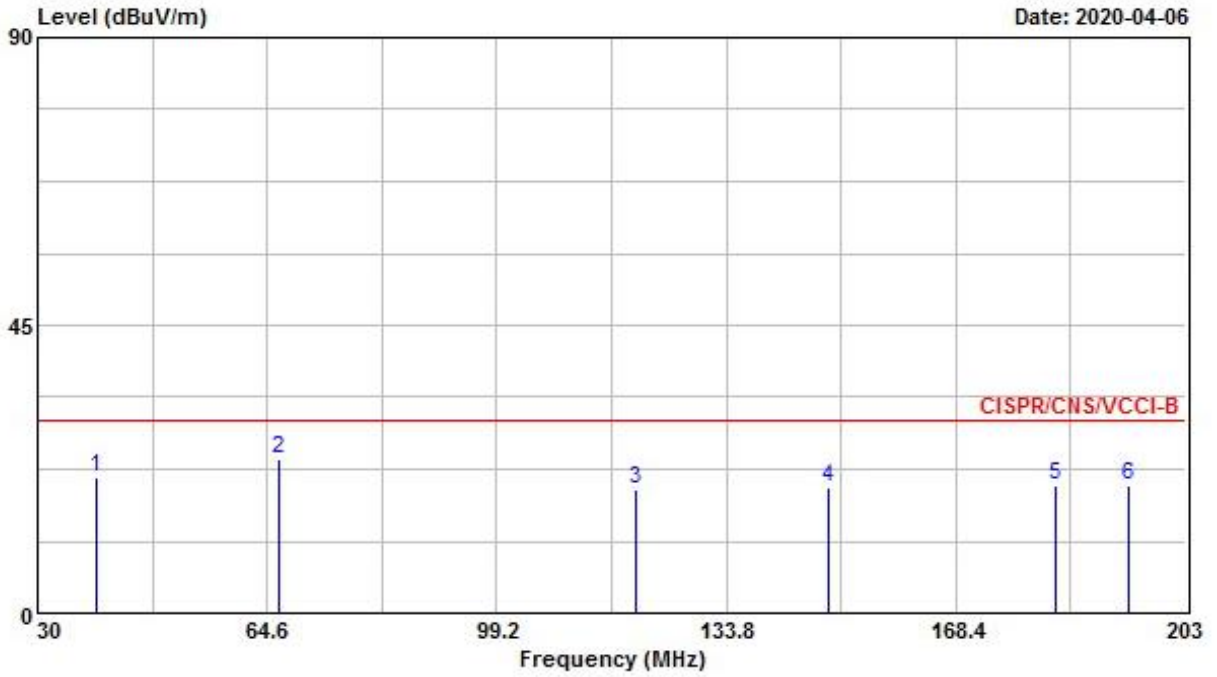

	Freq	Level	Over	Limit	ReadAntenna	Cable	Preamp	Remark	Ant	Table
	MHz	dBuV/m	dB	dBuV/m	dBuV	dB/m	dB		cm	deg
1	38.820	21.21	-8.79	30.00	30.37	18.20	1.06	28.42 Peak	---	---
2	66.330	24.12	-5.88	30.00	39.50	11.61	1.39	28.38 Peak	100	185
3	120.130	19.18	-10.82	30.00	27.62	17.90	1.89	28.23 Peak	---	---
4	149.200	19.54	-10.46	30.00	29.63	15.88	2.15	28.12 Peak	---	---
5	183.450	19.83	-10.17	30.00	30.82	14.52	2.48	27.99 Peak	---	---
6	194.520	20.08	-9.92	30.00	30.90	14.53	2.60	27.95 Peak	---	---



Vertical

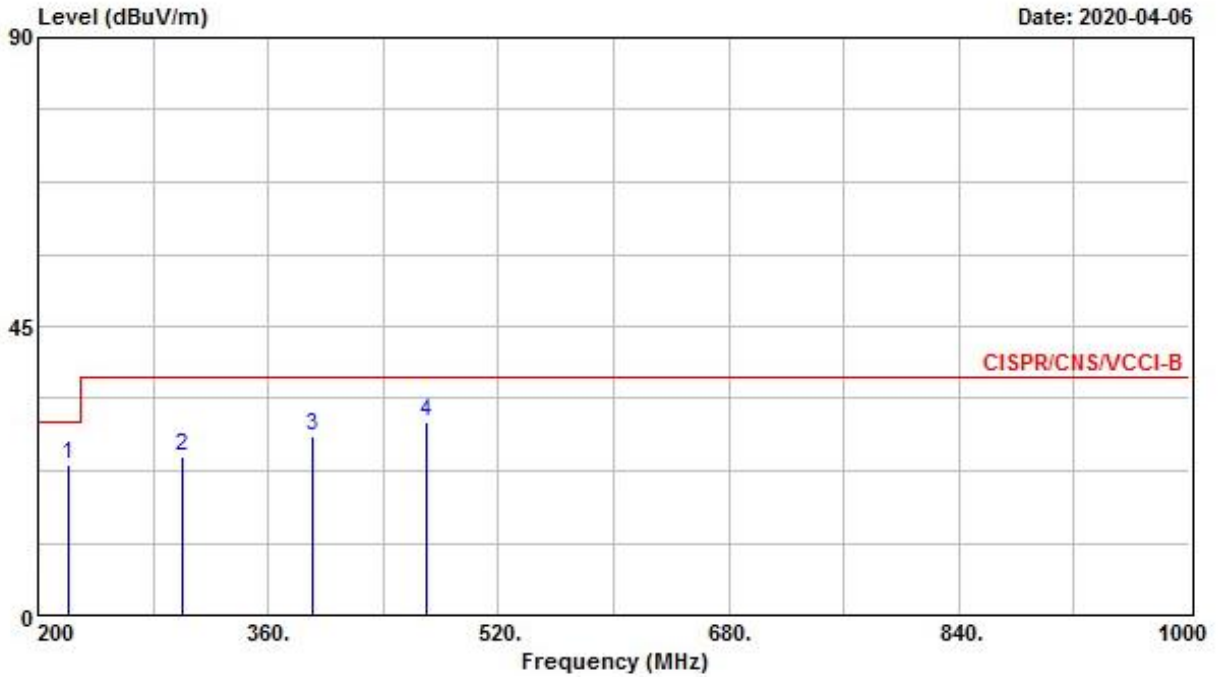

	Freq	Level	Over Limit	Limit Line	ReadAntenna Level	Antenna Factor	Cable Loss	Preamp Factor	Remark	Ant Pos	Table Pos
	MHz	dBuV/m	dB	dBuV/m	dBuV	dB/m	dB	dB		cm	deg
1	221.600	23.58	-6.42	30.00	33.62	15.05	2.81	27.90	Peak	---	---
2	300.000	24.82	-12.18	37.00	30.69	18.67	3.26	27.80	Peak	---	---
3	391.200	27.99	-9.01	37.00	31.87	20.80	3.77	28.45	Peak	---	---
4	469.600	30.21	-6.79	37.00	32.46	22.36	4.27	28.88	Peak	---	---



Horizontal

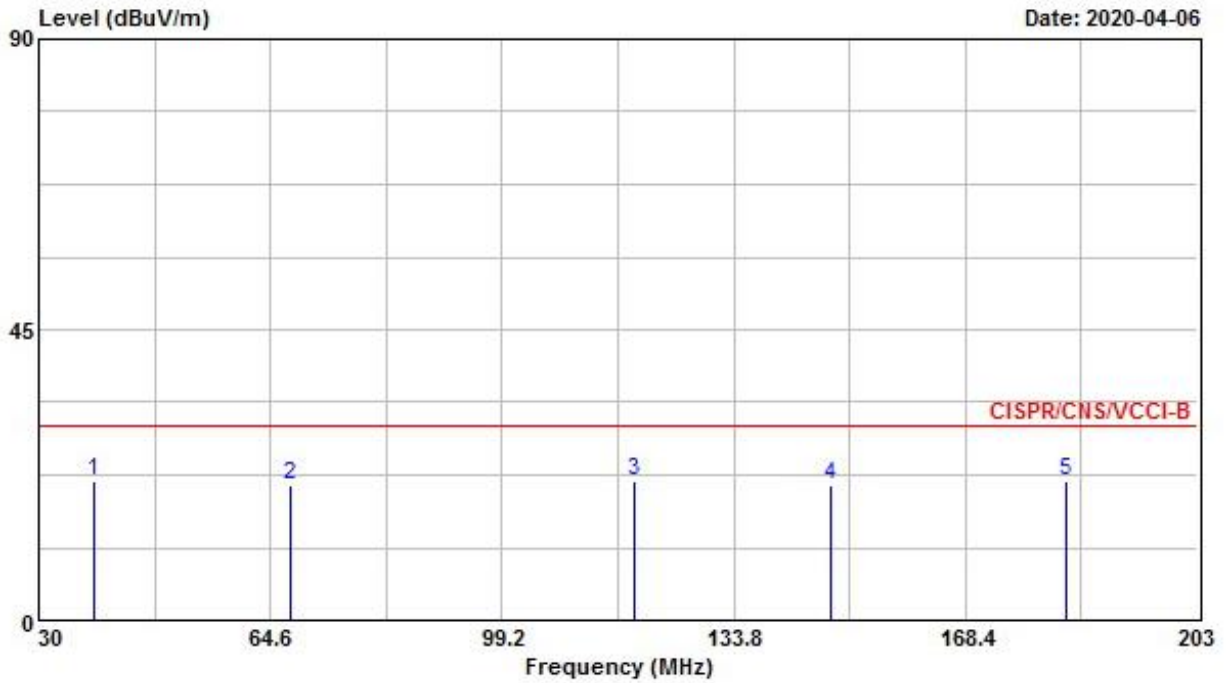

	Freq	Level	Over Limit	Limit Line	ReadAntenna Level	Antenna Factor	Cable Loss	Preamp Factor	Remark	Ant Pos	Table Pos
	MHz	dBuV/m	dB	dBuV/m	dBuV	dB/m	dB	dB		cm	deg
1	38.300	21.43	-8.57	30.00	30.59	18.20	1.06	28.42	Peak	---	---
2	67.540	20.76	-9.24	30.00	36.09	11.61	1.43	28.37	Peak	---	---
3	118.920	21.60	-8.40	30.00	30.12	17.84	1.88	28.24	Peak	---	---
4	148.330	20.97	-9.03	30.00	31.02	15.94	2.14	28.13	Peak	---	---
5	183.450	21.45	-8.55	30.00	32.44	14.52	2.48	27.99	Peak	---	---



Horizontal

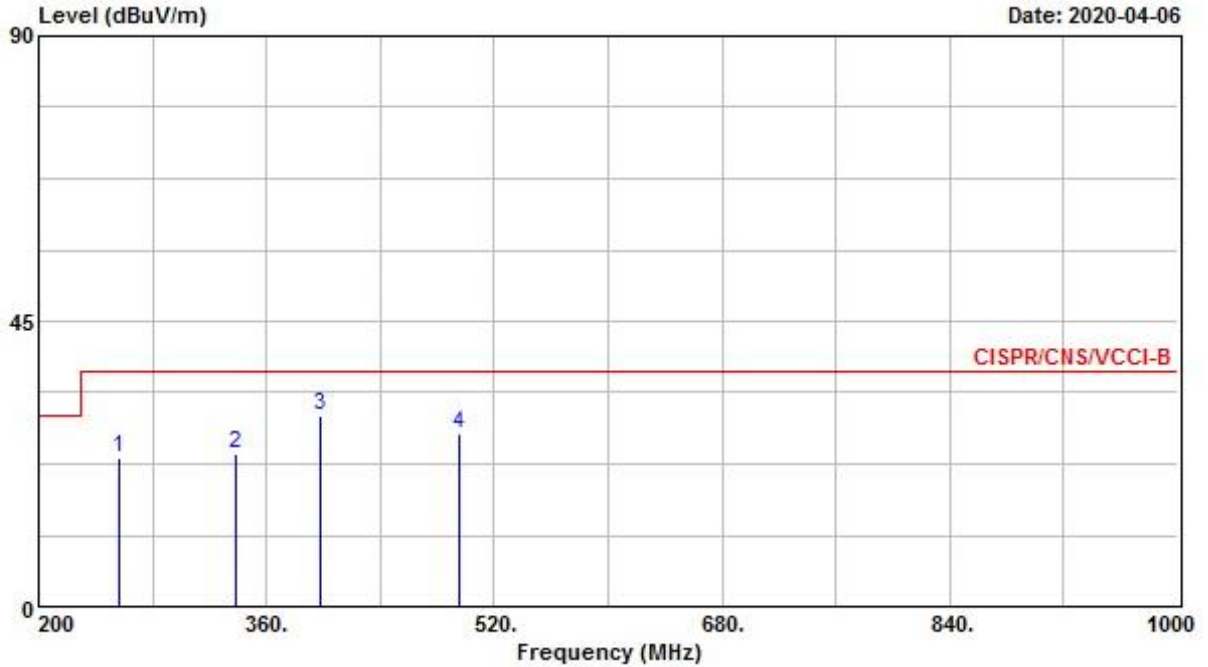

Freq	Level	Over Limit	Limit Line	ReadAntenna Level	Antenna Factor	Cable Loss	Preamp Factor	Remark	Ant Pos	Table Pos
MHz	dBuV/m	dB	dBuV/m	dBuV	dB/m	dB	dB		cm	deg
1	256.800	23.56	-13.44	37.00	29.85	18.52	3.05	27.86	Peak	---
2	338.400	24.21	-12.79	37.00	29.39	19.45	3.45	28.08	Peak	---
3	397.600	30.12	-6.88	37.00	33.74	21.06	3.82	28.50	Peak	---
4	495.200	27.34	-9.66	37.00	29.27	22.66	4.43	29.02	Peak	---



5.2. Radiated Emission above 1GHz

5.2.1.Limit

radiated emissions at frequencies above 1 GHz for Class B equipment			
Frequency range GHz	Measurement		Class B limits
	Distance (m)	Detector type / RBW / VBW	dB(µV/m)
1 – 2	3	Average / 1MHz / 1Hz	54
1 – 2		Peak / 1MHz / 3MHz	74

Required highest frequency for radiated measurement	
Highest internal frequency (F_x)	Highest measured frequency
$F_x \leq 108$ MHz	1 GHz
108 MHz < $F_x \leq 500$ MHz	2 GHz
500 MHz < $F_x \leq 1$ GHz	5 GHz
$F_x > 1$ GHz	$5 \times F_x$ up to a maximum of 40 GHz

5.2.2. Test Procedures

- a). Same test set up as below 1GHz radiated testing.
- b). The EUT was set 3m (1 – 2GHz) from the interference-receiving antenna which was mounted on the top of a variable height antenna tower.
- c). There should be absorber placed between the EUT and Antenna and its located size should let the test site meet CISPR16-1-4 requirement.
- d). The table was rotated 360 degrees to determine the position of the highest radiation.
- e). The measured using a test-receiver system with both a peak and CISPR average detector.
- f). If the EUT is having a Wireless or Bluetooth modular, install the filter at the input connector of test-receiver system.
- g). Set the DRG Horn Antenna at 1M height, then run the turn table to get the maximum noise reading from Horizontal and Vertical polarity separately. t the test-receiver system to Peak Detect Function and specified bandwidth with Maximum Hold Mode.
- h). When EUT locating on the turn-table, and its height is over 172cm (Antenna’s 3dB beam width of 6GHz is 27°), the DRG Horn Antenna must be raised up and descended down, then turning around the turn-table to get the maximum noise reading of the Horizontal and Vertical polarity separately. Note the maximum raise up height is same as the top of EUT.
- i). If emission level of the EUT in peak mode was 20dB lower than average limit (that means the emission level in peak mode also complies with the limit in average mode), then testing will be stopped and peak values of EUT will be reported, otherwise, the emissions will be measured in average mode again and reported.

5.2.3. Measurement Results Calculation

The measurand Level is calculated using:
Corrected Reading (dBµV/m) = Raw(Read Level)+AF(Antenna Factor)+CL(Cable Loss)-PA(Preamp Factor)
For example at 1980 MHz if the Antenna Factor is 26.19 dB/m, the cable loss is 4.08 dB, the measured voltage is 51.30 dBµV and the Preamp Factor is 33.34 dB, the signal strength would be calculated:
Corrected Reading (dBµV/m) = 51.30 dBµV + 26.19 dB/m + 4.08 dB + - 33.34 dB = 48.23 dBµV/m

5.2.4. Typical Test Setup Layout

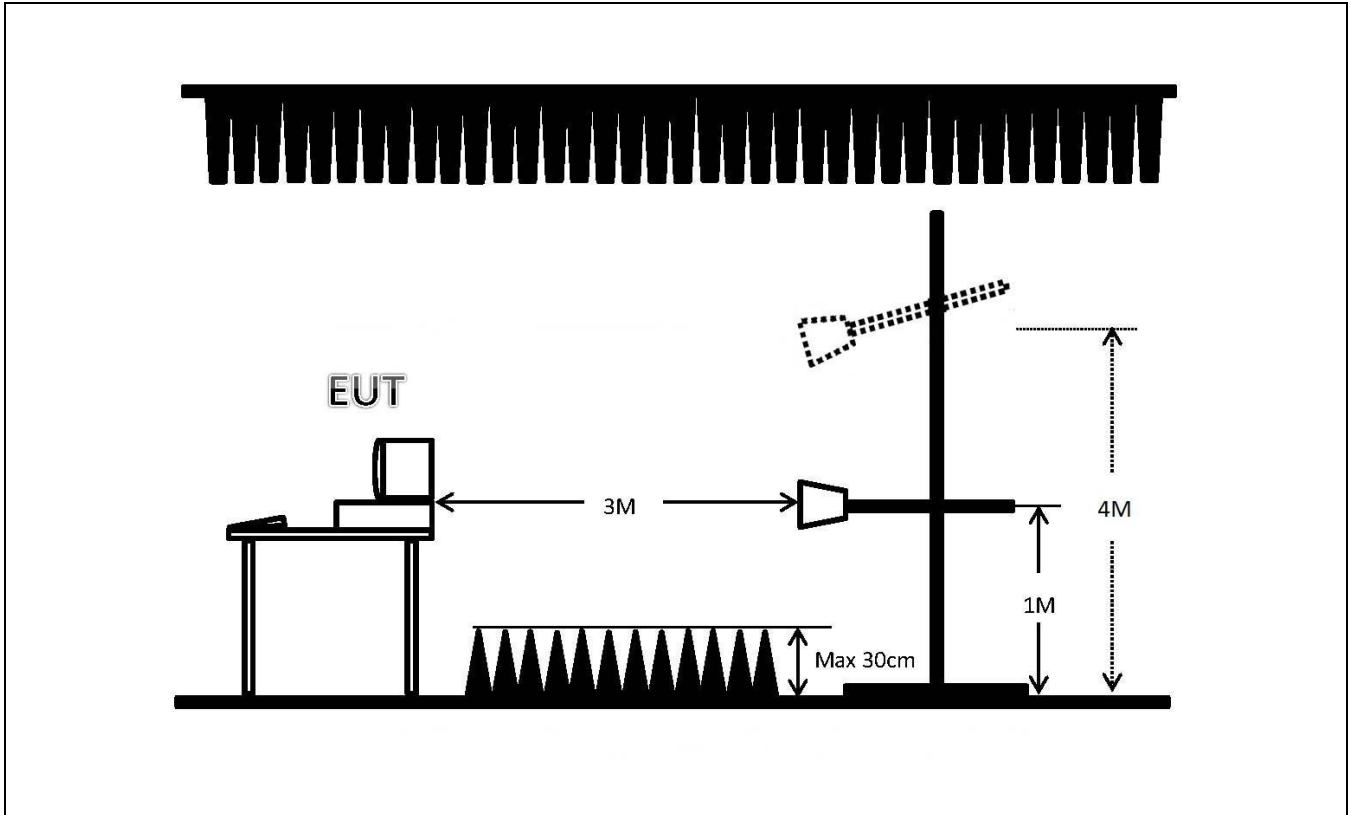



5.2.5. Test Result

Test mode	Mode 1		
Test frequency	Above 1GHz	Test Voltage	AC 120V / 60Hz
<p>■ The test was passed at the minimum margin that marked by the frame in the following data</p>			

Vertical

Mode 1

09/04/2020

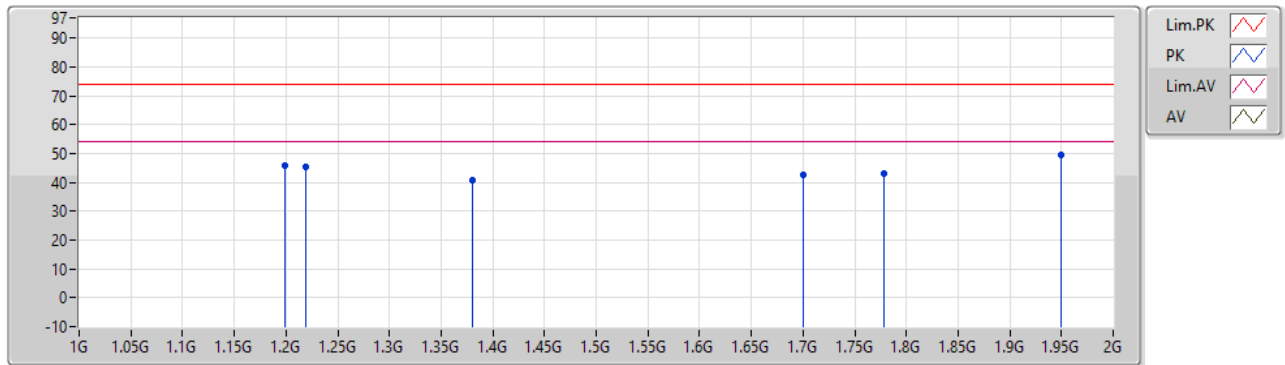

Type	Freq (Hz)	Level (dBuV/m)	Limit (dBuV/m)	Margin (dB)	Factor (dB)	Dist (m)	Condition	Azimuth (°)	Height (m)	Comment	Raw (dBuV)	AF (dB/m)	CL (dB)	PA (dB)
PK	1.199G	45.62	74.00	-28.38	-5.58	3	Vertical	-	-	-	51.20	25.00	3.30	33.88
PK	1.219G	45.21	74.00	-28.79	-5.39	3	Vertical	-	-	-	50.60	25.15	3.32	33.86
PK	1.38G	40.59	74.00	-33.41	-4.13	3	Vertical	-	-	-	44.72	26.04	3.48	33.65
PK	1.7G	42.38	74.00	-31.62	-4.58	3	Vertical	-	-	-	46.96	24.90	4.00	33.48
PK	1.778G	42.95	74.00	-31.05	-4.10	3	Vertical	-	-	-	47.05	25.21	4.16	33.47
PK	1.95G	49.60	74.00	-24.40	-3.05	3	Vertical	190	1	"Worst"	52.65	25.90	4.50	33.45



Horizontal

Mode 1

09/04/2020

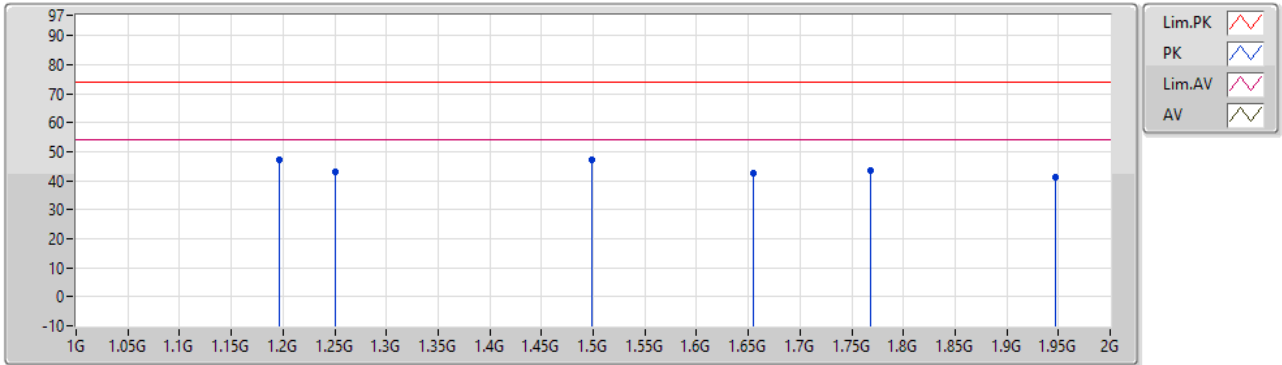

Type	Freq (Hz)	Level (dBuV/m)	Limit (dBuV/m)	Margin (dB)	Factor (dB)	Dist (m)	Condition	Azimuth (°)	Height (m)	Comment	Raw (dBuV)	AF (dB/m)	CL (dB)	PA (dB)
PK	1.196G	47.40	74.00	-26.60	-5.62	3	Horizontal	200	1	"Worst"	53.02	24.98	3.29	33.89
PK	1.25G	42.94	74.00	-31.06	-5.06	3	Horizontal	-	-	-	48.00	25.40	3.35	33.81
PK	1.499G	47.09	74.00	-26.91	-4.15	3	Horizontal	-	-	-	51.24	25.70	3.64	33.49
PK	1.655G	42.44	74.00	-31.56	-4.49	3	Horizontal	-	-	-	46.93	25.08	3.91	33.48
PK	1.768G	43.68	74.00	-30.32	-4.16	3	Horizontal	-	-	-	47.84	25.17	4.14	33.47
PK	1.947G	41.00	74.00	-33.00	-3.09	3	Horizontal	-	-	-	44.09	25.88	4.49	33.46



6. Uncertainty of Test Site

ISO/IEC 17025 requires that an estimate of the measurement uncertainties associated with the emissions test results be included in the report. The measurement uncertainties given below are based on a 95% confidence level (based on a coverage factor (k=2)).

6.1. Emission Test Measurement Uncertainty

Test Items	Test Site No.	U_{LAB}
Conducted Emissions	CO01-NH	2.7 dB
Radiated Emissions below 1GHz	OS03-NH	5.9 dB
Radiated Emissions above 1GHz	03CH04-HY	6.47 dB



7. List of Measuring Equipment Used

Conducted Emission - Test Date: 06/Apr/2020

Instrument	Manufacturer	Model No.	Serial No.	Characteristics	Calibration Date	Remark
EMI Receiver	R&S	ESR3	102318	9K Hz – 3.6 GHz	30/Jul/2019	Conduction (CO01-NH)
LISN	SCHAFFNER	NNB41	06/10024	9kHz - 30MHz	27/Dec/2019	Conduction (CO01-NH)
LISN	ROLF HEINE	NNB-2/16Z	99079	9kHz - 30MHz	10/Jan/2020	Conduction (CO01-NH)
Power Filter	CORCOM	MR12030	N/A	30A*2	NCR	Conduction (CO01-NH)
RF Cable-CON	Suhner Switzerland	RG223/U	CB004	9kHz - 30MHz	26/Dec/2019	Conduction (CO01-NH)
software	Audix	E3	6.12160806	-	NCR	Conduction (CO01-NH)

Note: Calibration Interval of instruments listed above is one year. NCR: No Calibration Request.

Radiated Emission below 1GHz - Test Date: 06/Apr/2020

Instrument	Manufacturer	Model No.	Serial No.	Characteristics	Calibration Date	Remark
Open Area Test Site	SPORTON	OATS-10	OS03-NH	30 MHz - 1 GHz 10m, 3m	22/Oct/2019	Radiation (OS03-NH)
Amplifier	HP	8447D	2944A08292	0.1 MHz - 1.3 GHz	04/Jul/2019	Radiation (OS03-NH)
Spectrum Analyzer	R&S	FSP7	838858/038	9 kHz – 7GHz	16/Apr/2019	Radiation (OS03-NH)
Receiver	R&S	ESCS30	838251/002	9 kHz –2.75 GHz	05/Jul/ 2019	Radiation (OS03-NH)
Bilog Antenna With 5dB Attenuator	CHASE	CBL6112D	25234	30 MHz - 2 GHz	27/Apr/2019	Radiation (OS03-NH)
Turn Table	EMCO	2080	9805-2065	0 - 360 degree	NCR	Radiation (OS03-NH)
Antenna Mast	EMCO	2075	9804-2151	1 m - 4 m	NCR	Radiation (OS03-NH)
RF Cable-R10m	HSCN	RG213U	2X11N	30 MHz - 1 GHz	22/Jul/2019	Radiation (OS03-NH)
Software	Audix	E3	Ver.4	-	NCR	Radiation (OS03-NH)

Note: Calibration Interval of instruments listed above is one year. NCR: No Calibration Request.

**Radiated Emission above 1GHz - Test Date: 09/Apr/2020**

Instrument	Manufacturer	Model No.	Serial No.	Characteristics	Calibration Date	Remark
EMI Test Receiver	R&S	ESU-26	100422	20Hz ~ 26.5GHz	23/Oct/2019	Radiation (03CH04-HY)
Turn Table	Chaintek	3000	MF7802056	0 ~ 360 degree	NCR	Radiation (03CH04-HY)
Antenna Mast	MF	MF-7802	MF780208163	1 m ~ 4 m	NCR	Radiation (03CH04-HY)
3m Semi Anechoic Chamber (Site V.S.W.R)	RIKEN	3m SAC	03CH04-HY	1 GHz ~ 18 GHz 3m	27/Feb/2020	Radiation (03CH04-HY)
Microwave Preamplifier	Agilent	8449B	3008A02364	1GHz ~ 26.5GHz	12/Dec/2019	Radiation (03CH04-HY)
Horn Antenna	SCHWARZBECK	BBHA9120	BBHA 9120 D-1130	1 GHz ~ 18 GHz	04/Nov/2019	Radiation (03CH04-HY)
RF Cable-HIGH	HUBER+SUHNER	SUOFLEX 104	SN805197/4+MY39497	1 GHz ~ 18 GHz	13/Mar/2020	Radiation (03CH04-HY)
Software	Sporton	SENSE-EMI	V5.10.7.2	-	NCR	Radiation (03CH04-HY)

Note: Calibration Interval of instruments listed above is one year. NCR: No Calibration Request.

Appendix A. Test Photos

1. Photographs of Conducted Emissions Test Configuration

Front View



Side View

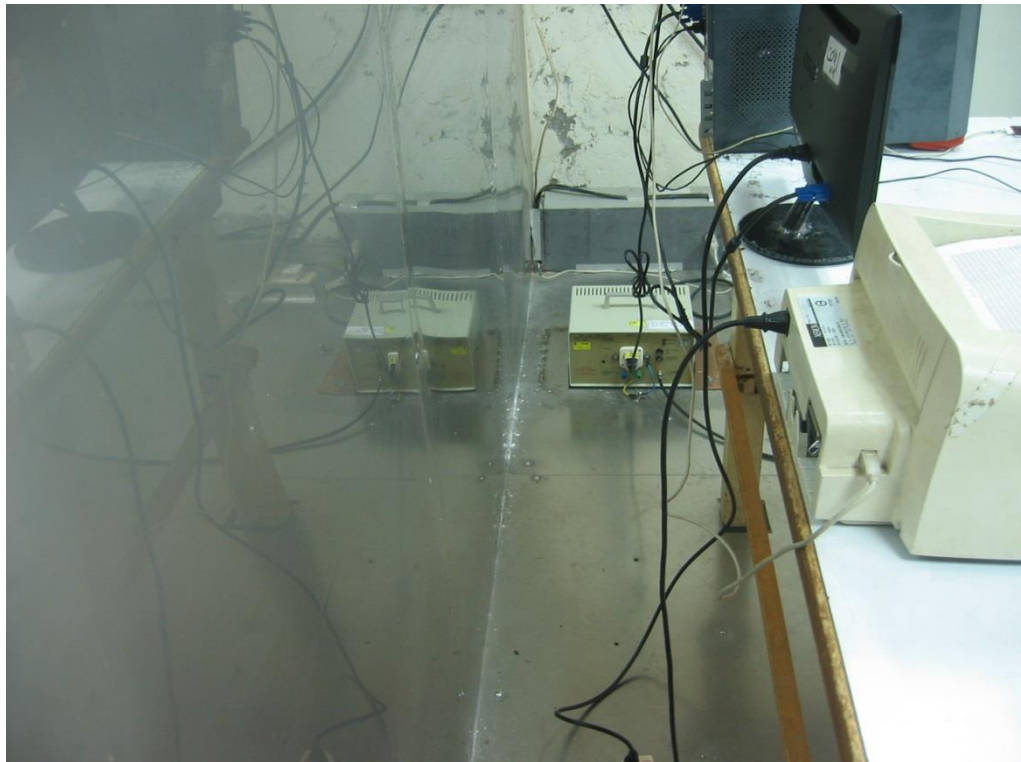

Under Table View

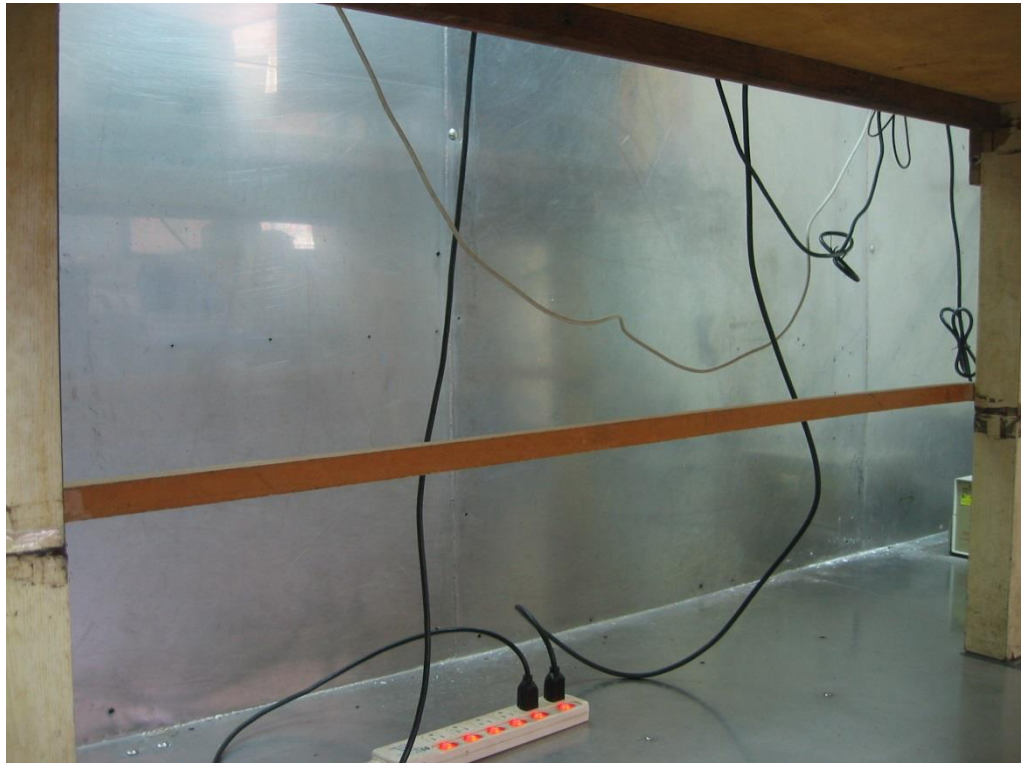

2. Photographs of Radiated Emissions Test Configuration

For radiated emissions below 1GHz

Front View



Rear View



For radiated emissions above 1GHz

Front View

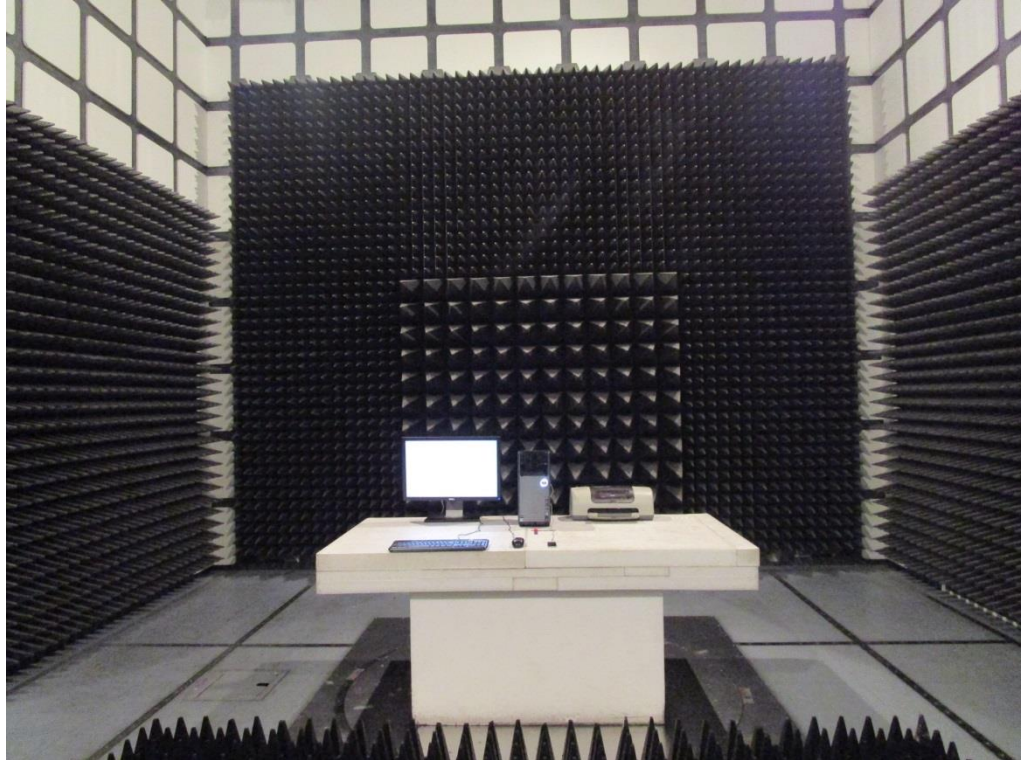

Rear View



————THE END————