

FCC Test Report

Product Name : M.2 SSD
Model No. : M.2 T80 A201-M

Applicant : Apacer Technology Inc
Address : 1F., No.32, Zhongcheng Rd., Tucheng Dist., New
Taipei City 236, Taiwan (R.O.C)

Date of Receipt : 2014/04/28
Issued Date : 2014/05/02
Report No. : 1450028R-ITUSP03V00
Report Version : V1.0



The test results relate only to the samples tested.

The test results shown in the test report are traceable to the national/international standard through the calibration of the equipment and evaluated measurement uncertainty herein.

This report must not be used to claim product endorsement by TAF or any agency of the government.

The test report shall not be reproduced without the written approval of Quietek Corporation.

Test Report

Issued Date : 2014/05/02
 Report No. : 1450028R-ITUSP03V00



Product Name : M.2 SSD
 Applicant : Apacer Technology Inc.
 Address : 1F., No.32, Zhongcheng Rd., Tucheng Dist., New Taipei City
 236, Taiwan (R.O.C)
 Manufacturer : Apacer Technology Inc.
 Model No. : M.2 T80 A201-M
 EUT Rated Voltage : Power by PC
 EUT Test Voltage : AC 120 V / 60 Hz
 Trade Name : Apacer
 Applicable Standard : FCC CFR Title 47 Part 15 Subpart B: 2013, Class B
 CISPR 22: 2008, ANSI C63.4: 2009
 Test Result : Complied
 Performed Location : Quietek Corporation (Linkou Laboratory)
 No.5-22, Ruishukeng, Linkou Dist., New Taipei City 24451,
 Taiwan, R.O.C.
 TEL:+866-2-8601-3788 / FAX:+886-2-8601-3789

Documented By : 

 (Senior Adm. Specialist / Joanne Lin)

Reviewed By : 

 (Senior Engineer / Leo Lin)

Approved By : 

 (Director / Vincent Lin)

Laboratory Information

We, **Quietek Corporation**, are an independent EMC and safety consultancy that was established the whole facility in our laboratories. The test facility has been accredited/accepted (audited or listed) by the following related bodies in compliance with ISO 17025, EN 45001 and specified testing scopes:

Taiwan R.O.C.	:	BSMI, NCC, TAF
Norway	:	DNV
USA	:	FCC
Japan	:	VCCI

The related certificate for our laboratories about the test site and management system can be downloaded from Quietek Corporation's Web Site : <http://www.quietek.com/tw/ctg/cts/accreditations.htm>

The address and introduction of Quietek Corporation's laboratories can be founded in our Web site : <http://www.quietek.com/>

If you have any comments, Please don't hesitate to contact us. Our contact information is as below:

HsinChu Testing Laboratory :

No.75-2, 3rd Lin, Wangye Keng, Yonghxing Tsuen, Qionglin Shiang, Hsinchu County 307, Taiwan, R.O.C.

TEL:+886-3-592-8858 / FAX:+886-3-592-8859 E-Mail : service@quietek.com

LinKou Testing Laboratory :

No.5-22, Ruishukeng, Linkou Dist., New Taipei City 24451, Taiwan, R.O.C.

TEL : 886-2-8601-3788 / FAX : 886-2-8601-3789 E-Mail : service@quietek.com

Suzhou (China) Testing Laboratory :

No. 99 Hongye Rd., Suzhou Industrial Park Loufeng Hi-Tech Development Zone., Suzhou,China.

TEL : +86-512-6251-5088 / FAX : +86-512-6251-5098 E-Mail : service@quietek.com

TABLE OF CONTENTS

Description	Page
1. General Information	5
1.1. EUT Description.....	5
1.2. Mode of Operation	5
1.3. Tested System Details	7
1.4. Configuration of Tested System	8
1.5. EUT Exercise Software.....	9
2. Technical Test	10
2.1. Summary of Test Result.....	10
2.2. List of Test Equipment	11
2.3. Measurement Uncertainty.....	12
2.4. Test Environment.....	13
3. Conducted Emission	14
3.1. Test Specification.....	14
3.2. Test Setup.....	14
3.3. Limit.....	14
3.4. Test Procedure	15
3.5. Test Result.....	16
3.6. Test Photograph	22
4. Radiated Emission.....	23
4.1. Test Specification.....	23
4.2. Test Setup.....	23
4.3. Limit.....	24
4.4. Test Procedure	25
4.5. Test Result.....	26
4.6. Test Photograph	30
5. Attachment.....	32
EUT Photograph.....	32

1. General Information**1.1. EUT Description**

Product Name	M.2 SSD
Trade Name	Apacer
Model No.	M.2 T80 A201-M

1.2. Mode of Operation

QuieTek has verified the construction and function in typical operation. All the test modes were carried out with the EUT in normal operation, which was shown in this test report and defined as:

Pre-Test Mode	
Mode 1: Normal Operation	
Final Test Mode	
Emission	Mode 1: Normal Operation

1.3. Tested System Details

The types for all equipments, plus descriptions of all cables used in the tested system (including inserted cards) are:

Product	Manufacturer	Model No.	Serial No.	Power Cord
1 Monitor	DELL	U2410	CN-0J257M-728-011-04NL	Non-Shielded, 1.8m
2 PC	DELL	Vostro230	1R7Z62S	Non-Shielded, 1.8m
3 Printer	EPSON	StyLus C63	FAPY094331	Non-Shielded, 1.8m
4 Modem	ACEEX	DM-1414	0102027554	Non-Shielded, 1.8m
5 IPod nano	Apple	A1236	YM823SUQY0P	N/A
6 Microphone & Earphone	Ergotech	ET-E201	N/A	N/A
7 Keyboard	Logitech	Y-SAL85	SY917UK	N/A
8 Mouse	Logitech	M-SBM96B	810-000440	N/A

1.4. Configuration of Tested System

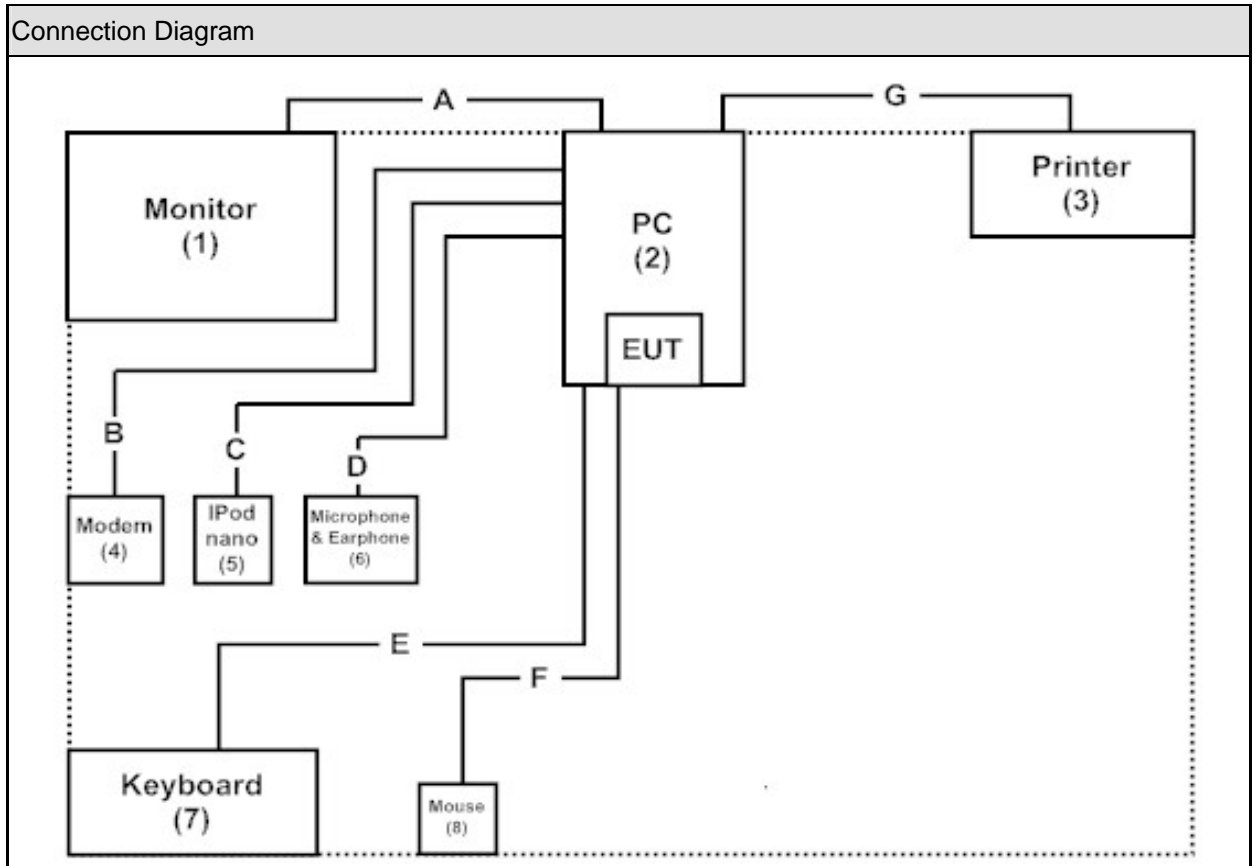

Signal Cable Type		Signal cable Description
A	D-SUB Cable	Shielded, 1.8m, with two ferrite cores bonded.
B	RS-232 Cable	Shielded, 1.5m
C	Audio Cable	Non-Shielded, 1.6m
D	Microphone & Earphone Cable	Non-Shielded, 1.6m
E	Keyboard Cable	Shielded, 1.8m
F	Mouse Cable	Shielded, 1.8m
G	USB Cable	Shielded, 1.8m

1.5. EUT Exercise Software

1	Setup the EUT and simulators as shown on 1.4.
2	Turn on the power of all equipments.
3	All the features of the EUT operation normally.

2. Technical Test

2.1. Summary of Test Result

- No deviations from the test standards
- Deviations from the test standards as below description:

Emission			
Performed Item	Normative References	Test Performed	Deviation
Conducted Emission	FCC CFR Title 47 Part 15 Subpart B: 2013 Class B, ANSI C63.4: 2009	Yes	No
Radiated Emission	FCC CFR Title 47 Part 15 Subpart B: 2013 Class B, ANSI C63.4: 2009	Yes	No

2.2. List of Test Equipment

Conducted Emission / SR2

Instrument	Manufacturer	Type No.	Serial No	Cal. Date
EMI Test Receiver	R&S	ESCI	100648	2013/11/22
LISN	R&S	ESH3-Z5	836679/020	2014/03/18
LISN	R&S	ENV216	100086	2014/04/10
Pulse Limiter	R&S	ESH3-Z2	100324	2014/03/28
Coaxial Cable	QTK(Arnist)	RG 400	LC017-RG	2013/06/26

Radiated Emission / Site2

Instrument	Manufacturer	Type No.	Serial No	Cal. Date
Bilog Antenna	Schaffner Chase	CBL6112B	2921	2013/05/06
EMI Test Receiver	R&S	ESCS 30	100123	2013/07/09
Coaxial Cable	QTK(Arnist)	RG 214	LC002-RG	2013/06/18
Coaxial Switch	Arnist	MP59B	6200436230	2013/06/18
Site2 NSA	QTK	N/A	N/A	2013/06/18

Radiated Emission / CB7

Instrument	Manufacturer	Type No.	Serial No	Cal. Date
EMI Test Receiver	R&S	ESU26	100433	2013/07/29
Horn Antenna	ETS-Lindgren	3117	00135205	2014/03/26
Horn Antenna	SCHWARZBECK	9120D	576	2013/11/20
Pre-Amplifier	Quietek	AP-180C	CHM/071920	2013/06/24
CB7 VSWR	QTK	N/A	N/A	2013/07/25

2.3. Measurement Uncertainty

Conducted Emission

The measurement uncertainty is evaluated as ± 2.26 dB.

Radiated Emission

The measurement uncertainty is evaluated as ± 3.19 dB.

2.4. Test Environment

Performed Item	Items	Required	Actual
Conducted Emission	Temperature (°C)	15-35	23.9
	Humidity (%RH)	25-75	52
	Barometric pressure (mbar)	860-1060	950-1000
Radiated Emission	Temperature (°C)	15-35	24.9
	Humidity (%RH)	25-75	38
	Barometric pressure (mbar)	860-1060	950-1000

3. Conducted Emission

3.1. Test Specification

According to Standard : FCC Part 15 Subpart B, ANSI C63.4

3.2. Test Setup

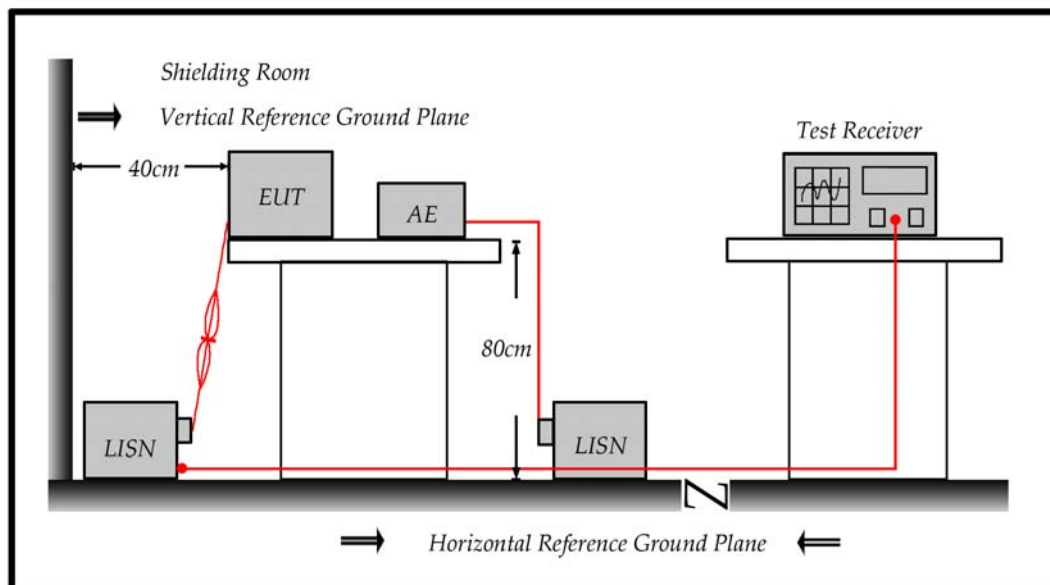

3.3. Limit

Limits		
Frequency (MHz)	QP (dBuV)	AV (dBuV)
0.15 - 0.50	66 - 56	56 - 46
0.50-5.0	56	46
5.0 - 30	60	50

Remarks: In the above table, the tighter limit applies at the band edges.

3.4. Test Procedure

The EUT and simulators are connected to the main power through a line impedance stabilization network (L.I.S.N.). This provides a 50 ohm /50uH coupling impedance for the measuring equipment. The peripheral devices are also connected to the main power through a LISN that provides a 50ohm/50uH coupling impedance with 50ohm termination.

(Please refers to the block diagram of the test setup and photographs.)

Both sides of A.C. line are checked for maximum conducted interference. In order to find the maximum emission, the relative positions of equipment and all of the interface cables must be changed on conducted measurement.

Conducted emissions were invested over the frequency range from 0.15MHz to 30MHz using a receiver bandwidth of 9kHz.

3.5. Test Result

Site : SR2	Time : 2014/04/29 - 10:38
Limit : CISPR_B_00M_QP	Margin : 10
EUT : M.2 SSD	Probe : ENV_216_L1 - Line1
Power : AC 120V/60Hz	Note : Mode 1

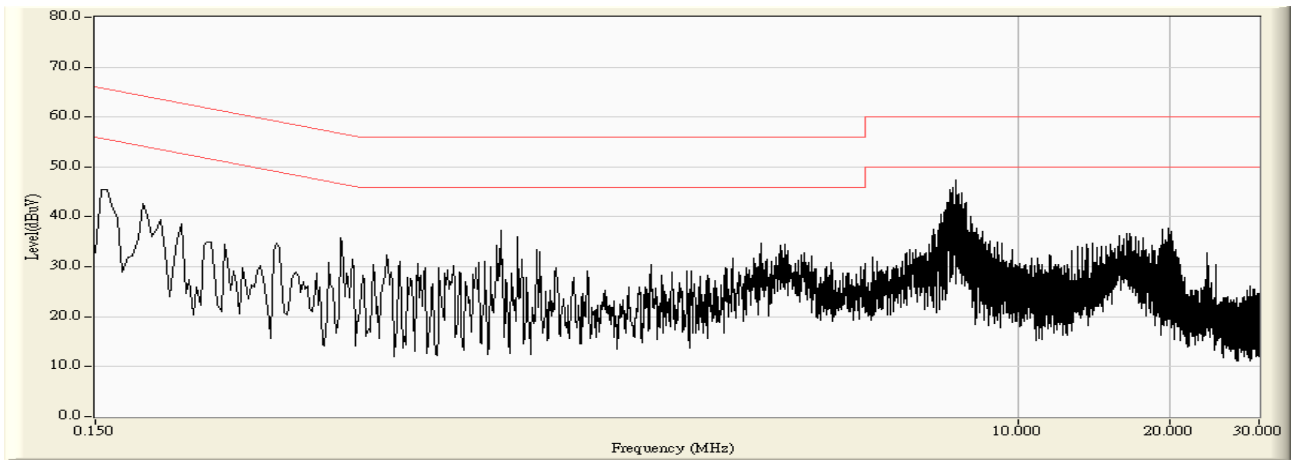

Site : SR2	Time : 2014/04/29 - 10:39
Limit : CISPR_B_00M_QP	Margin : 0
EUT : M.2 SSD	Probe : ENV_216_L1 - Line1
Power : AC 120V/60Hz	Note : Mode 1

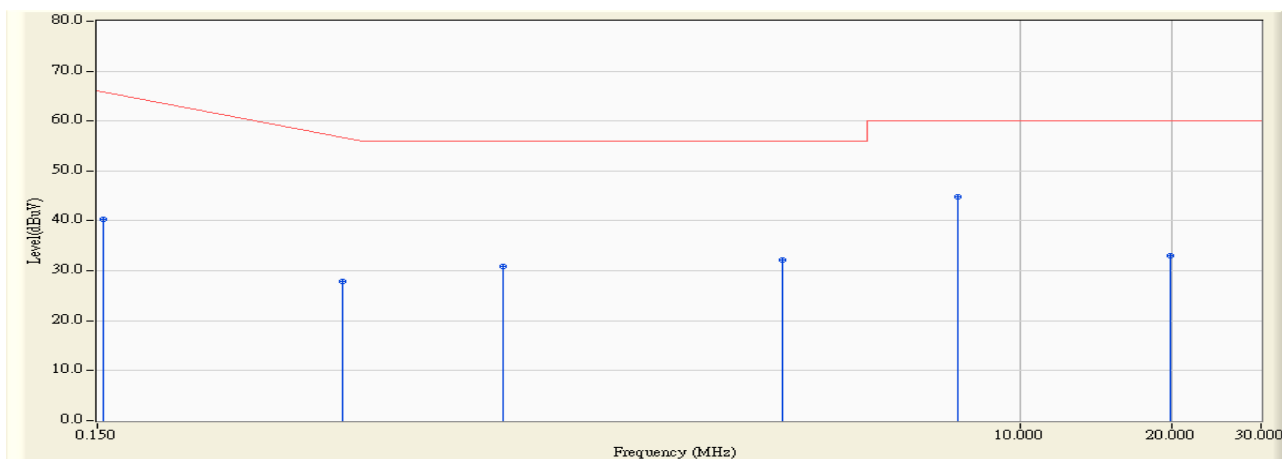

		Frequency (MHz)	Correct Factor (dB)	Reading Level (dBuV)	Measure Level (dBuV)	Margin (dB)	Limit (dBuV)	Detector Type
1		0.154	9.753	30.505	40.258	-25.628	65.886	QUASIPeAK
2		0.458	9.742	18.161	27.903	-29.297	57.200	QUASIPeAK
3		0.950	9.754	21.178	30.932	-25.068	56.000	QUASIPeAK
4		3.386	9.817	22.249	32.066	-23.934	56.000	QUASIPeAK
5	*	7.550	9.961	34.923	44.884	-15.116	60.000	QUASIPeAK
6		19.870	10.151	22.808	32.959	-27.041	60.000	QUASIPeAK

Note:

1. All Reading Levels are Quasi-Peak and average value.
2. " * ", means this data is the worst emission level.
3. Measurement Level = Reading Level + Correct Factor

Site : SR2	Time : 2014/04/29 - 10:39
Limit : CISPR_B_00M_AV	Margin : 0
EUT : M.2 SSD	Probe : ENV_216_L1 - Line1
Power : AC 120V/60Hz	Note : Mode 1

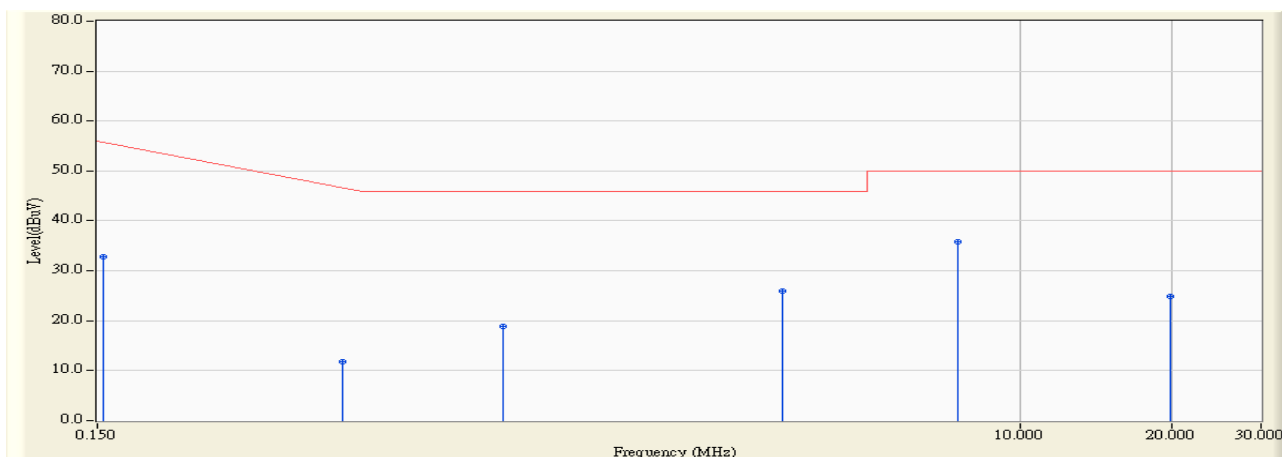

	Frequency (MHz)	Correct Factor (dB)	Reading Level (dBuV)	Measure Level (dBuV)	Margin (dB)	Limit (dBuV)	Detector Type
1	0.154	9.753	23.028	32.780	-23.106	55.886	AVERAGE
2	0.458	9.742	1.977	11.719	-35.481	47.200	AVERAGE
3	0.950	9.754	9.070	18.825	-27.175	46.000	AVERAGE
4	3.386	9.817	16.072	25.890	-20.110	46.000	AVERAGE
5	* 7.550	9.961	25.782	35.744	-14.256	50.000	AVERAGE
6	19.870	10.151	14.628	24.779	-25.221	50.000	AVERAGE

Note:

1. All Reading Levels are Quasi-Peak and average value.
2. " * ", means this data is the worst emission level.
3. Measurement Level = Reading Level + Correct Factor

Site : SR2	Time : 2014/04/29 - 10:40
Limit : CISPR_B_00M_QP	Margin : 10
EUT : M.2 SSD	Probe : ENV_216_N - Line2
Power : AC 120V/60Hz	Note : Mode 1

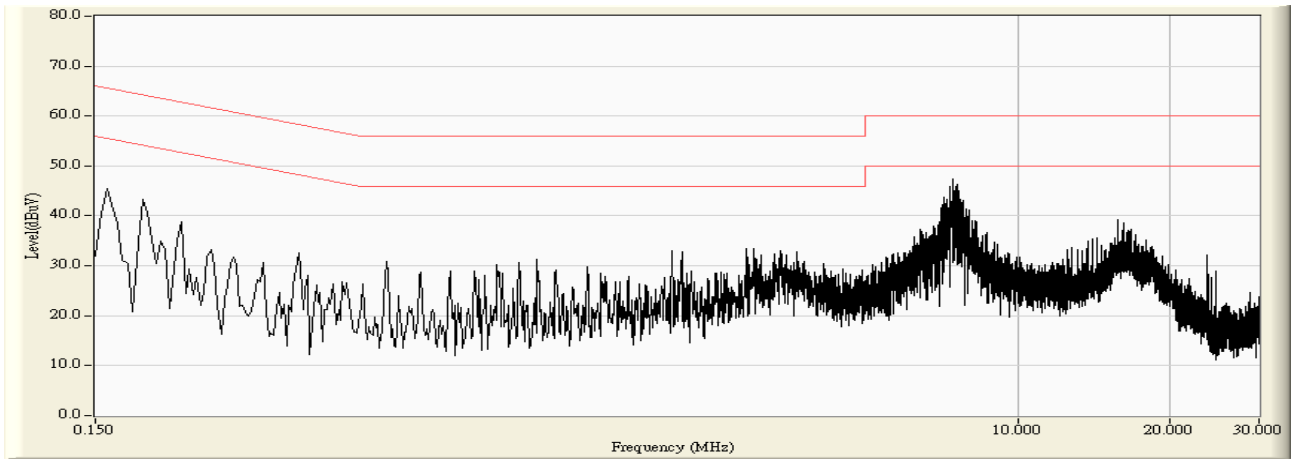

Site : SR2	Time : 2014/04/29 - 10:41
Limit : CISPR_B_00M_QP	Margin : 0
EUT : M.2 SSD	Probe : ENV_216_N - Line2
Power : AC 120V/60Hz	Note : Mode 1

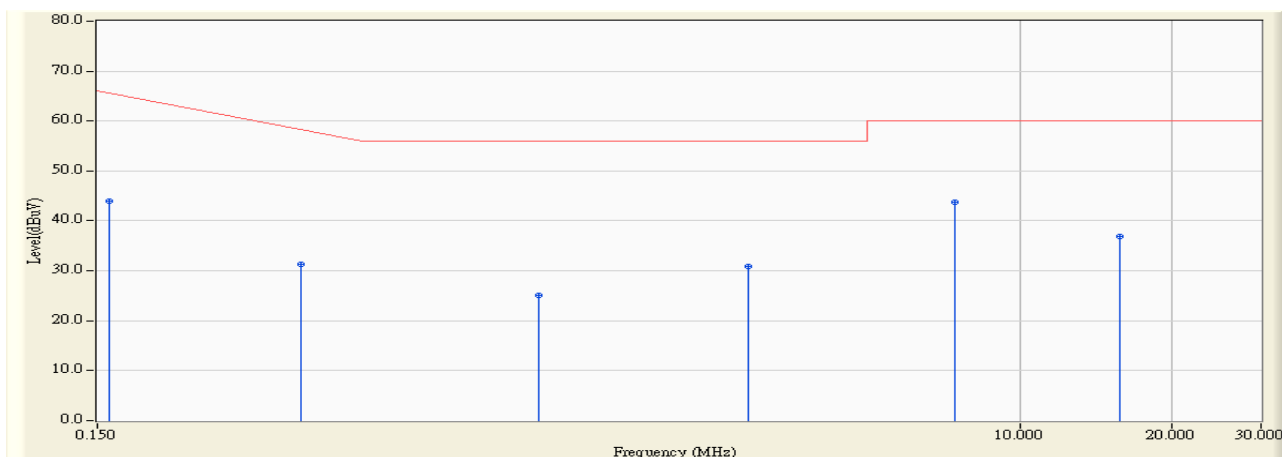

		Frequency (MHz)	Correct Factor (dB)	Reading Level (dBuV)	Measure Level (dBuV)	Margin (dB)	Limit (dBuV)	Detector Type
1		0.158	9.741	34.265	44.006	-21.765	65.771	QUASPEAK
2		0.378	9.732	21.542	31.274	-28.212	59.486	QUASPEAK
3		1.122	9.745	15.441	25.186	-30.814	56.000	QUASPEAK
4		2.914	9.782	21.119	30.901	-25.099	56.000	QUASPEAK
5	*	7.426	9.959	33.762	43.721	-16.279	60.000	QUASPEAK
6		15.806	10.230	26.666	36.896	-23.104	60.000	QUASPEAK

Note:

1. All Reading Levels are Quasi-Peak and average value.
2. " * ", means this data is the worst emission level.
3. Measurement Level = Reading Level + Correct Factor

Site : SR2	Time : 2014/04/29 - 10:41
Limit : CISPR_B_00M_AV	Margin : 0
EUT : M.2 SSD	Probe : ENV_216_N - Line2
Power : AC 120V/60Hz	Note : Mode 1

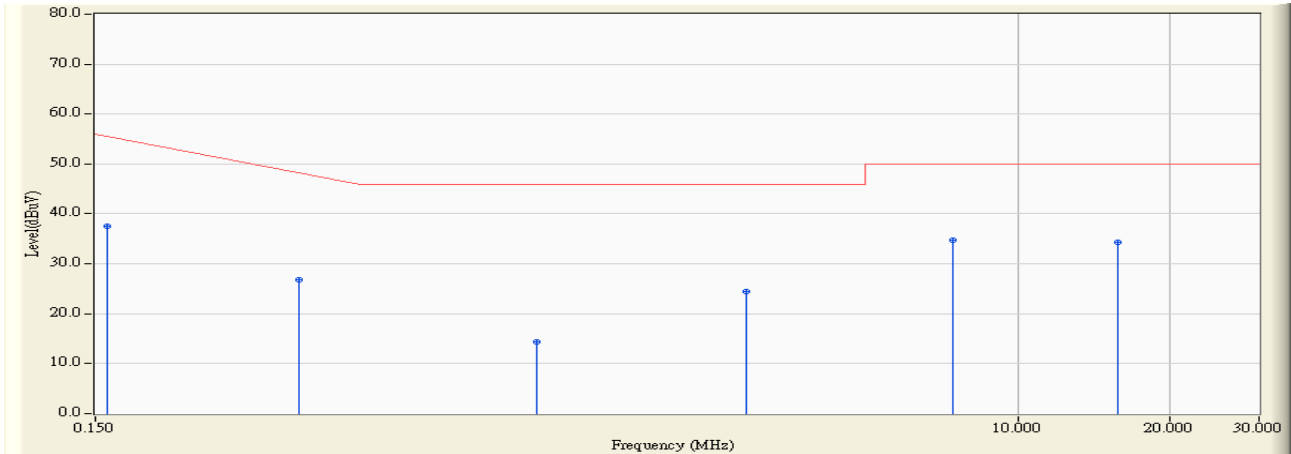

		Frequency (MHz)	Correct Factor (dB)	Reading Level (dBuV)	Measure Level (dBuV)	Margin (dB)	Limit (dBuV)	Detector Type
1		0.158	9.741	27.705	37.446	-18.325	55.771	AVERAGE
2		0.378	9.732	17.096	26.827	-22.659	49.486	AVERAGE
3		1.122	9.745	4.658	14.403	-31.597	46.000	AVERAGE
4		2.914	9.782	14.682	24.464	-21.536	46.000	AVERAGE
5	*	7.426	9.959	24.805	34.764	-15.236	50.000	AVERAGE
6		15.806	10.230	24.049	34.279	-15.721	50.000	AVERAGE

Note:

1. All Reading Levels are Quasi-Peak and average value.
2. " * ", means this data is the worst emission level.
3. Measurement Level = Reading Level + Correct Factor

3.6. Test Photograph

Test Mode : Mode 1: Normal Operation

Description : Front View of Conducted Test

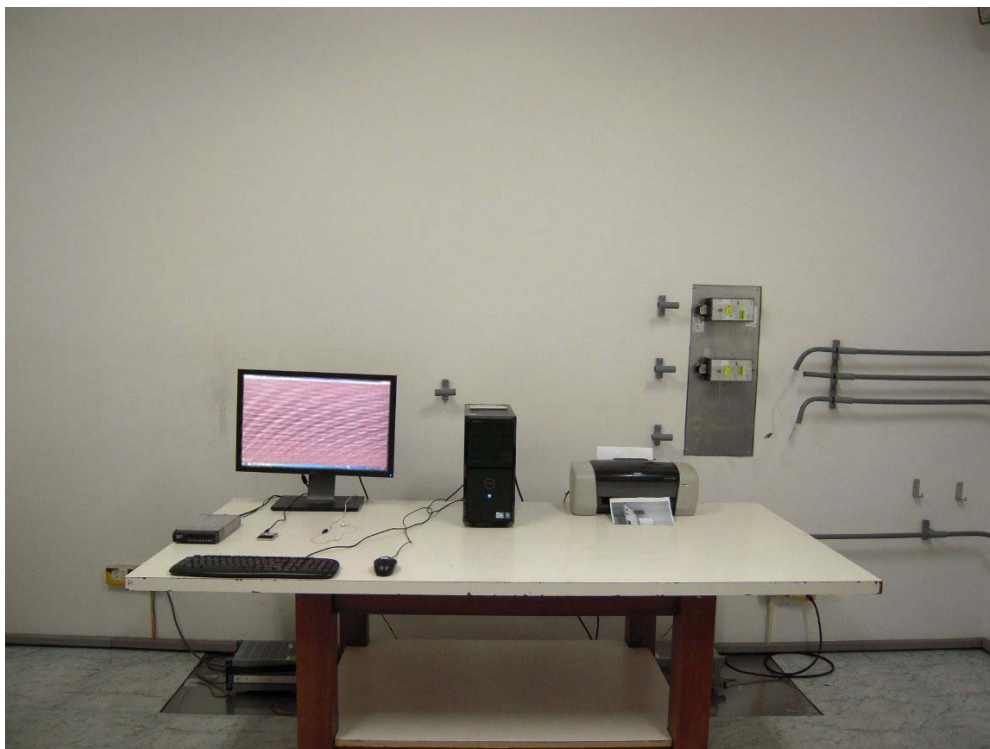

Test Mode : Mode 1: Normal Operation

Description : Back View of Conducted Test

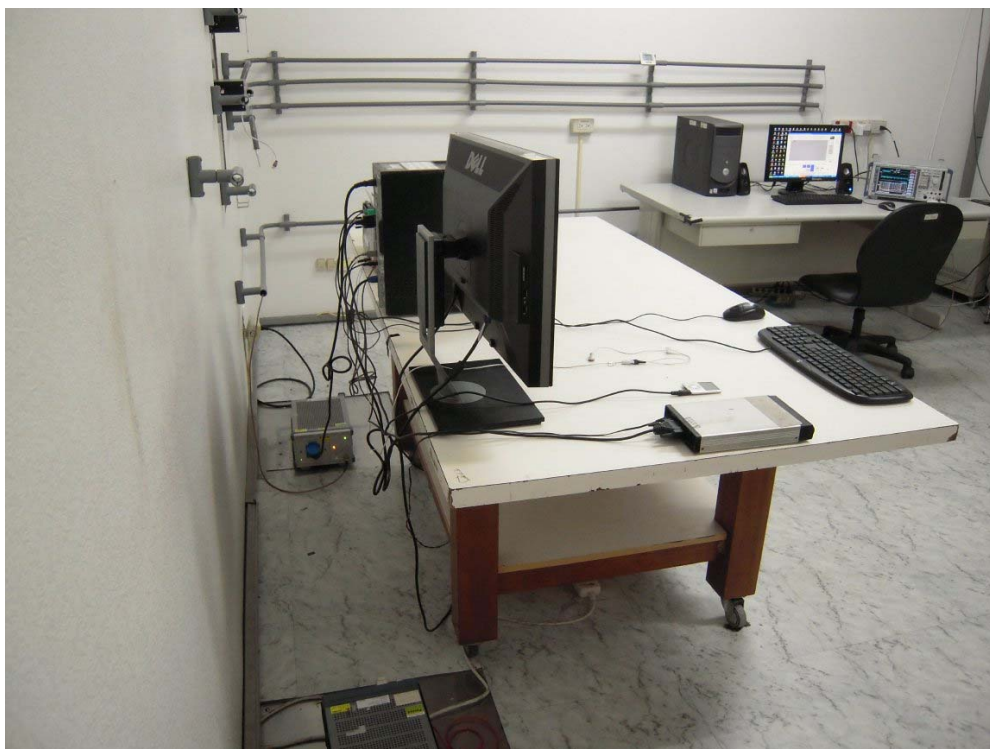

4. Radiated Emission

4.1. Test Specification

According to EMC Standard : FCC Part 15 Subpart B, ANSI C63.4

4.2. Test Setup

Under 1GHz Test Setup:

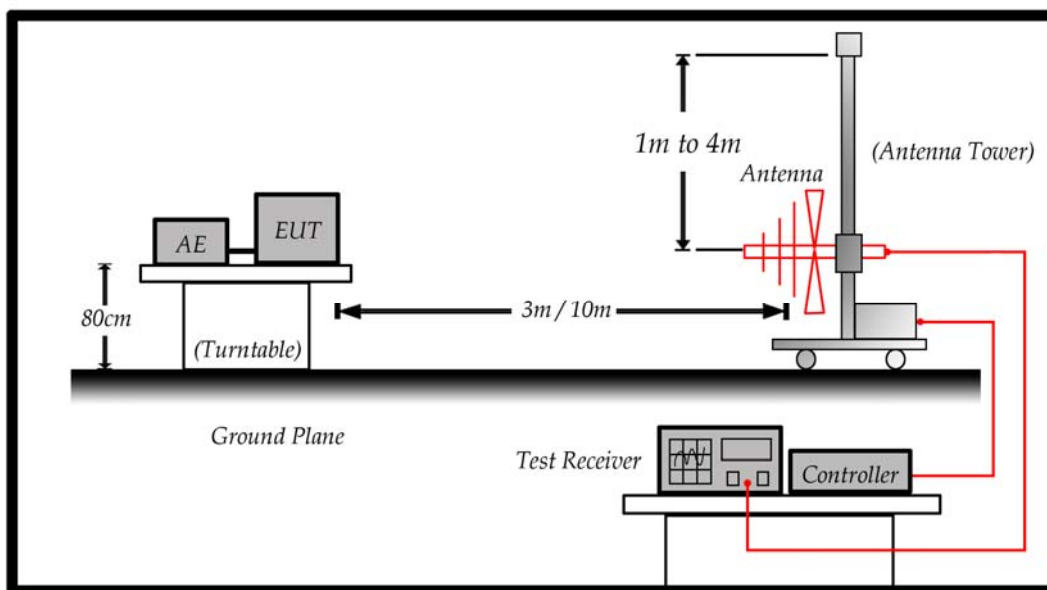

Above 1GHz Test Setup:

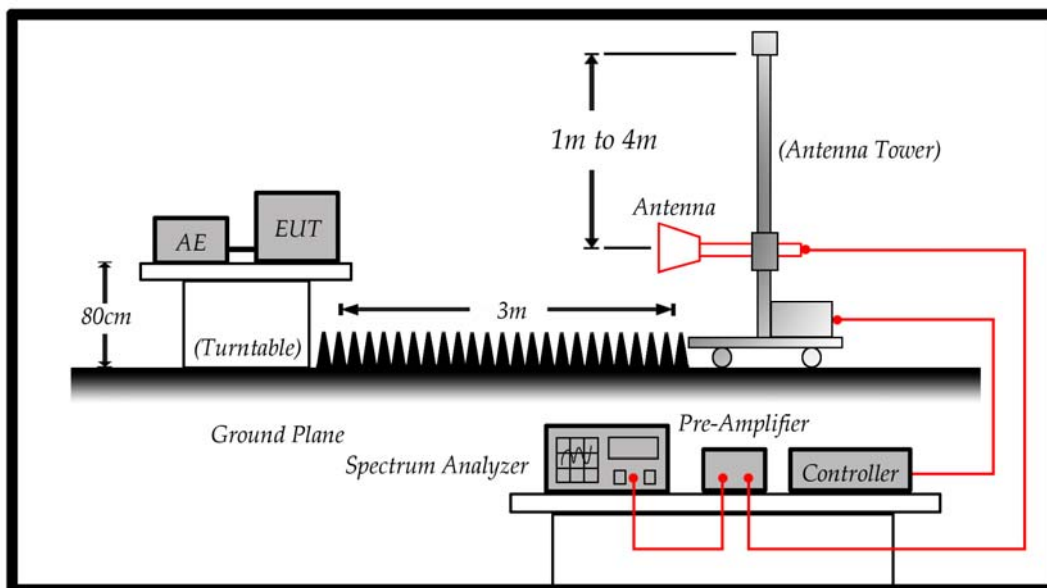

4.3. Limit

Under 1GHz test shall not exceed the following value:

Limits		
Frequency (MHz)	Distance (m)	dBuV/m
30 – 230	10	30
230 – 1000	10	37

Remark:

1. The tighter limit shall apply at the edge between two frequency bands.
2. Distance refers to the distance in meters between the measuring instrument antenna and the closed point of any part of the device or system.

Above 1GHz test shall not exceed the following value:

FCC Part 15 Subpart B Paragraph 15.109 Limits (dBuV/m)		
Frequency (MHz)	Distance (m)	dBuV/m
30-88	3	40
88-216	3	43.5
216-960	3	46
Above 960	3	54

Remark:

1. The tighter limit shall apply at the edge between two frequency bands.
2. Distance refers to the distance in meters between the measuring instrument antenna and the closed point of any part of the device or system.
3. RF Voltage (dBuV/m) = 20 log RF Voltage (uV/m)

4.4. Test Procedure

The EUT and its simulators are placed on a turn table which is 0.8 meter above ground.

The turn table can rotate 360 degrees to determine the position of the maximum emission level and the antenna can move up and down between 1 meter and 4 meters to find out the maximum emission level.

Both horizontal and vertical polarization of the antenna are set on measurement. In order to find the maximum emission, all of the interface cables must be manipulated on radiated measurement.

For an unintentional radiator, including a digital device, the spectrum shall be investigated from the lowest radio frequency signal generated or used in the device, without going below the lowest frequency for which a radiated emission limit is specified, up to the frequency shown in the following table:

Highest frequency generated or used in the device or on which the device operates or tunes (MHz)	Upper frequency of measurement range (MHz)
Below 1.705	30
1.705 – 108	1000
108 – 500	2000
500 – 1000	5000
Above 1000	5 th harmonic of the highest frequency or 40 GHz, whichever is lower

On any frequency or frequencies below or equal to 1000 MHz, the radiated limits shown are based on measuring equipment employing a quasi-peak detector function and above 1000 MHz, the radiated limits shown are based measuring equipment employing an average detector function.

When average radiated emission measurement are included emission measurement Above 1000 MHz, there also is a limit on the radio frequency emissions, as measured using instrumentation with a peak detector function, corresponding to 20 dB above the maximum permitted average limit.

For class A, the measurement distance between the EUT and antenna is 10 meters for under 1GHz and above 1GHz.

For class B, the measurement distance between the EUT and antenna is 10 meters for under 1GHz and 3 meters for above 1GHz.

The bandwidth below 1GHz setting on the field strength meter (R&S Test Receiver ESCS 30) is 120 kHz and above 1GHz is 1MHz.

4.5. Test Result

Site : Site2	Time : 2014/04/28 - 14:10
Limit : CISPR_B_10M_QP	Margin : 6
EUT : M.2 SSD	Probe : Site2_CBL6112_10M_2705 - HORIZONTAL
Power : AC 120V/60Hz	Note : Mode 1

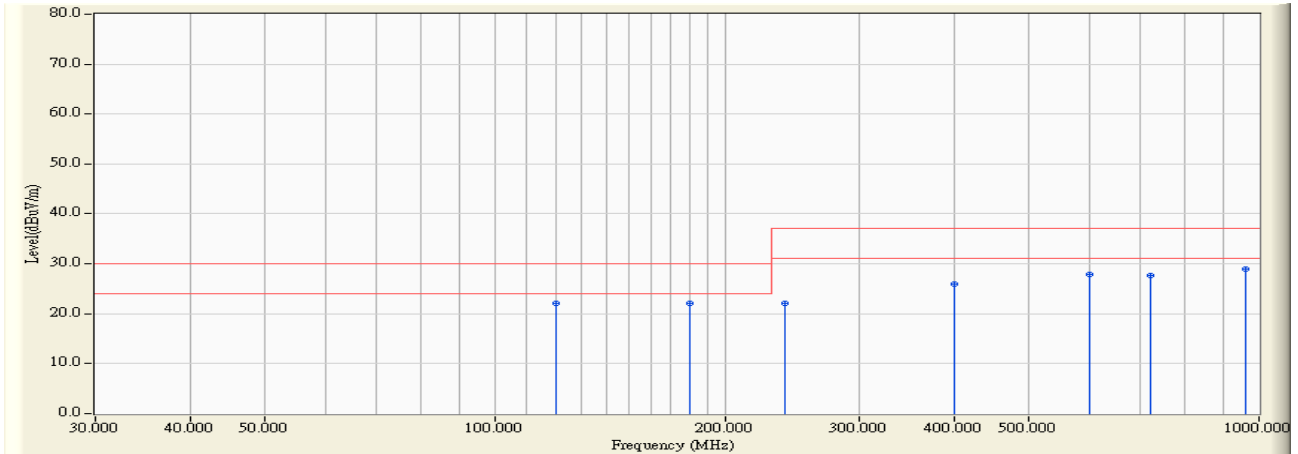

		Frequency (MHz)	Correct Factor (dB)	Reading Level (dBuV)	Measure Level (dBuV/m)	Margin (dB)	Limit (dBuV/m)	Detector Type
1		120.000	14.686	7.300	21.986	-8.014	30.000	QUASPEAK
2	*	180.000	12.200	9.900	22.101	-7.899	30.000	QUASPEAK
3		240.000	14.914	7.200	22.114	-14.886	37.000	QUASPEAK
4		400.000	20.599	5.300	25.899	-11.101	37.000	QUASPEAK
5		600.000	24.800	3.100	27.900	-9.100	37.000	QUASPEAK
6		720.000	25.837	1.900	27.737	-9.263	37.000	QUASPEAK
7		960.000	28.818	0.100	28.918	-8.082	37.000	QUASPEAK

Note:

1. All Readings below 1GHz are Quasi-Peak, above are performed with peak and/or average measurements as necessary.
2. " * ", means this data is the worst emission level.
3. Measurement Level = Reading Level + Correct Factor

Site : Site2	Time : 2014/04/28 - 14:28
Limit : CISPR_B_10M_QP	Margin : 6
EUT : M.2 SSD	Probe : Site2_CBL6112_10M_2705 - VERTICAL
Power : AC 120V/60Hz	Note : Mode 1

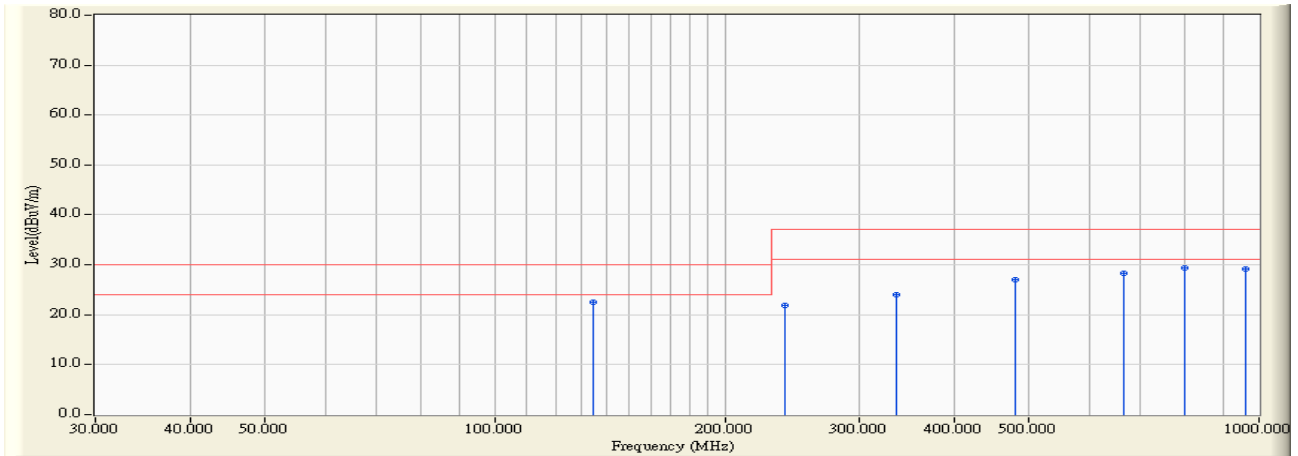

		Frequency (MHz)	Correct Factor (dB)	Reading Level (dBuV)	Measure Level (dBuV/m)	Margin (dB)	Limit (dBuV/m)	Detector Type
1	*	134.220	14.147	8.300	22.448	-7.552	30.000	QUASIPeAK
2		240.000	14.914	7.000	21.914	-15.086	37.000	QUASIPeAK
3		336.000	18.389	5.600	23.989	-13.011	37.000	QUASIPeAK
4		480.000	22.617	4.400	27.018	-9.982	37.000	QUASIPeAK
5		664.510	25.261	3.000	28.261	-8.739	37.000	QUASIPeAK
6		800.020	27.098	2.200	29.298	-7.702	37.000	QUASIPeAK
7		960.000	28.818	0.300	29.118	-7.882	37.000	QUASIPeAK

Note:

1. All Readings below 1GHz are Quasi-Peak, above are performed with peak and/or average measurements as necessary.
2. " * ", means this data is the worst emission level.
3. Measurement Level = Reading Level + Correct Factor

Site: CB7	Time: 2014/04/28 - 19:31
Limit: FCC_B_(Above_1G)	Margin: 0
Probe: CB7_Horn_9120D_1311	Polarity: Horizontal
EUT: M.2 SSD	Power: AC 120V/60Hz
Note: Mode 1	

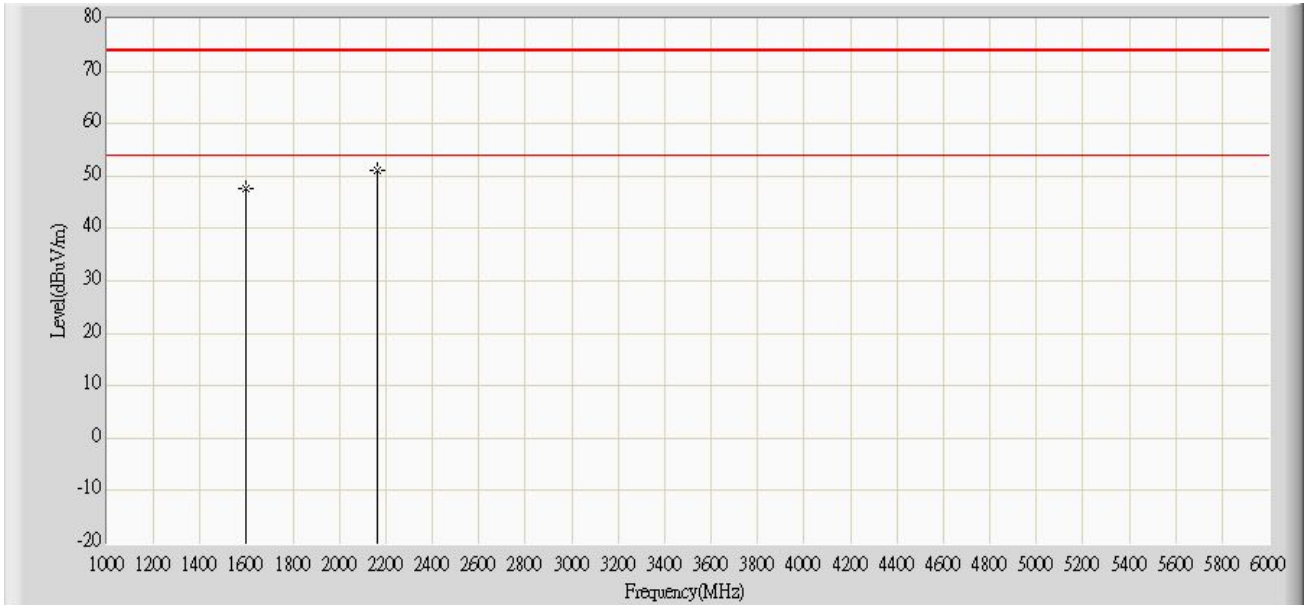

		Frequency (MHz)	Measure Level (dBuV/m)	Reading Level (dBuV)	Over Limit (dB)	Limit (dBuV/m)	Factor	Type
1		1600.000	47.735	50.370	-26.265	74.000	-2.635	PK
2	*	2166.000	51.094	51.160	-22.906	74.000	-0.067	PK

Note:

1. All Readings below 1GHz are Quasi-Peak, above are performed with peak and/or average measurements as necessary.
2. " * ", means this data is the worst emission level.
3. Measurement Level = Reading Level + Factor(Probe+Cable-Amp).

Site: CB7	Time: 2014/04/28 - 19:32
Limit: FCC_B_(Above_1G)	Margin: 0
Probe: CB7_Horn_9120D_1311	Polarity: Vertical
EUT: M.2 SSD	Power: AC 120V/60Hz
Note: Mode 1	

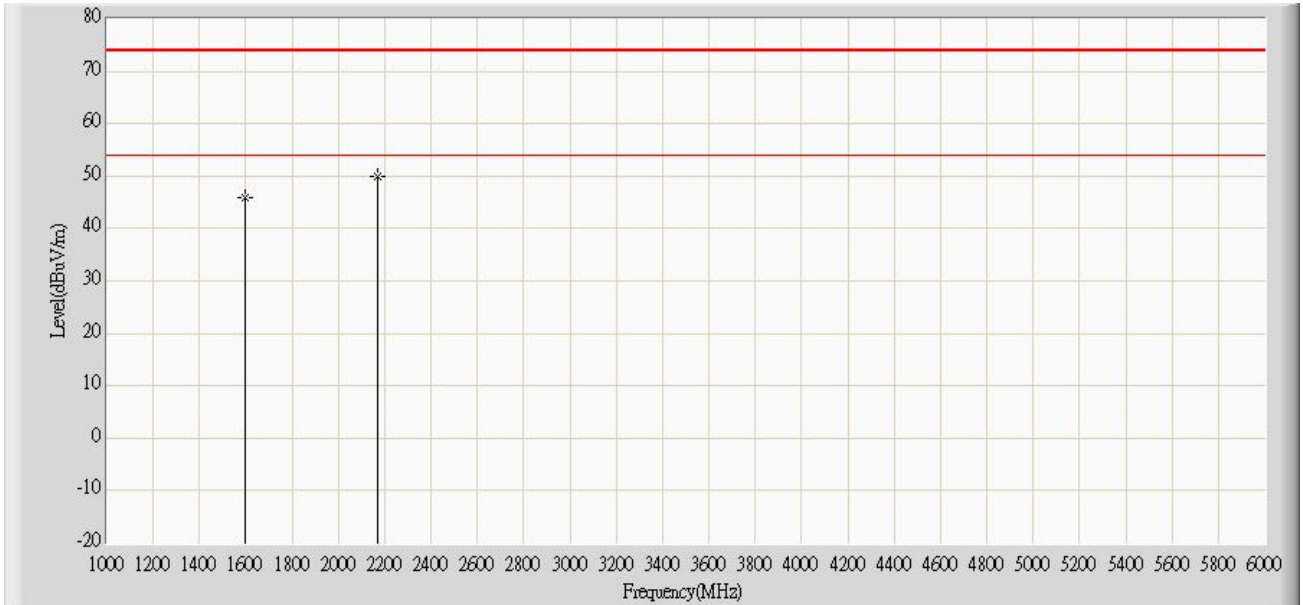

		Frequency (MHz)	Measure Level (dBuV/m)	Reading Level (dBuV)	Over Limit (dB)	Limit (dBuV/m)	Factor	Type
1		1600.000	45.875	48.510	-28.125	74.000	-2.635	PK
2	*	2170.000	49.809	49.890	-24.191	74.000	-0.081	PK

Note:

1. All Readings below 1GHz are Quasi-Peak, above are performed with peak and/or average measurements as necessary.
2. " * ", means this data is the worst emission level.
3. Measurement Level = Reading Level + Factor(Probe+Cable-Amp).

4.6. Test Photograph

Test Mode : Mode 1: Normal Operation

Description : Front View of Radiated Test



Test Mode : Mode 1: Normal Operation

Description : Back View of Radiated Test



Test Mode : Mode 1: Normal Operation

Description : Front View of High Frequency Radiated Test



5. Attachment

➤ EUT Photograph

(1) EUT Photo



(2) EUT Photo

