



CE TEST REPORT

FOR

SATA Flash Drive

**Model: SM220-297 128GB 256Gb*4 NO DEVSLP
w/Thermal Sensor+30 u Conn.**

Trade Name: Apacer

Issued to

Apacer Technology Inc.

**1F., No.32, Zhongcheng Rd., Tucheng Dist., New Taipei City 236, Taiwan
(R.O.C)**

Issued by

WH Technology Corp.

| | | |
|--|-----------------------------|---|
| Open Site | | No.120, Ln. 5, Hudong St., Xizhi Dist., New Taipei City 221, Taiwan (R.O.C.) |
| EMC Test Site | Xizhi Office and Lab | 7F., No.262, Sec. 3, Datong Rd., Xizhi Dist., New Taipei City 221, Taiwan (R.O.C.) |
| Tel.: +886-2-7729-7707 Fax: +886-2- 8648-1311 | | |

Note: This test refers exclusively to the test presented test model and sample. This report shall not be reproduced except in full, without the written approval of WH Technology Corp. This document may be altered or revised by WH Technology Corp. Personnel only, and shall be noted in the revision section of the document.



| | |
|---|-----------|
| TABLE OF CONTENTS | 2 |
| 1. GENERAL INFORMATION | 4 |
| 1.1 DESCRIPTION OF THE TESTED SAMPLES | 5 |
| 1.2 SUMMARY OF TEST RESULT | 6 |
| 1.3 TEST METHODOLOGY | 7 |
| 1.4 DESCRIPTION OF THE SUPPORT EQUIPMENTS | 8 |
| 1.5 FEATURES OF EUT:PLEASE REFER TO USER MANUAL OR PRODUCT SPECIFICATION. | 8 |
| 2. INSTRUMENT AND CALIBRATION | 9 |
| 2.1 MEASURING INSTRUMENT CALIBRATION | 9 |
| 2.2 TEST AND MEASUREMENT EQUIPMENT | 9 |
| 2.3 TEST PERFORMED | 10 |
| 2.4 APPENDIX | 11 |
| 3. CONDUCTED EMISSION MEASUREMENT | 13 |
| 3.1 TEST SET-UP | 13 |
| 3.2 LIMIT | 13 |
| 3.3 TEST PROCEDURE | 13 |
| 3.4 TEST SPECIFICATION | 14 |
| 3.5 RESULT: PASSED | 14 |
| 3.6 TEST DATA: | 14 |
| 4. RADIATED EMISSION MEASUREMENT | 15 |
| 4.1 TEST SETUP | 15 |
| 4.2 LIMIT | 16 |
| 4.3 TEST PROCEDURE | 16 |
| 4.4 TEST SPECIFICATION | 17 |
| 4.5 RESULT: PASSED | 17 |
| 4.6 TEST DATA: | 17 |
| PLEASE REFER TO APPENDIX 2 | 17 |
| 5. POWER HARMONIC MEASUREMENT | 18 |
| 5.1 TEST SETUP | 18 |
| 5.2 LIMIT OF HARMONIC CURRENT | 18 |
| 5.3 TEST PROCEDURE | 18 |
| 5.4 TEST SPECIFICATION | 18 |
| 5.5 RESULT: PASSED | 18 |
| 5.6 TEST DATA: | 18 |
| 6. VOLTAGE FLUCTUATIONS | 19 |
| 6.1 TEST SETUP | 19 |
| 6.2 VOLTAGE FLUCTUATIONS TEST | 19 |
| 6.3 TEST PROCEDURE | 19 |
| 6.4 TEST SPECIFICATION | 19 |
| 6.5 RESULT: PASSED | 19 |
| 6.6 TEST DATA: | 19 |
| 7. ELECTROSTATIC DISCHARGE IMMUNITY TEST (ESD) | 20 |
| 7.1 TEST PROCEDURE | 20 |
| 7.2 TEST SETUP | 20 |
| 7.3 TEST LEVEL | 20 |
| 7.4 TEST RESULT. | 21 |



| | | |
|-------------------------------------|---|-----------|
| 8. | RADIATED SUSCEPTIBILITY MEASUREMENT (RS) | 24 |
| 8.1 | TEST SETUP | 24 |
| 8.2 | TEST PROCEDURE | 24 |
| 8.3 | TEST LEVEL | 24 |
| 8.4 | TEST PROCEDURE | 25 |
| 8.5 | TEST RESULT | 25 |
| 9. | ELECTRICAL FAST TRANSIENT/BURST (EFT) | 27 |
| 9.1 | TEST SETUP | 27 |
| 9.2 | TEST PROCEDURE | 27 |
| 9.3 | TEST PROCEDURE | 27 |
| 9.4 | TEST LEVEL | 28 |
| 9.5 | TEST RESULT | 28 |
| 10. | SURGE | 29 |
| 10.1 | TEST SETUP | 29 |
| 10.2 | TEST PROCEDURE | 29 |
| 10.3 | TEST LEVEL | 29 |
| 10.4 | TEST PROCEDURE | 30 |
| 10.5 | TEST RESULT | 30 |
| 11. | IMMUNITY TEST TO CS CONDUCTED DISTURBANCE (CS) | 31 |
| 11.1 | TEST SETUP | 31 |
| 11.2 | TEST PROCEDURE | 31 |
| 11.3 | TEST LEVEL | 31 |
| 11.4 | TEST PROCEDURE | 32 |
| 11.5 | TEST RESULT | 32 |
| 12. | POWER FREQUENCY MAGNETIC FIELD (MAGNETIC) | 34 |
| 12.1 | TEST SETUP | 34 |
| 12.2 | TEST STANDARD | 34 |
| 12.3 | TEST LEVEL | 34 |
| 12.4 | TEST PROCEDURE | 34 |
| 12.5 | TEST RESULT | 35 |
| 13. | VOLTAGE DIPS AND INTERRUPTION MEASUREMENT | 36 |
| 13.1 | TEST SETUP | 36 |
| 13.2 | TEST PROCEDURE | 36 |
| 13.3 | TEST LEVEL | 37 |
| 13.4 | TEST PROCEDURE | 37 |
| 13.5 | TEST RESULT | 38 |
| 14. | PERFORMANCE CRITERIA | 39 |
| 15. | MEASUREMENT UNCERTAINTY | 40 |
| APPENDIX 1 | | |
| PHOTOS OF TEST CONFIGURATION | | |
| APPENDIX 2 | | |
| TEST DATA | | |
| APPENDIX 3 | | |
| PHOTOS OF EUT | | |



1. GENERAL INFORMATION

Applicant : Apacer Technology Inc.
Address : 1F., No.32, Zhongcheng Rd., Tucheng Dist., New Taipei City 236, Taiwan (R.O.C)
Manufacturer : Apacer Technology Inc.
Address : 1F., No.32, Zhongcheng Rd., Tucheng Dist., New Taipei City 236, Taiwan (R.O.C)
EUT : SATA Flash Drive
Model Name : SM220-297 128GB 256Gb*4 NO DEVSLP w/Thermal Sensor+30 u Conn.
Model Differences : N/A

Measurement procedure used:

EMI :

EN 55032: 2012+AC: 2013

EN 55022:2010+AC:2011

EN61000-3-2:2014

EN 61000-3-3:2013

AS/NZS CISPR 22:2009/A1:2010

EMS:

EN55024: 2010

IEC 61000-4-2 : 2008

IEC 61000-4-3 : 2006+A1: 2007+A2:2010

IEC61000-4-4: 2012

IEC 61000-4-5 : 2005

IEC 61000-4-6 : 2013

IEC 61000-4-8 : 2009

IEC 61000-4-11 : 2004

Deviation from Applicable Standard

According to the applicant's declaration this EUT is a class B product

The above equipment was tested by WH Technology Corp. for compliance with EMC requirements set forth in the EUROPEAN COUNCIL DIRECTIVE 2014/30/EU and the technical standards mentioned above. The results of testing in this report apply only to the product/system, which was tested. Other similar equipment will not necessarily produce the same results due to production tolerance.

This test report shall not be reproducing in part without written approval of WH Technology Corp.

Tested By:

Reviewed by:

Aug.30 , 2016

Date

Bell Wei/ Engineer

Aug.30 , 2016

Date

Mike Lee / Manager



1.1 DESCRIPTION OF THE TESTED SAMPLES

EUT

EUT Type : Engineer Type

Condition when received : Good Damage :

EUT Name : SATA Flash Drive

Model Number : SM220-297 128GB 256Gb*4 NO DEVSLP
w/Thermal Sensor+30 u Conn.

Receipt Date : 08/16/2016

EUT Power Rating : AC Power
 DC Power
 DCV from PC
 DCV from Adaptor

I/O Port of EUT : N/A



1.2 SUMMARY OF TEST RESULT

| Emission | | | | |
|----------------------|-------------------------------|-----------------------------|------------------------------|--------------------|
| Test Standard | Test Item | Test Result | | |
| EN55022 Class B | Conducted Emission | Pass | | |
| EN55022 Class B | Radiated Emission | Pass | | |
| EN61000-3-2 | Harmonic | Pass | | |
| EN61000-3-3 | Flicker | Pass | | |
| Immunity | | | | |
| Test Standard | Test Item | Performance Criteria | Observed Result Class | Test Result |
| IEC61000-4-2 | Electrostatic Discharge | B | A | Pass |
| IEC61000-4-3 | Radiated Susceptibility | A | A | Pass |
| IEC61000-4-4 | Electrical Fast Transient | B | A | Pass |
| IEC61000-4-5 | Surge | B | A | Pass |
| IEC61000-4-6 | Conducted Susceptibility | A | A | Pass |
| IEC61000-4-8 | Magnetic Field | A | A | Pass |
| IEC61000-4-11 | Voltage Dips and Interruption | Dips >95% B | B | Pass |
| | | Dips 30% C | C | Pass |
| | | Interruptions >95% C | C | Pass |



1.3 TEST METHODOLOGY
EUT SYSTEM OPERATION

1. The EUT was configured according to EN55022 CLASS B.
2. Photos of test configuration please refer to appendix 1.
3. Perform the EMC testing procedures, and measure the maximum emission noise.



1.4 DESCRIPTION OF THE SUPPORT EQUIPMENTS

Setup Diagram

See test photographs attached in appendix 1 for the actual connections between EUT and support equipment.

Support Equipment

Peripherals Devices:

| OUTSIDE SUPPORT EQUIPMENT | | | | | | | |
|---------------------------|-----------|----------|--|--------------------|------------|------------------------|--------------------|
| No. | Equipment | Model | Serial No. | FCC ID/ BSMI ID | Trade name | Data Cable | Power Cord |
| 1. | PC | D19M | CYY7Y A00 DC4 | R33002 | DELL | N/A | Unshielded 1.8m |
| 2. | Monitor | UZ2315Hf | CN-0NJ1C5-7 2872-473-AF2 SREVA02 | R43002 | DELL | Shielded 1.8m | Unshielded 1.8m |
| 3. | Printer | C9079A | TH6BG16249 | R33001 | HP | Shielded 1.8m / USB | Unshielded 1.8m |
| 4. | USB Flash | 8G | 1423146A016N ARG01S | D32210 | TOSHIBA | Shielded 1m / USB | N/A |
| 5. | Mouse | SM-2022 | 672652-001 | T3A062 | HP | Shielded 1.8m / USB | N/A |
| 6. | Keyboard | KB-1156 | 672646-AB3 TW | D33001 | HP | Shielded 1.6m / PS2 | N/A |

Note: All the above equipment /cable were placed in worse case position to maximize emission signals during emission test.

Grounding: Grounding was in accordance with the manufacturer's requirement and conditions for the intended use.

1.5 FEATURES OF EUT:

PLEASE REFER TO USER MANUAL OR PRODUCT SPECIFICATION.



2. INSTRUMENT AND CALIBRATION

2.1 MEASURING INSTRUMENT CALIBRATION

The measuring equipment utilized to perform the tests documented in the report has been calibrated once a year or in accordance with the manufacturer's recommendations, and is traceable to recognized national standards.

2.2 TEST AND MEASUREMENT EQUIPMENT

The following list contains measurement equipment used for testing. The equipment conforms to the requirement of CISPR 16-1, ANSI C63.2 and. Other required standards.

Calibration of all test and measurement, including any accessories that may effect such calibration, is checked frequently to ensure the accuracy. Adjustments are made and correction factors are applied in accordance with the instructions contained in the respective.

TABLELIST OF TEST AND MEASUREMENT EQUIPMENT

| Test Site | Instrument | Manufacturer | Model No. | S/N | Next Cal. Date |
|------------|--|-----------------------------------|--------------------|--------------------------|----------------|
| Conduction | Spectrum (9K--3GHz) | R&S | FSP3 | 833387/010 | 2016/09/22 |
| | EMI Receiver | R&S | ESHS10 | 830223/008 | 2017/05/22 |
| | LISN | Rolf Heine Hochfrequenztechnik | NNB-2/16z | 98062 | 2017/05/25 |
| | ISN | Schwarzbeck | 8-Wire ISN CAT5 | CAT5-8158-0 094 | 2016/09/23 |
| | RF Cable | N/A | N/A | EMI-3 | 2016/10/20 |
| | Click Analyzer | Schaffner | DIA1512C | 5218 | Jun 15, 2017 |
| Radiation | Bilog antenna(30M-1G) | ETC | MCTD2786B | BLB16M0400 4/JB-5-004 | 2017/05/03 |
| | Double Ridged Guide Horn antenna(1G-18G) | ETC | MCTD 1209 | DRH15N0 2009 | 2016/11/18 |
| | Horn antenna (18G-26G) | com-power | AH-826 | 81000 | 2016/08/25 |
| | Pre amplifier (30M-1G) | EMC INSTRUMENT | EMC9135 | 980334 | 2017/05/04 |



| | | | | | |
|-----|---------------------------------|--------------------|------------------------------------|------------------|---------------|
| | Microwave Preamplifier (1G-18G) | EMC INSTRUMENT | EMC051845 | 980108&AT -18001 | 2016/10/22 |
| | Pre amplifier (18G~26G) | MITEQ | JS4-180026 00-30-5A | 808329 | 2016/08/18 |
| | EMI Test Receiver | R&S | ESVS30 (20M-1000M Hz) | 863342/012 | 2016/10/22 |
| | RF Cable (open site) | EMCI | N male on end of both sides (EMI4) | 30m | 2016/10/21 |
| | RF CABLE (1~26.5G) | HARBOUT INDUSTRIES | LL142MI(4M+4M) | NA | 2017/03/08 |
| | RF CABLE (1~26.5G) | HARBOUR INDUSTRIES | LL142MI(7M) | NA | 2016/08/20 |
| | Spectrum (9K--7GHz) | R&S | FSP7 | 830180/006 | 2017/02/25 |
| | Spectrum (9K--40GHz) | AGILENT | 8564EC | 4046A0032 | 2017/01/03 |
| EMS | Harmonic/ Flicker | EMC-PARTNER | HAR-1000 | 066 | Sep. 27, 2016 |
| | ESD Simulator | NOISEKEN | ESS-2002 | ESS0767151 | Mar. 18. 2017 |
| | EFT Noise Generator | EMC-PARTNER | TRANSIENT -2000 | N/A | Sep. 03, 2016 |
| | Surge Tester | EMC-PARTNET | TRANSIENT -2000 | N/A | Mar. 17, 2017 |
| | CDN | FRANKONIA | CDN M2+M3 | A3011021 | Nov. 23, 2016 |
| | T4 CDN | FRANKONIA | CDN-RJ45 | A3023011 | Nov. 17, 2016 |
| | Conducted Immunity Test System | FRANKONIA | CIT-10175 | 102C3117 | Nov. 23, 2016 |

#: CALIBRATION INTERVAL OF INSTRUMENTS LISTED ABOVE IS ONE YEAR

2.3 TEST PERFORMED

Conducted emissions were investigated over the frequency range from 0.15 MHz to 30 MHz using a receiver which resolution bandwidth is set at 9 KHz.

Radiated emissions were investigated over the frequency range from 30 MHz to 1000 MHz using a receiver which resolution bandwidth is set at 120 KHz. Radiated measurement was performed at distance that from an antenna to EUT is 10 meters.



2.4 APPENDIX

Appendix A: Measurement Procedure for Main Power Port Conducted Emissions

The measurements are performed in a WH lab room; The EUT was placed on non-conductive 1.0m x 1.5m table, which is 0.8 meters above an earth-grounded.

Power to the EUT was provided through the LISN which has the Impedance (50 ohm/50 uH) vs. Frequency Characteristic in accordance with the standard. Powers to the LISNs were filtered to eliminate ambient signal interference and these filters were bonded to the ground plane. Peripheral equipment required to provide a functional system (support equipment) for EUT testing was powered from the second LISN through a ganged, metal power outlet box which is bonded to the ground plane at the LISN.

If the EUT is supplied with a flexible power cord, the power cord length in excess of the distance separating the EUT from the LISN shall be folded back and forth at the center of the lead so as to form a bundle not exceeding 40cm in length. If the EUT is provided with a permanently coiled power cord, bundling of the cord is not required. If the EUT is supplied without a power cord, the EUT shall be connected to the LISN by a power cord of the type specified by the manufacturer which shall not be longer than 1 meter. The excess power cord shall be bundled as described above. If a non-flexible power cord is provided with the EUT, it shall be cut to the length necessary to attach the EUT to the LISN and shall not be bundled.

The interconnecting cables were arranged and moved to get the maximum measurement. Both the line of power cord, hot and neutral, was measured.

The highest emissions were analyzed in details by operating the spectrum analyzer in fixed tuned mode to determine the nature of the emissions and to provide information which could be useful in reducing their amplitude.

Appendix B: Test Procedure for Radiated Emissions

Preliminary Measurements in the Anechoic Chamber

The radiated emissions are initially measured in the anechoic chamber at a measurement distance of 3 meters. Desktop EUT are placed on a wooden stand 0.8 meter in height. The measurement antenna is 3 meters from the EUT. The test setup in anechoic chamber is the same as open site. The turntable rotated 360°C. The antenna height is 1m. The primary objective of the radiated measurements in the anechoic chamber is to identify the frequency spectrum in the absence of the electromagnetic environment existing on the open test site. The frequencies can then be pre-selected on the open test site to obtain the corresponding amplitude. The initial scan is made with the spectrum analyzer in automatic sweep mode. The spectrum peaks are then measured manually to determine the exact frequencies.



Measurements on the Open Site or Chamber

The radiated emissions test will then be repeated on the open site or chamber to measure the amplitudes accurately and without the multiple reflections existing in the shielded room. The EUT and support equipments are set up on the turntable. Desktop EUT are set up on a wooden stand 0.8 meter above the ground.

For the initial measurements, the receiving antenna is varied from 1-4 meter height and is changed in the vertical plane from vertical to horizontal polarization at each frequency. Both reading are recorded with the quasi-peak detector with 120 KHz bandwidth. For frequency between 30 MHz and 1000 MHz, the reading is recorded with peak detector or quasi-peak detector.

At the highest amplitudes observed, the EUT is rotated in the horizontal plane while changing the antenna polarization in the vertical plane to maximize the reading. The interconnecting cables were arranged and moved to get the maximum measurement. Once the maximum reading is obtained, the antenna elevation and polarization will be varied between specified limits to maximize the readings.



3. CONDUCTED EMISSION MEASUREMENT

3.1 TEST SET-UP

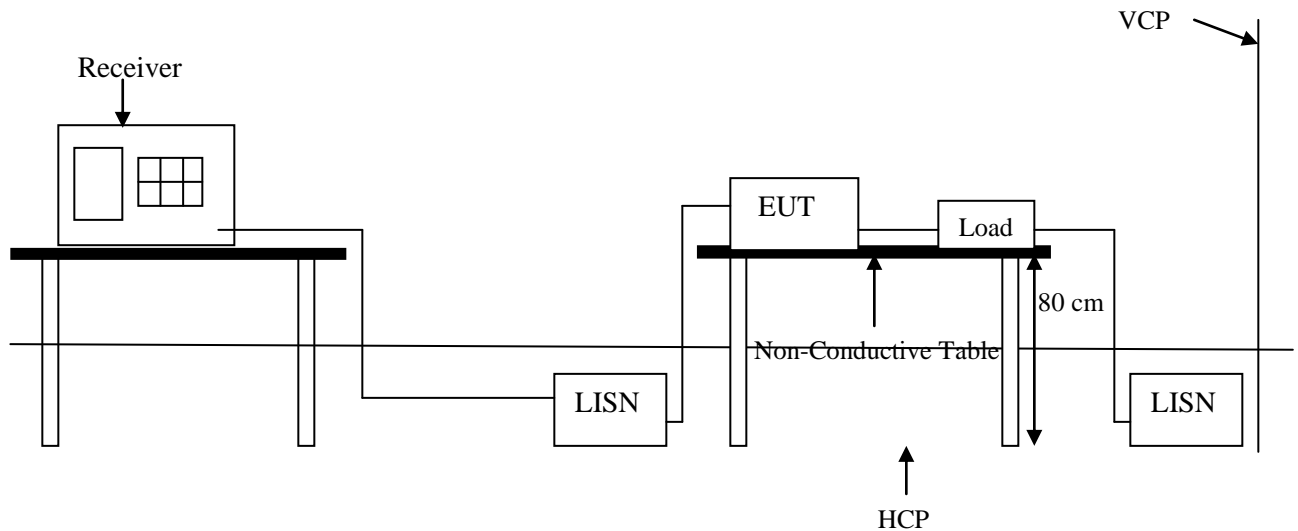

3.2 LIMIT

| Frequency range (MHz) | CLASS A | | CLASS B | |
|-----------------------|-----------|----------------|--------------|----------------|
| | QP dB(uV) | Average dB(uV) | QP dB(uV) | Average dB(uV) |
| 0.15-0.5 | 79 dBuV | 66 dBuV | 66 - 56 dBuV | 56 - 46 dBuV |
| 0.5-5.0 | 73 dBuV | 60 dBuV | 56 dBuV | 46 dBuV |
| 5.0-30.0 | 73 dBuV | 60 dBuV | 60 dBuV | 50 dBuV |

Remark: In the above table, the tighter limit applies at the band edges.

3.3 TEST PROCEDURE

The EUT and simulators are connected to the main power through a line impedance stabilization network (LISN). It provides a 50 ohm / 50 μ H coupling impedance for the measuring equipment. The peripheral devices are also connected to the main power through a LISN that provides a 50 ohm / 50 μ H coupling impedance with 50 ohm termination. (Please refer to the block diagram of the test setup and photograph.)

Both sides of AC line are checked for the maximum conducted emission interference. In order to find the maximum emissions, the relating positions of equipment and all of the interference cables must be changed according to EN 55022 regulation: The measurement procedure on conducted emission interference.

The resolution bandwidth of the field strength meter is set at 9 KHz



3.4 TEST SPECIFICATION

According to EN 55022

(Please refer to Page 4 for dated references which are related to the standard as mentioned above)

3.5 RESULT: PASSED

EMI Receiver/Spectrum Analyzer Configuration (for the frequencies tested)

| | |
|-----------------------|---------------------------|
| Frequency Range: | 150 KHz—30 MHz |
| Detector Function: | Quasi-Peak / Average Mode |
| Resolution Bandwidth: | 9 KHz |

3.6 TEST DATA:

Please refer to appendix 2



4. RADIATED EMISSION MEASUREMENT
4.1 TEST SETUP

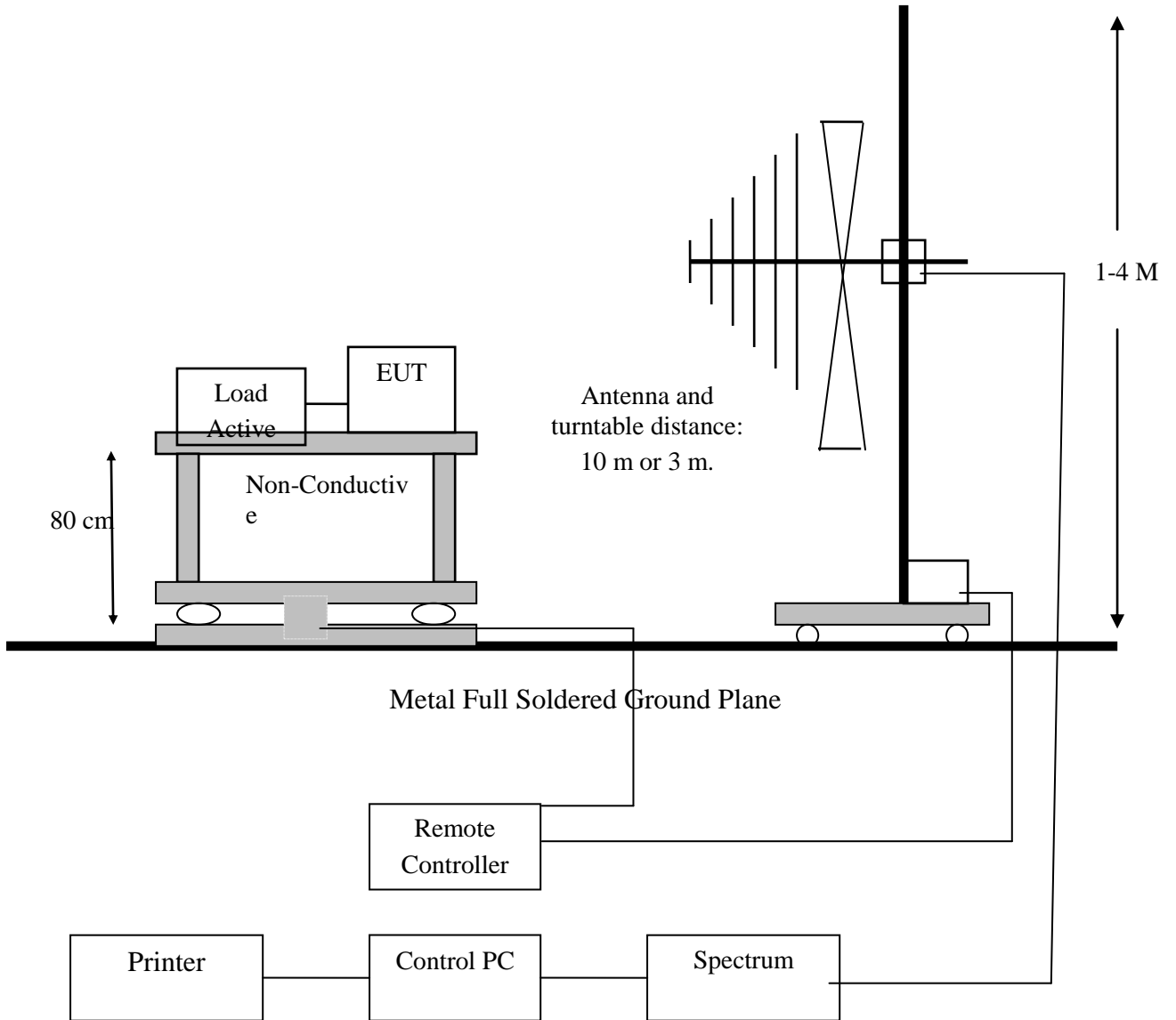



4.2 LIMIT

| Frequency | Class A | | Class B | |
|------------|------------------|--------------------|------------------|--------------------|
| MHz | Distance (Meter) | Limit dB μ V/m | Distance (Meter) | Limit dB μ V/m |
| 30 ~ 230 | 10 | 40 | 10 | 30 |
| 230 ~ 1000 | 10 | 47 | 10 | 37 |

For Class A

| Frequency range GHz | Average limit dB(μ V/m) | Peak limit dB(μ V/m) |
|---|------------------------------|---------------------------|
| 1 to 3 | 56 | 76 |
| 3 to 6 | 60 | 80 |
| NOTE The lower limit applies at the transition frequency. | | |

For Class B

| Frequency range GHz | Average limit dB(μ V/m) | Peak limit dB(μ V/m) |
|---|------------------------------|---------------------------|
| 1 to 3 | 50 | 70 |
| 3 to 6 | 54 | 74 |
| NOTE The lower limit applies at the transition frequency. | | |

Remark: In the above table, the tighter limit applies at the band edges.

4.3 TEST PROCEDURE

The EUT and its simulators are placed on turn table, non-conductive and wooden table, which is 0.8 meter above ground. The turn table rotates 360 degrees to determine the position of the maximum emission level. For the frequency range is below 1 GHz, the EUT was positioned such that distance from antenna to the EUT is 10 meters. For the frequency range is above 1 GHz, the EUT was positioned such that distance from antenna to the EUT is 3 meters.

For the frequency range is below 1 GHz, the antenna is moved up and down between 1 meter and 4 meters to receive the maximum emission level.

Both horizontal and vertical polarizations of the antenna are set on measurement. In order to find the maximum emission, all of the interference cables must be



manipulated according to EN55022 regulation: the test procedure of the radiated emission measurement.

The bandwidth set on the field strength is 120 KHz when the frequency range is below 1GHz. The bandwidth set on the field strength is 1 MHz when the frequency range is above 1GHz.

4.4 TEST SPECIFICATION

According to EN 55022 CLASS B

(Please refer to Page 4 for dated references which are related to the standard as mentioned above)

4.5 RESULT: PASSED

4.6 TEST DATA:

Please refer to appendix 2



5. POWER HARMONIC MEASUREMENT

5.1 TEST SETUP

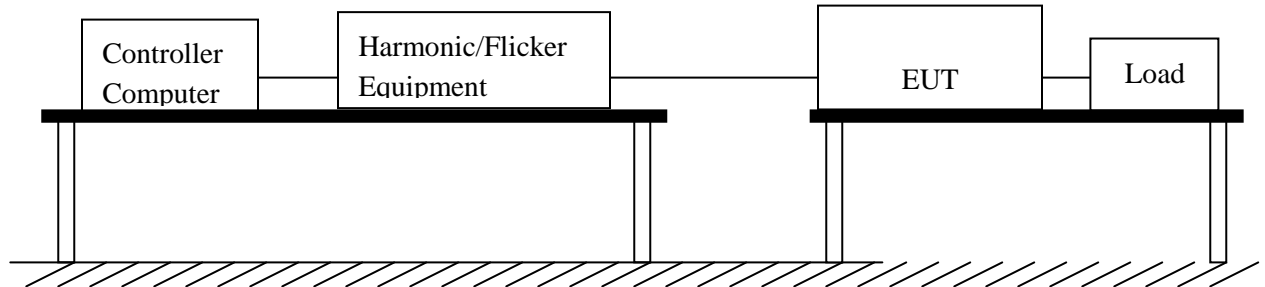

5.2 LIMIT OF HARMONIC CURRENT

Limit of Harmonic Currents

| Harmonic Order | Maximum Permissible Harmonic Current (Ampere) | Harmonic Order | Maximum Permissible Harmonic Current (Ampere) |
|----------------|---|----------------|---|
| Odd Harmonic | | Even Harmonic | |
| 3 | 2.30 | 2 | 1.08 |
| 5 | 1.14 | 4 | 0.43 |
| 7 | 0.77 | 6 | 0.30 |
| 9 | 0.40 | 8 ≤ n ≤ 40 | 0.23 x 8/n |
| 11 | 0.33 | | |
| 13 | 0.21 | | |
| 15 ≤ n (39) | 0.15 x 15/n | | |

5.3 TEST PROCEDURE

The EUT is supplied in series with power analyzer from a power source has the same normal voltage and frequency as the rated supply voltage and the equipment under test. The rated voltage at the supply voltage of EUT of 0.94 time and 1.06 times shall be performed.

5.4 TEST SPECIFICATION

According to EN 61000-3-2

(Please refer to Page 4 for dated references which are related to the standard as mentioned above)

5.5 RESULT: PASSED

5.6 TEST DATA:

Please refer to appendix 2



6. VOLTAGE FLUCTUATIONS

6.1 TEST SETUP

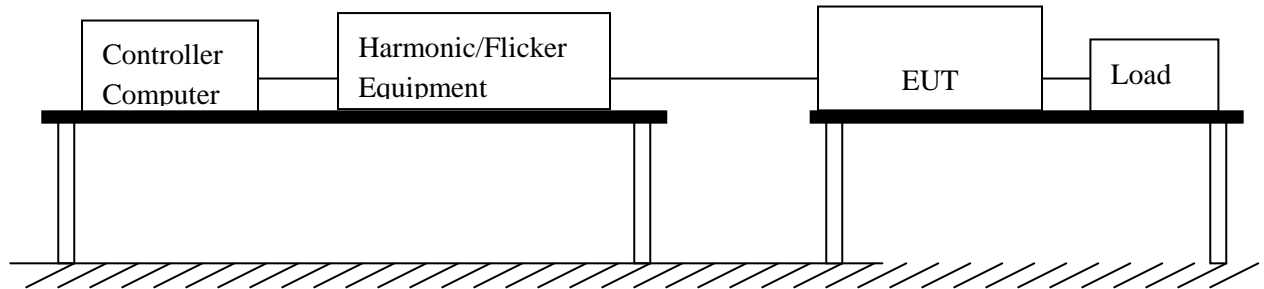

6.2 VOLTAGE FLUCTUATIONS TEST

| | |
|---------------------|------------------------|
| Port: | AC mains |
| Basic Standard: | EN61000-3-3 |
| Test Procedure | Refer to paragraph 6.3 |
| Observation period: | For Pst 10min |
| | For Plt 2 hours |

6.3 TEST PROCEDURE

The EUT is supplied in series with reference impedance from a power source with the voltage and frequency as the nominal supply voltage and frequency of the EUT.

6.4 TEST SPECIFICATION

According to EN 61000-3-3

According to EN55022 CLASS B

(Please refers to Page 4 for dated references which are related to the standard as mentioned above)

6.5 RESULT: PASSED

6.6 TEST DATA:

Please refer to appendix 2



7. ELECTROSTATIC DISCHARGE IMMUNITY TEST (ESD)

7.1 TEST PROCEDURE

According To IEC 61000-4-2

According To EN 55024

(Please refer to Page 4 for dated references which are related to the standard as mentioned above)

7.2 TEST SETUP

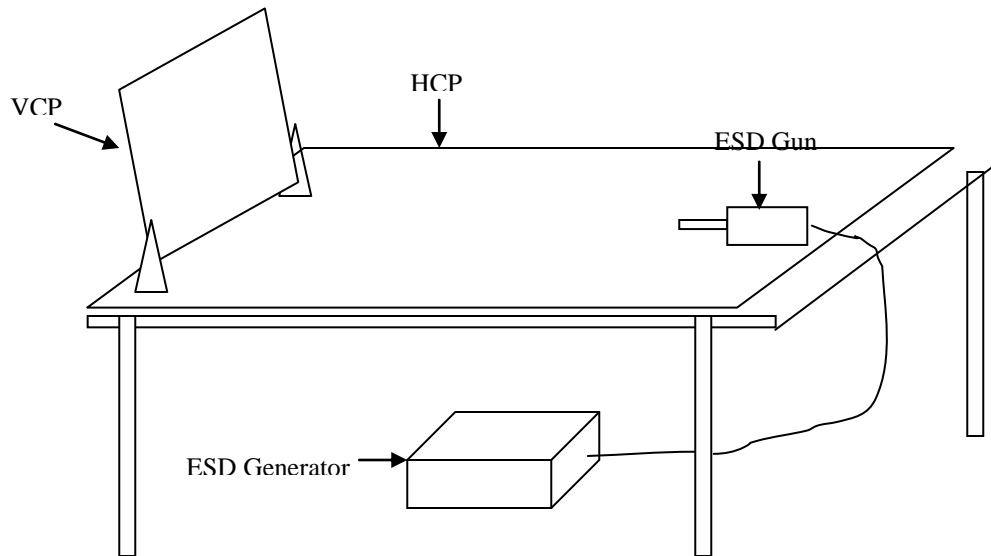

7.3 TEST LEVEL

| Item | Test Specification | Unit | Performance Criteria |
|--------------------------|--------------------------------|------------------------|----------------------|
| Enclosure Room | $\pm 2, 4, 8$ (Air Discharge) | KV (Charge Voltage) | B |
| Electrostatic Discharge | $\pm 2, 4$ (Contact Discharge) | | |
| Time between test | <u>1</u> | sec | |

Number of test: 10 Discharges / Test point / Polarity / Level

Particular requirements: at least 200 discharges, 100 each at negative and positive polarity, at a minimum of four test points.

When the measurement was taken, The ESD discharger was performed in single discharge. For the single discharge time between successive single discharges will keep on one second. It was at least ten single discharges with positive and negative at the same selected pointed. The selected pointed, which was performed with electrostatic discharge, was marked on the red label on the EUT Indirect applicant of discharge to the EUT

Vertical Coupling Plane (VCP)



The coupling plane, of dimensions 0.5 m x 0.5 m, is placed parallel to, and positioned at a distance 0.1 m from, the EUT, with the discharge electrode touching the coupling plane.

The four faces of the EUT will be performed with electrostatic discharge. It was at least ten singles discharges with positive and negative at the same selected point.

Horizontal Coupling Plane (HCP)

The coupling plane is placed under the EUT. The generator shall be positioned vertically at a distance of 0.1m from the EUT, with the discharge electrode touching the coupling.

The four faces of the EUT will be performed with electrostatic discharge. It was at least ten single discharges with positive and negative at the same selected pointed.

7.4 TEST RESULT.

Model:

SM220-297 128GB 256Gb*4 NO DEVSLP

w/Thermal Sensor+30 u Conn.

Temperature: 26 °C , Humidity: 41 % RH

| Test Item : Direct Discharge | | | | | | | | | | | | | | | | |
|---------------------------------------|-------------|-------------|-------------|-----------|-----------|-----------|-----------|----------------------|----------|-------------|----------|-------------|----------|-------------|----------|----------|
| Contact Discharge | | | | | | | | Air Discharge | | | | | | | | |
| 2 KV | | 4 KV | | KV | | KV | | 2 KV | | 4 KV | | 6 KV | | 8 KV | | |
| + | - | + | - | + | - | + | - | + | - | + | - | + | - | + | - | |
| A | A | A | A | / | / | / | / | A | A | A | A | A | A | A | A | |
| Test Item : Indirect Discharge | | | | | | | | | | | | | | | | |
| Contact Discharge | | | | | | | | | | | | | | | | |
| | 2 KV | | 4 KV | | KV | | KV | | | | | | | | | |
| | + | - | + | - | + | - | + | - | + | - | + | - | + | - | + | - |
| 1 | A | A | A | A | / | / | / | / | / | / | / | / | / | / | / | / |

Performance Criteria:

- A) Normal performance within the specification;
 - B) Temporary degradation or less of function of performance which is self recoverable;
 - C) Temporary degradation or less of function or perform. Which requires. operate intervention or system reset;
 - D) Degradation or loss of function which is not recoverable due to damage of equipment (components) or software, or loss of data;
- "/" : no test.



Test points please refer below photos.





Red dot: Contact; Blue dot: Air

Final Result: **PASSED**

Remark:

Photos of test configuration please refer to appendix 1.



8. RADIATED SUSCEPTIBILITY MEASUREMENT (RS)

8.1 TEST SETUP

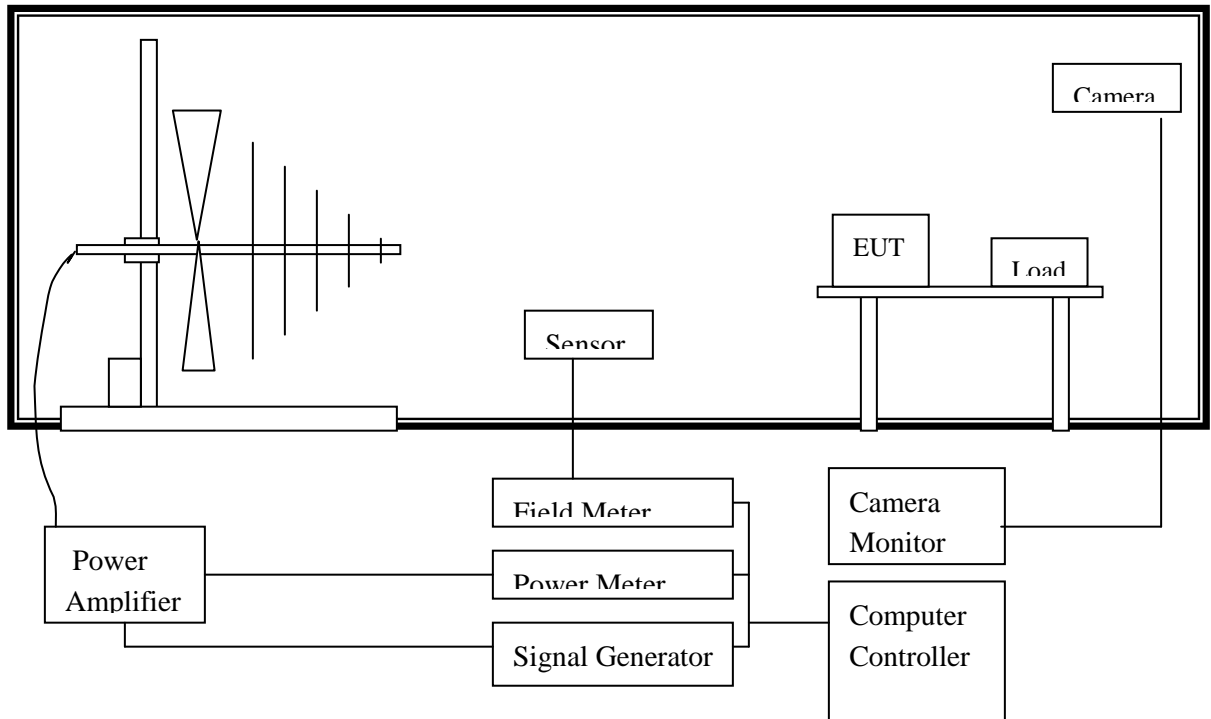

8.2 TEST PROCEDURE

According To IEC 61000-4-3

According To EN 55024

(Please refer to Page 4 for dated references which are related to the standard as mentioned above)

8.3 TEST LEVEL

| Item | Test Specification | Unit | Performance Criteria |
|-----------------------|--------------------|------------------------|----------------------|
| Radio –Frequency | 80~1000 | MHz | A |
| Electromagnetic Field | 3 | V/m (unmodulated, rms) | |
| Amplitude Modulated | 80 | %AM (1 KHz) | |



8.4 TEST PROCEDURE

The EUT and load, which are placed on a wooden table whose height is 0.8 meter aboveground, are placed with one coincident with the calibration plane such that the distance from antenna to the EUT is 3 meters.

Both horizontal and vertical polarization of the antenna position and four sides of the EUT are set on measurement. In order to judge the EUT performance, a CCD camera is used to monitor the situation of EUT.

All the scanning conditions are as follows:

| Condition of Test | Remarks |
|-------------------------------------|--------------------------------|
| 1. Field Strength | 3 V/m; Level 2 |
| 2. Radiated Signal | AM 80% modulated with 1 KHz |
| 3. Scanning Frequencies | 80 MHz ~ 1000 MHz |
| 4. Dwell Time | 3 seconds |
| 5. Frequency step size | 1% |
| 6. The rate of swept of frequency | 1.5×10^{-3} decades/s |
| 7. Antenna Polarity | HORIZONTAL & VERTICAL |
| 8. The four sides of EUT are tested | FRONT, REAR, RIGHT, LEFT |

8.5 TEST RESULT

Model:
SM220-297 128GB 256Gb*4 NO DEVSLP w/Thermal Sensor+30 u Conn.

Temperature: 26 °C , Humidity: 41 % RH

| ANT SIDE | 3 V HORIZONTAL | 3 V VERTICAL | RESULT |
|-------------|-------------------|-----------------|---------------|
| FRONT | A | A | PASSED |
| REAR | A | A | PASSED |
| RIGHT | A | A | PASSED |
| LEFT | A | A | PASSED |



Performance Criteria:

- A) Normal performance within the specification;
 - B) Temporary degradation or less of function of performance which is self recoverable;
 - C) Temporary degradation or less of function or perform. Which requires. operate intervention or system reset;
 - D) Degradation or loss of function which is not recoverable due to damage of equipment (components) or software, or loss of data;
- "/" : no test.

Final Result: **PASSED**

Remark:

Photos of test configuration please refer to appendix 1.



9. ELECTRICAL FAST TRANSIENT/BURST (EFT)

9.1 TEST SETUP

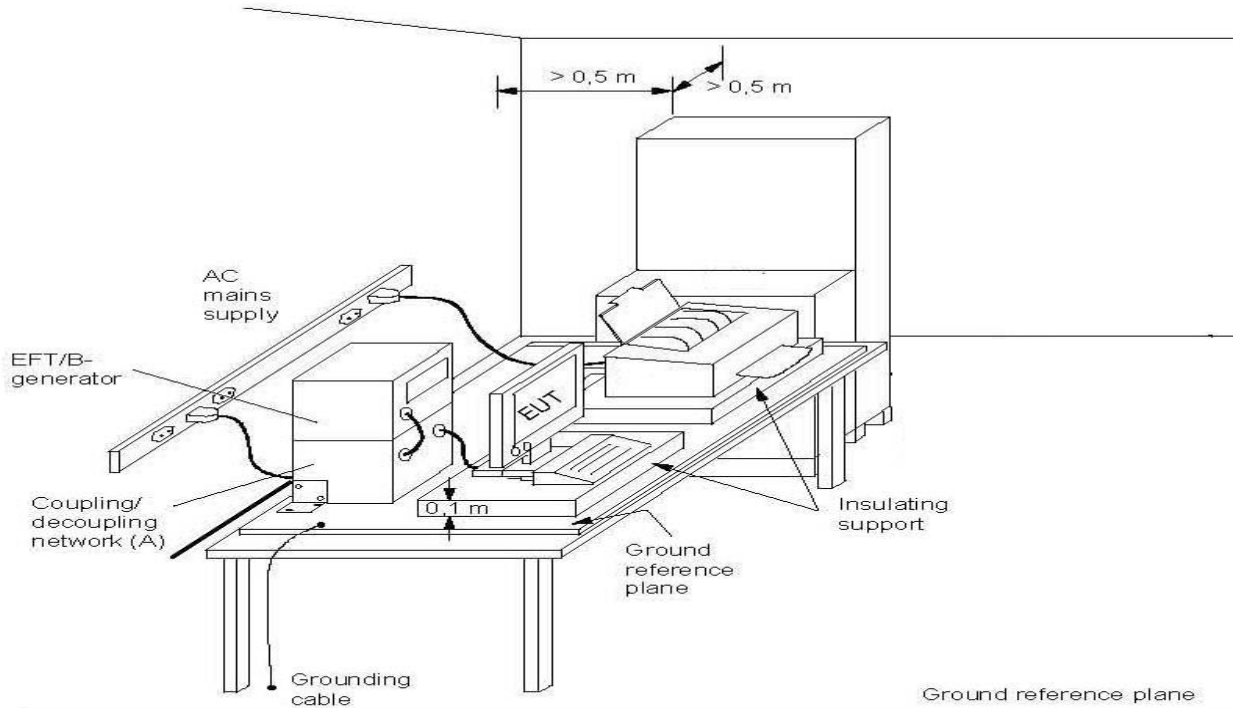

9.2 TEST PROCEDURE

According To IEC 61000-4-4

According To EN 55024

(Please refer to Page 4 for dated references which are related to the standard as mentioned above)

9.3 TEST PROCEDURE

The EUT and load are placed on a ground reference plane and insulated from it by an insulating support $0,1\text{ m} \pm 0,01\text{ m}$ thick. The minimum area of the ground reference plane is $1\text{ m} \times 1\text{ m}$. It also projected beyond the EUT by at least 0.1 meter on all sides.

For Input and Output AC power or DC Input and DC Output Power Ports:

The EUT is connected with the power mains through a coupling device that directly couples the EFT interference signal.

Each of the line and nature conductors is impressed with burst noise for 1 minute.

For Protective Earth Port:

The EUT is connected to the power mains through a coupling device that directly couples the EFT interference signal. The protective earth line (PE) is impressed with burst noise for 1 minute.

The length of power cord between the coupling device and the EUT shall be $0,5\text{ m} \pm 0,05\text{ m}$.

For signal Lines and Control Lines Test:



The EFT interference signal is through a coupling clamp device couples to the signal and control lines of the EUT with burst noise for 1 minute.

9.4 TEST LEVEL

| Item | Test Specification | Unit | Performance Criteria |
|----------------------------|--------------------|----------------------|----------------------|
| Test Voltage | ±0.5, ±1 | KV (Peak) | B |
| Pulse Rise time & Duration | 5/50 | Tr/Ts (ns) | |
| Pulse Repetition | 5 | Rep. Frequency (KHz) | |

9.5 TEST RESULT

Model:SM220-297 128GB 256Gb*4 NO DEVSLP w/Thermal Sensor+30 u Conn.

Temperature: 26 °C , Humidity: 41 % RH

| Test Point/ Mode / Result | | 0.5 KV | | 1 KV | | 2 KV | |
|---------------------------|---|--------|---|------|---|------|---|
| | | + | - | + | - | + | - |
| Power Line | L | A | A | A | A | A | A |
| | N | A | A | A | A | A | A |
| | G | A | A | A | A | A | A |
| Signal Line Clamp Test | | / | / | / | / | / | / |

Performance Criteria:

- A) Normal performance within the specification;
 - B) Temporary degradation or loss of function or performance which is self recoverable;
 - C) Temporary degradation or loss of function or perform. Which requires. operate intervention or system reset;
 - D) Degradation or loss of function which is not recoverable due to damage of equipment (components) or software, or loss of data;
- "/" : no test.

Final Result: **PASSED**

Remark:

Photos of test configuration please refer to appendix 1.



10. SURGE

10.1 TEST SETUP

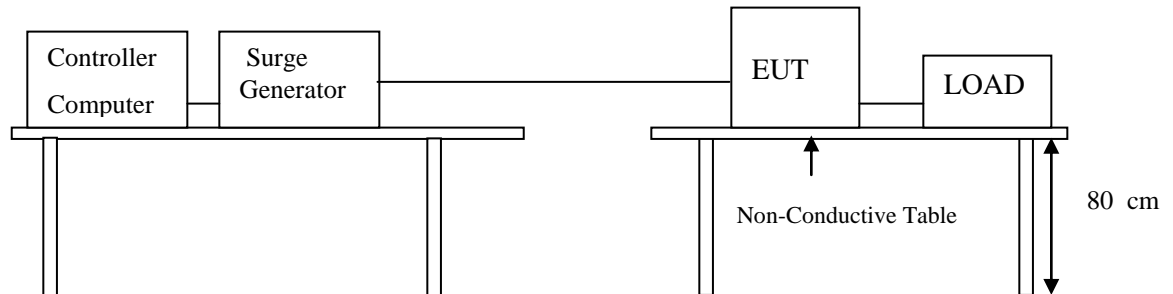

10.2 TEST PROCEDURE

According To IEC 61000-4-5

According To EN 55024

(Please refer to Page 4 for dated references which are related to the standard as mentioned above)

10.3 TEST LEVEL

| Item | Test Specification | Unit | Performance Criteria |
|---|---------------------|------------|----------------------|
| DC Input and DC Output Power Ports | | | |
| Surge | 1.2/50(8/20) | Tr/Ts (μs) | B |
| Line to Ground | ±0.5 | KV | |
| Line to Line | ±0.5 | KV | |
| AC Input and AC Output Power Ports | | | |
| Surge | 1.2/50(8/20) | Tr/Ts (μs) | B |
| Line to Ground | ±2 | KV | |
| Line to Line | ±1 | KV | |
| Polarity | POSITIVE / NEGATIVE | | |
| Phase shifting in a range between 0°to 360° | | | |



10.4 TEST PROCEDURE

The EUT and its load are placed on a table which is 0.8 meter height. The length of power cord between the coupling device and the EUT shall be 2 meters or less.

For Input and Output AC Power or DC Input and DC Output Power Ports:

The EUT is connected to the power mains through a coupling device that directly couples the Surge interference signal.

The Surge noise shall be applied synchronized to the voltage phase at 0°, 90°, 180°, 270° and the peak value of the AC voltage wave. (5 Positive and 5 Negative)

Each of line-earth and line-line is impressed with a sequence of five surge voltages with interval of 1 minute.

10.5 TEST RESULT

Model:SM220-297 128GB 256Gb*4 NO DEVSLP w/Thermal Sensor+30 u Conn.

Temperature: 26 °C , Humidity: 41 % RH

| Phase/Polarity/Mode/Result | | | 0 | 90 | 180 | 270 |
|----------------------------|---------|---|---|----|-----|-----|
| Signal Line 2 KV | Line | + | / | / | / | / |
| | Neutral | - | / | / | / | / |
| 1 KV | Line | + | A | A | A | A |
| | Neutral | - | A | A | A | A |
| 2 KV | Line | + | A | A | A | A |
| | Ground | - | A | A | A | A |
| | Neutral | + | A | A | A | A |
| | Ground | - | A | A | A | A |

Performance Criteria:

- A) Normal performance within the specification;
- B) Temporary degradation or less of function of performance which is self recoverable;
- C) Temporary degradation or less of function or perform. Which requires. operate intervention or system reset;
- D) Degradation or loss of function which is not recoverable due to damage of equipment (components) or software, or loss of data;

"/" : no test.

Final Result: **PASSED**

Remark:

Photos of test configuration please refer to appendix 1.



11. IMMUNITY TEST TO CS CONDUCTED DISTURBANCE (CS)

11.1 TEST SETUP

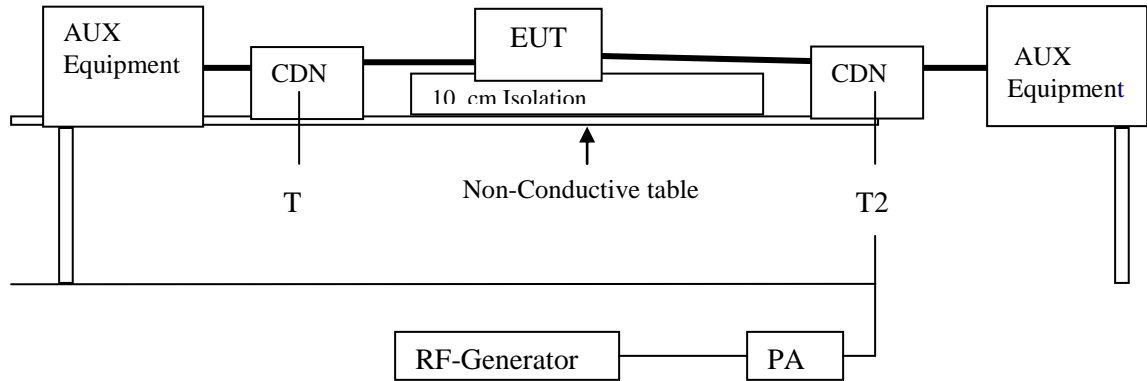

11.2 TEST PROCEDURE

According To IEC 61000-4-6

According To EN 55024

(Please refer to Page 4 for dated references which are related to the standard as mentioned above)

11.3 TEST LEVEL

| Item | Test Specification | Unit | Performance Criteria |
|--|--------------------|----------------------|----------------------|
| Ports for Signal Lines | | | |
| Radio-Frequency | 0.15 ~ 80 | MHz | A |
| Common Mode | 3 | V (rms, Unmodulated) | |
| Amplitude Modulated | 80 | %AM (1 KHz) | |
| | 150 | Source Impedance | |
| Ac Input and AC Output and DC Input and DC output Ports and Functional Earth Ports | | | |
| Radio-Frequency | 0.15 ~ 80 | MHz | |
| Common Mode | 3 | V (rms, Unmodulated) | A |
| Amplitude Modulated | 80 | %AM (1 KHz) | |
| | 150 | Source Impedance | |



11.4 TEST PROCEDURE

The EUT are placed on a table which is 0.8 meter height and a ground reference plane on the table, the EUT are placed upon table and use 10cm insulation between the EUT and ground reference plane.

For AC Input and AC Output Power or DC Input and DC Output Power Ports

The EUT is connected to the power mains through a coupling and decoupling networks for Power supply lines. It also directly couples the disturbance signal into EUT.

Use CDN-M2 for two wires or CDN-M3 for three wires.

For Signal Lines and Control Lines Test:

The disturbance signal is through a coupling and decoupling networks (CDN) or EM-clamp which is to couple the signal and control lines of the EUT.

All scanning frequencies conditions are as following:

| Condition of Test | Remarks |
|-----------------------------------|--------------------------------|
| IEC 61000-4-6 | |
| 1. Field Strength | 3 V; Level 2 |
| 2. Radiated Signal | AM 80% modulated with 1 KHz |
| 3. Scanning Frequencies | 0.15 MHz ~ 80 MHz |
| 4. Dwell Time | 3 seconds |
| 5. Frequency step size Δf | 1% |
| 6. The rate of swept of frequency | 1.5×10^{-3} decades/s |

11.5 TEST RESULT

Model:SM220-297 128GB 256Gb*4 NO DEVSLP w/Thermal Sensor+30 u Conn.

Temperature: 26 °C , Humidity: 41 % RH

| TEST Specification | Unit | Performance Criteria |
|--------------------|--------------|----------------------|
| 0.15 - 80 | MHz | A |
| 3 | V | |
| 80 | % AM (1 KHz) | |

Performance Criteria:

- A) Normal performance within the specification;
- B) Temporary degradation or less of function of performance which is self recoverable;
- C) Temporary degradation or less of function or perform. Which requires. operate intervention or system reset;
- D) Degradation or loss of function which is not recoverable due to damage of equipment (components) or software, or loss of data;

"/" : no test.



Final Result: **PASSED**

Remark:

Photos of test configuration please refer to appendix 1.



12. POWER FREQUENCY MAGNETIC FIELD (MAGNETIC)

12.1 TEST SETUP

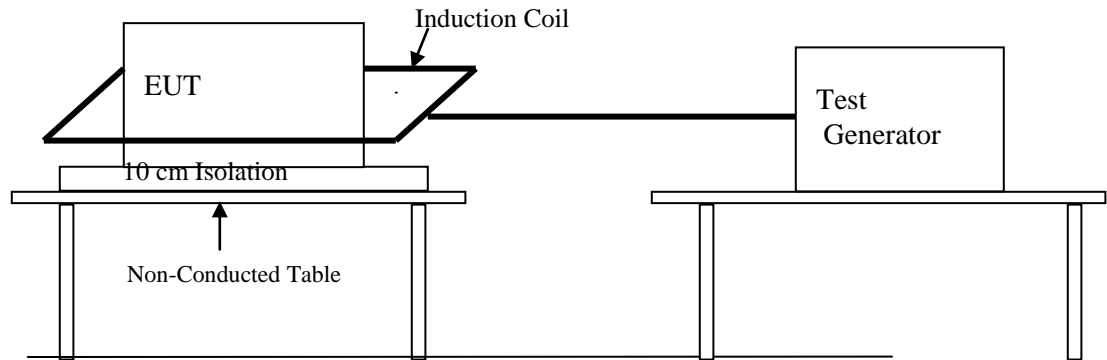

12.2 TEST STANDARD

According To IEC 61000-4-8

According To EN 55024

(Please refer to Page 4 for dated references which are related to the standard as mentioned above)

12.3 TEST LEVEL

| Item | Test Specification | Unit | Performance Criteria |
|-----------------|--------------------|------|----------------------|
| Power-Frequency | 50 | Hz | A |
| Magnetic Field | 1 | A/m | |

12.4 TEST PROCEDURE

The EUT and its load are placed on a table that is 0.8 meter above the metal ground plane dimension is at least 1 meter x 1 meter. The test magnetic field shall be placed at least than 3 meter distance from the induction coil.

The test magnetic field shall be applied by the immersion method to the EUT. The induction coil shall be rotated by 90° in order to expose the EUT to the test field with different orientation (X, Y, Z orientation).



12.5 TEST RESULT

Model:SM220-297 128GB 256Gb*4 NO DEVSLP w/Thermal Sensor+30 u Conn.

Temperature: 26 °C , Humidity: 41 % RH

| Environmental Phenomena | Test Specification | Units | Performance Criteria |
|-------------------------|--------------------|-------|----------------------|
| Magnetic Field | 1 | A/m | A |

Performance Criteria:

- A) Normal performance within the specification;
 - B) Temporary degradation or less of function of performance which is self recoverable;
 - C) Temporary degradation or less of function or perform. Which requires. operate intervention or system reset;
 - D) Degradation or loss of function which is not recoverable due to damage of equipment (components) or software, or loss of data;
- "/" : no test.

Final Result: **PASSED**

Remark:

Photos of test configuration please refer to appendix 1.



13. VOLTAGE DIPS AND INTERRUPTION MEASUREMENT

13.1 TEST SETUP

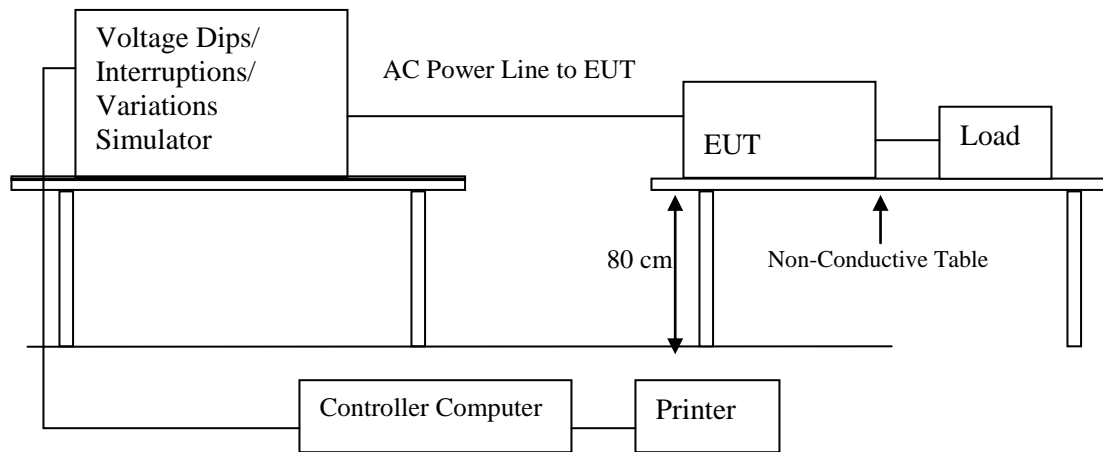

13.2 TEST PROCEDURE

According To IEC 61000-4-11

According To EN 55024

(Please refer to Page 4 for dated references which are related to the standard as mentioned above)



13.3 TEST LEVEL

| Class ^a | Test level and durations for voltage dips | | | | |
|----------------------|--|--------------------|---------------------------------------|---------------------------------------|---|
| Class 1 | Case-by-case according to the equipment requirements | | | | |
| Class 2 | 0 % during 1/2 cycle | 0 % during 1 cycle | 70 % during 25/30 ^c cycles | | |
| Class 3 | 0 % during 1/2 cycle | 0 % during 1 cycle | 40 % during 10/12 ^c cycles | 70 % during 25/30 ^c cycles | 80 % during 250/300 ^c cycles |
| Class X ^b | X | X | X | X | X |

a: Classes as per IEC 61000-2-4.
b: To be defined by product committee. For equipment connected directly or indirectly to the public network, the levels must not be less severe than Class 2.
c: "25/30 cycles" means "25 cycles for 50 Hz test" and "30 cycles for 60 Hz tet".

| Class ^a | Test level and durations for short interruptions (t _s) (50Hz / 60Hz) |
|----------------------|--|
| Class 1 | Case-by-case according to the equipment requirements |
| Class 2 | 0 % during 250/300 ^c cycles |
| Class 3 | 0 % during 250/300 ^c cycles |
| Class X ^b | X |

a: Classes as per IEC 61000-2-4.
b: To be defined by product committee. For equipment connected directly or indirectly to the public network, the levels must not be less severe than Class 2.
c: "250/300 cycles" means "250 cycles for 50 Hz test" and "300 cycles for 60 Hz test".

13.4 TEST PROCEDURE

The EUT and its load are placed on a wooden table which is 0.8 meter above a metal ground plane which dimension is 1 meter x 1 meter, the thickness is 0.65mm. It projected beyond the EUT by at least 0.1 meter on all sides. The power cord shall be used the shortest power cord as specified by the manufacturer.

For Voltage Dips / Interruption Test:

The EUT is connected to the power mains through a coupling device that directly couples to the Voltage Dips and Interruption Generator.

The EUT shall be tested for 30% voltage dips of supplied voltage and duration time is 10ms, for 60% voltage dips of supplied voltage and duration time is 100ms with a sequence of three voltage dips with intervals of 10 seconds, and for 95% voltage interruption of supplied voltage and the duration time is 5000ms with a sequence of three voltage interruptions with intervals of 10 seconds.

Voltage phase shifting are shall occur at 0°, 45°, 90°, 135°, 180°, 225°, 270°, 315° of the voltage.



13.5 TEST RESULT

Model:SM220-297 128GB 256Gb*4 NO DEVSLP w/Thermal Sensor+30 u Conn.

Temperature: 26 °C , Humidity: 41 % RH

| Voltage Dips | Test Level % U _T | Reduction (%) | Duration | Performance Criteria |
|--------------|--------------------------------|------------------|---------------|-------------------------|
| | <5 | >95 | 0.5 (periods) | B |
| | 70 | 30 | 25 (periods) | B |

| Voltage Dips | Test Level % U _T | Reduction (%) | Duration | Performance Criteria |
|--------------|--------------------------------|------------------|-----------------|-------------------------|
| | 70 | 30 | 10ms | C |
| | 40 | 60 | 100 and 1000 ms | C |

| Voltage Dips | Test Level % U _T | Reduction (%) | Duration | Performance Criteria |
|--------------|--------------------------------|------------------|-------------------------|-------------------------|
| | <5 | >95 | 250(periods) 5000 ms | C |

Performance Criteria:

- A) Normal performance within the specification;
 - B) Temporary degradation or less of function of performance which is self recoverable;
 - C) Temporary degradation or less of function or perform. Which requires. operate intervention or system reset;
 - D) Degradation or loss of function which is not recoverable due to damage of equipment (components) or software, or loss of data;
- "/" : no test.

Final Result: **PASSED**

Remark:

Please refer to appendix 1.



14. PERFORMANCE CRITERIA

- A. The apparatus shall continue to operate as intended during and after the test. No degradation of performance or loss of function is allowed below a performance level specified by the manufacturer, when the apparatus is used as intended.
- B. The apparatus shall continue to operate as intended after the test. No degradation of performance or loss of function is allowed below a performance level specified by the manufacturer, when the apparatus is used as intended. The performance level may be replaced by a permissible loss of performance. During the test, degradation of performance is however allowed.
- C. Temporary loss of function is allowed, provided the function is self-recoverable or can be restored by the operation of the controls.



15. MEASUREMENT UNCERTAINTY

| Measurement Item | Measurement Frequency | Polarization | Uncertainty |
|--------------------|-----------------------|--------------|-------------|
| Conducted Emission | 9 kHz ~ 30. MHz | LINE/NEUTRAL | 1.78 dB |
| Radiated Emission | 30 MHz ~ 1,000 MHz | Horizontal | 3.59 dB |
| | | Vertical | 3.89 dB |
| | 1,000 MHz ~ 18GHz | Horizontal | 5.00 dB |
| | 1,000 MHz ~ 18GHz | Vertical | 4.64 dB |



APPENDIX 1

PHOTOS OF TEST CONFIGURATION

Photograph – Conducted Emission Test Setup





Photograph – Radiated Emission Test Setup-Below 1GHz

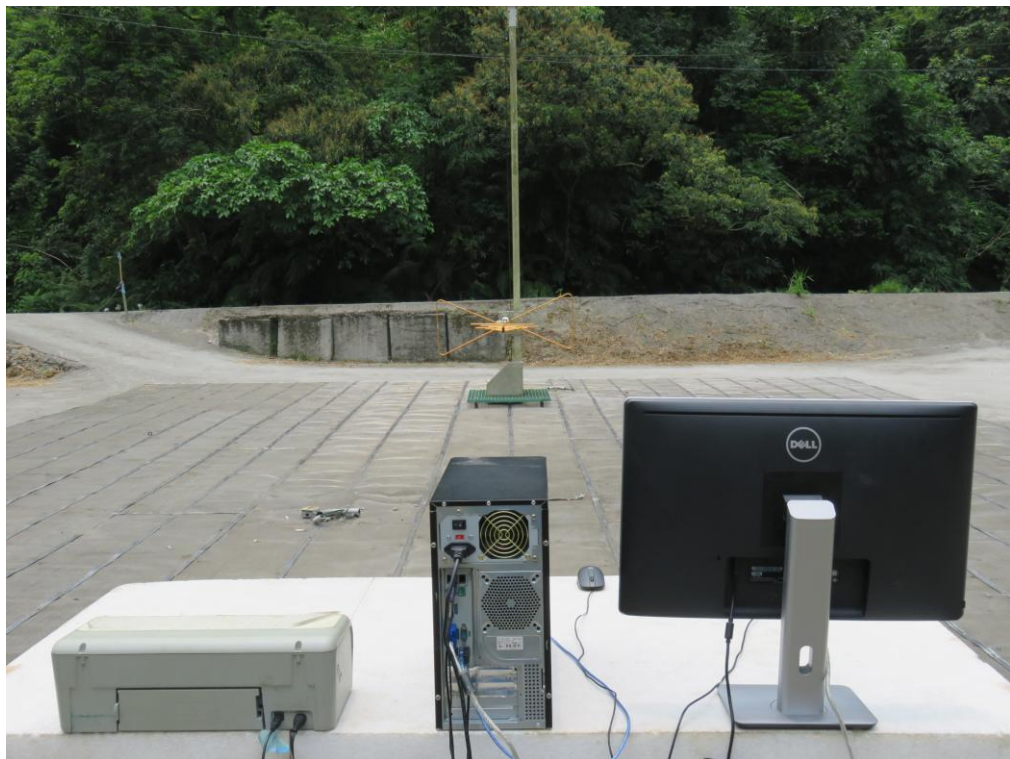



Photograph – Radiated Emission Test Setup-Above 1GHz





Photograph –ESD Test Setup



Photograph –RS Test Setup





Photograph –EFT Test Setup



Photograph –Surge & DIPS Test Setup

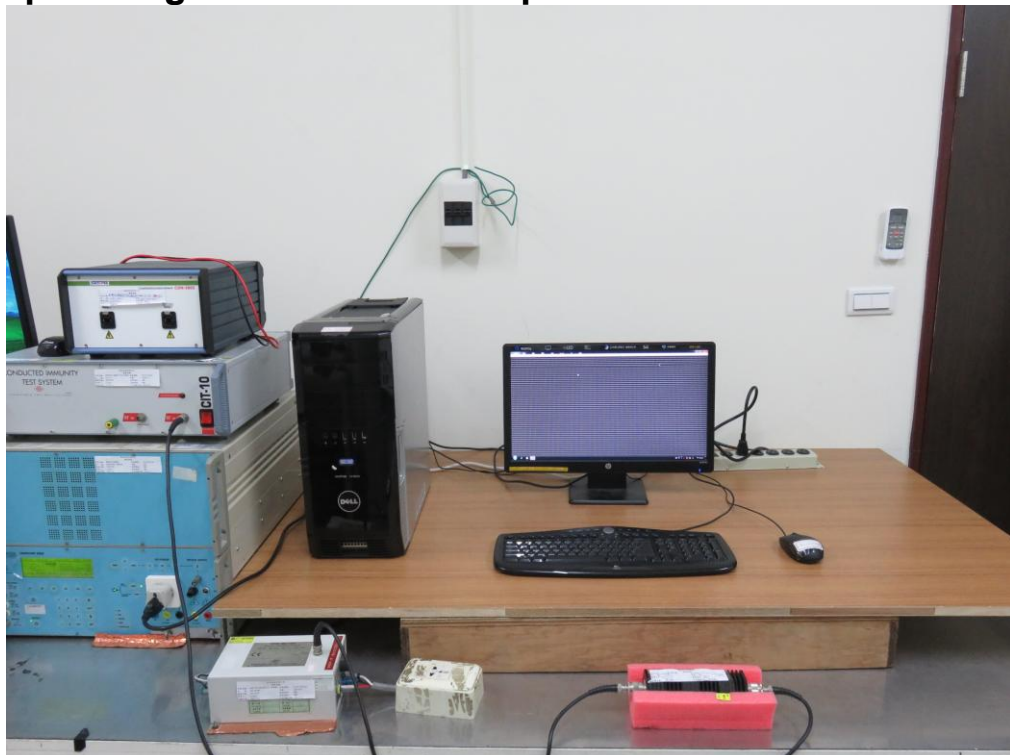



Photograph –CS Test Setup



Photograph –PFMF Test Setup





APPENDIX 2 TEST DATA

Test Data – Conducted Emission

Phase: L

Date: 2016-08-26

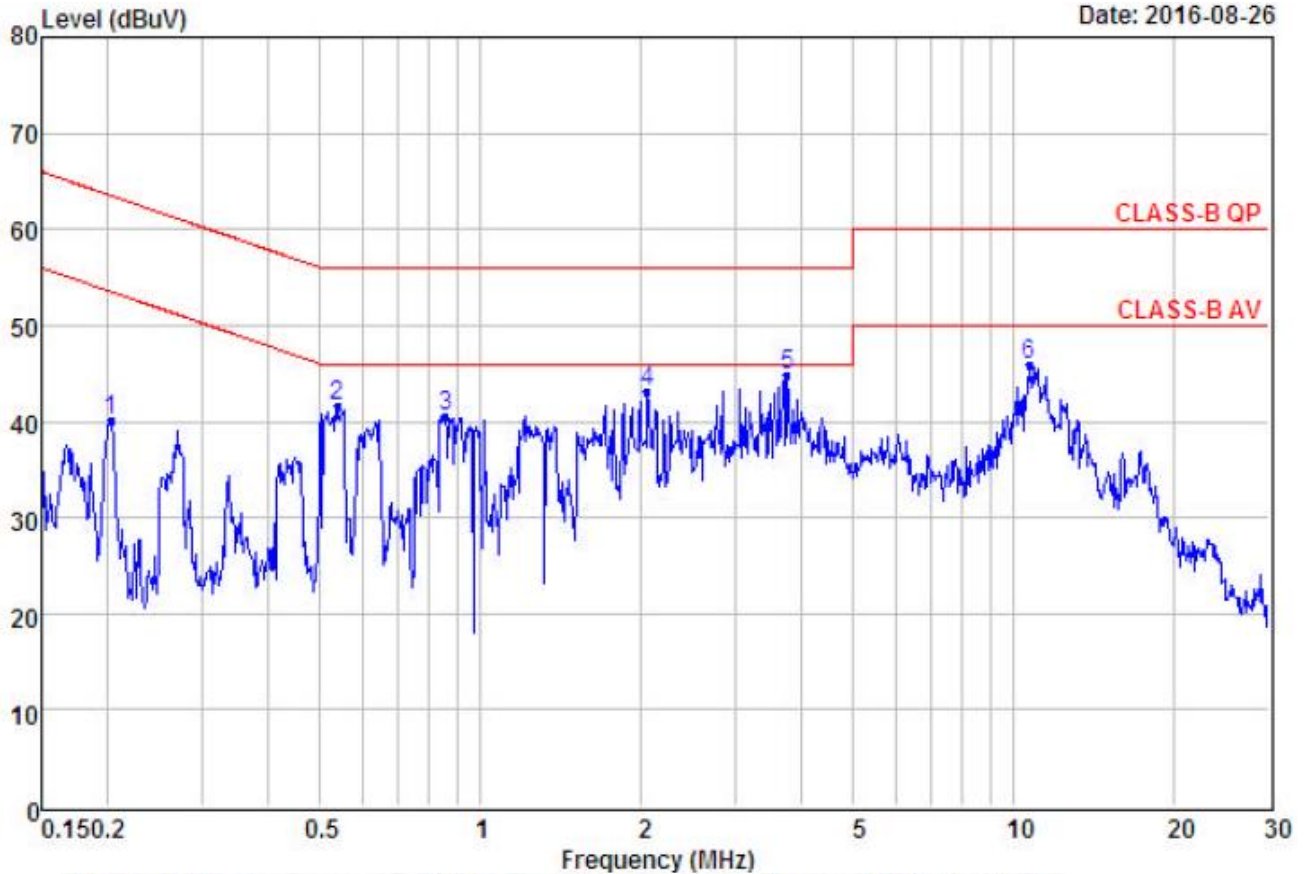

Remarks:

: Factor=Insertion loss+Cable loss

| | Freq | Read Level | Level | Factor | Over Limit | Limit Line | Remark |
|-----|-------|------------|-------|--------|------------|------------|--------|
| | MHz | dBuV | dBuV | dB | dB | dBuV | |
| 1 | 0.20 | 39.99 | 40.13 | 0.14 | -23.36 | 63.49 | Peak |
| 2 | 0.54 | 41.41 | 41.55 | 0.14 | -14.45 | 56.00 | Peak |
| 3 | 0.86 | 40.39 | 40.55 | 0.16 | -15.45 | 56.00 | Peak |
| 4 | 2.05 | 42.96 | 43.18 | 0.22 | -12.82 | 56.00 | Peak |
| 5 @ | 3.76 | 44.48 | 44.78 | 0.30 | -11.22 | 56.00 | Peak |
| 6 | 10.68 | 45.42 | 45.91 | 0.49 | -14.09 | 60.00 | Peak |



Phase: N

Date: 2016-08-26

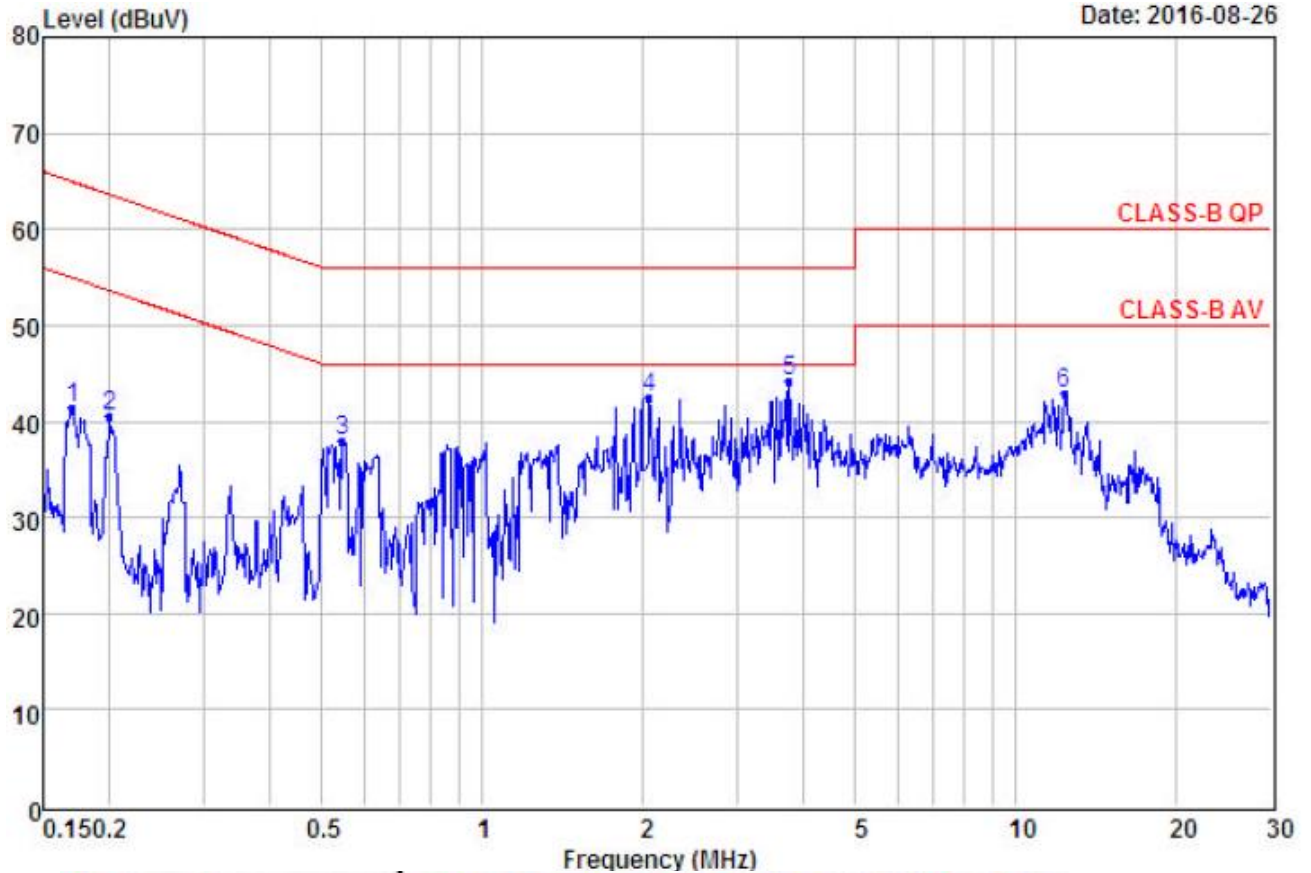

Remarks:

: Factor=Insertion loss+Cable loss

| | Read | Over | Limit | | | |
|------|-------|-------|--------|--------|-------|--------|
| Freq | Level | Level | Factor | Limit | Line | Remark |
| MHz | dBuV | dBuV | dB | dB | dBuV | |
| 1 | 41.29 | 41.38 | 0.09 | -23.56 | 64.94 | Peak |
| 2 | 40.41 | 40.52 | 0.11 | -23.10 | 63.62 | Peak |
| 3 | 37.76 | 37.93 | 0.17 | -18.07 | 56.00 | Peak |
| 4 | 42.25 | 42.43 | 0.18 | -13.57 | 56.00 | Peak |
| 5 @ | 43.82 | 44.08 | 0.26 | -11.92 | 56.00 | Peak |
| 6 | 42.45 | 42.93 | 0.48 | -17.07 | 60.00 | Peak |



Test Data – Radiated Emission-Below 1GHz

Polarization: Horizontal

Date: 2016-08-26

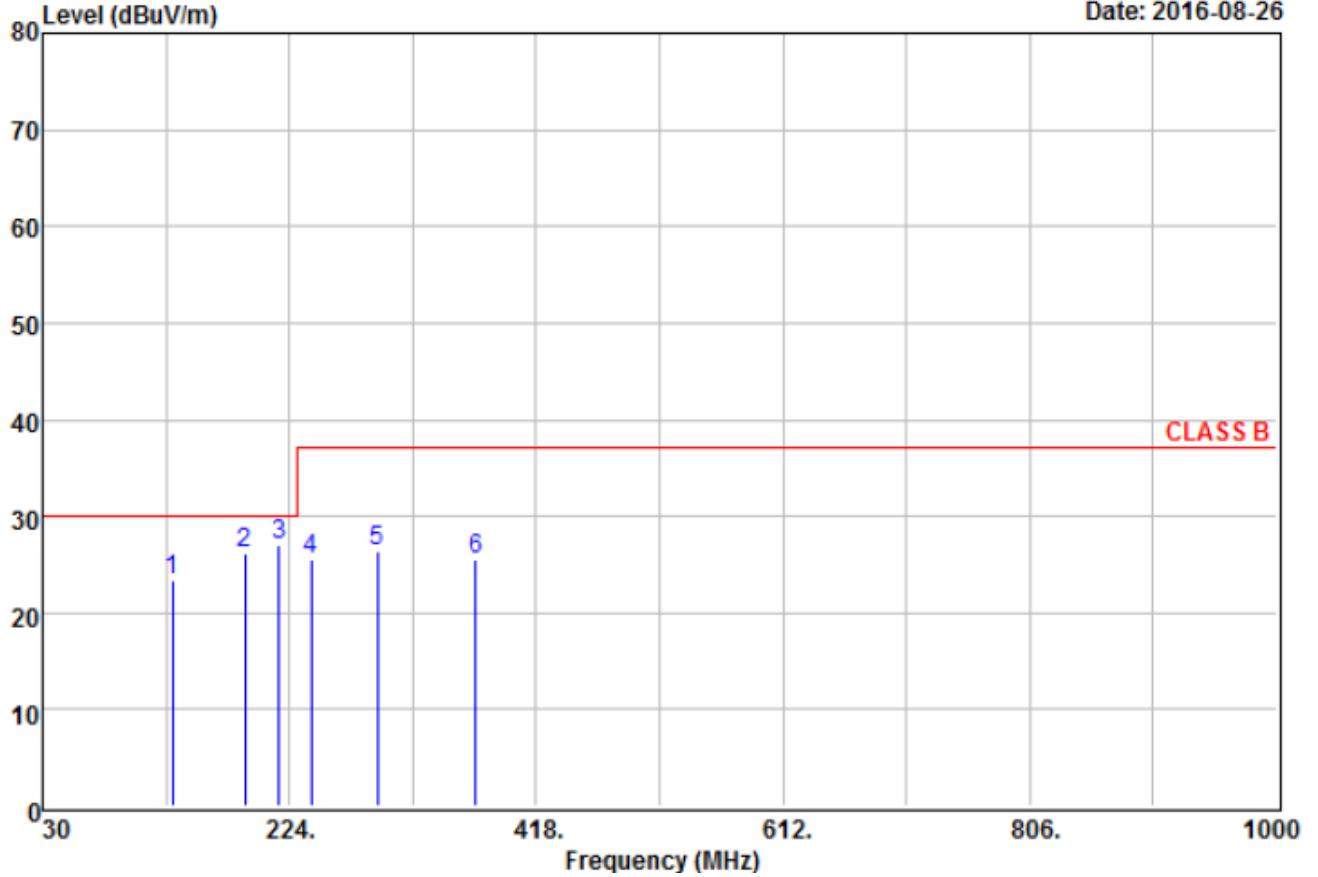

Remarks:
 : 1.Result=Read Value+Factor
 : 2.Factor=Antenna Factor+Cable loss-
 : Amplifier Factor

| | Freq | Read Level | Factor | Level | Limit Line | Over Limit | Remark |
|-----|--------|------------|--------|--------|------------|------------|--------|
| | MHz | dBuV | dB/m | dBuV/m | dBuV/m | dB | |
| 1 | 131.85 | 39.21 | -15.87 | 23.34 | 30.00 | -6.66 | QP |
| 2 | 189.08 | 45.79 | -19.61 | 26.18 | 30.00 | -3.82 | QP |
| 3 @ | 216.24 | 46.38 | -19.34 | 27.04 | 30.00 | -2.96 | QP |
| 4 | 241.46 | 42.27 | -16.64 | 25.63 | 37.00 | -11.37 | QP |
| 5 | 292.87 | 40.60 | -14.15 | 26.45 | 37.00 | -10.55 | QP |
| 6 | 370.47 | 38.06 | -12.47 | 25.59 | 37.00 | -11.41 | QP |



Polarization: Vertical

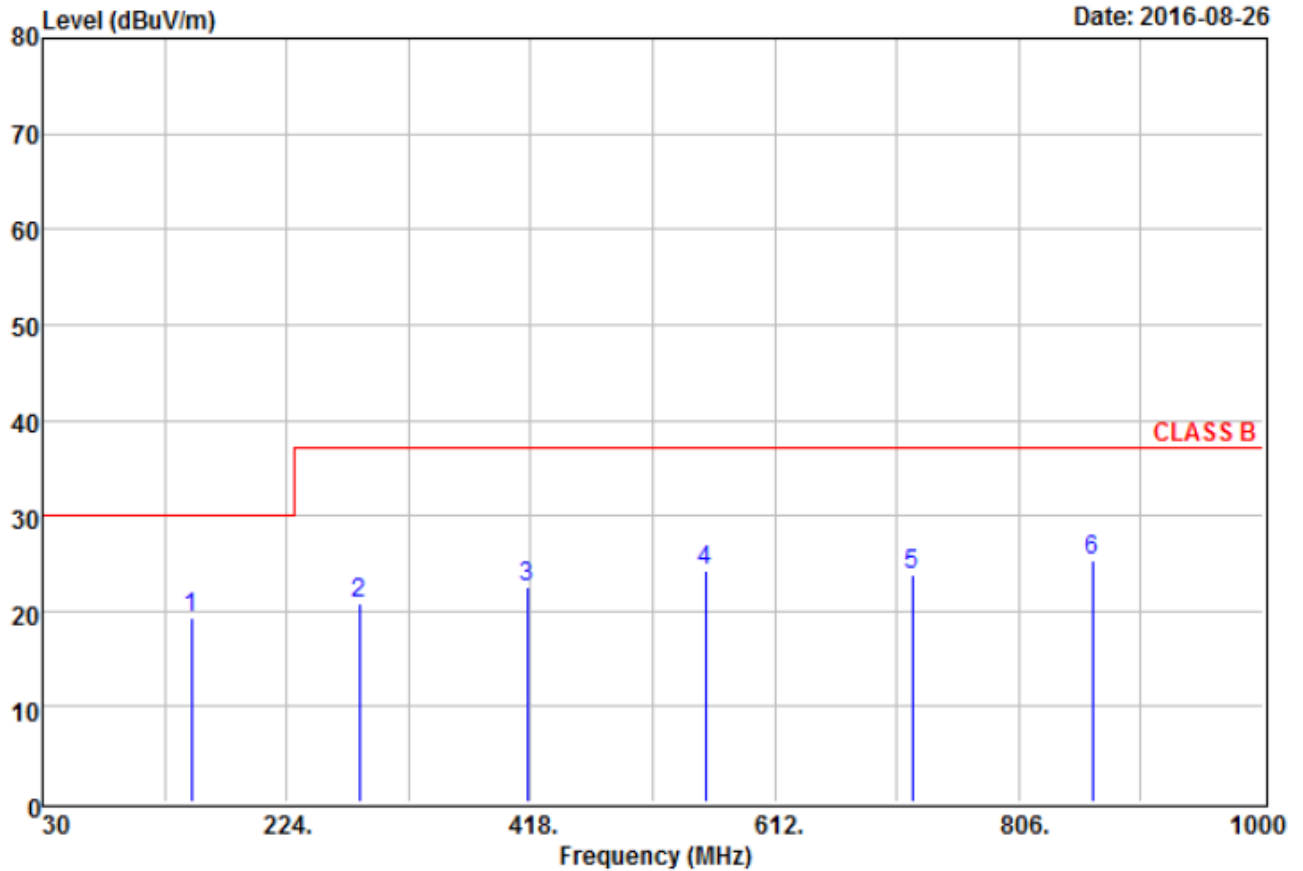

Remarks: : 1.Result=Read Value+Factor
: 2.Factor=Antenna Factor+Cable loss-
: Amplifier Factor

| | Freq | Read Level | Factor | Level | Limit Line | Over Limit | Remark |
|-----|--------|------------|--------|--------|------------|------------|--------|
| | MHz | dBuV | dB/m | dBuV/m | dBuV/m | dB | |
| 1 @ | 148.34 | 36.59 | -17.19 | 19.40 | 30.00 | -10.60 | QP |
| 2 | 282.20 | 35.32 | -14.46 | 20.86 | 37.00 | -16.14 | QP |
| 3 | 415.09 | 34.10 | -11.48 | 22.62 | 37.00 | -14.38 | QP |
| 4 | 556.71 | 33.99 | -9.86 | 24.13 | 37.00 | -12.87 | QP |
| 5 | 721.61 | 31.59 | -7.72 | 23.87 | 37.00 | -13.13 | QP |
| 6 | 864.20 | 30.68 | -5.46 | 25.22 | 37.00 | -11.78 | QP |



Polarization: Vertical

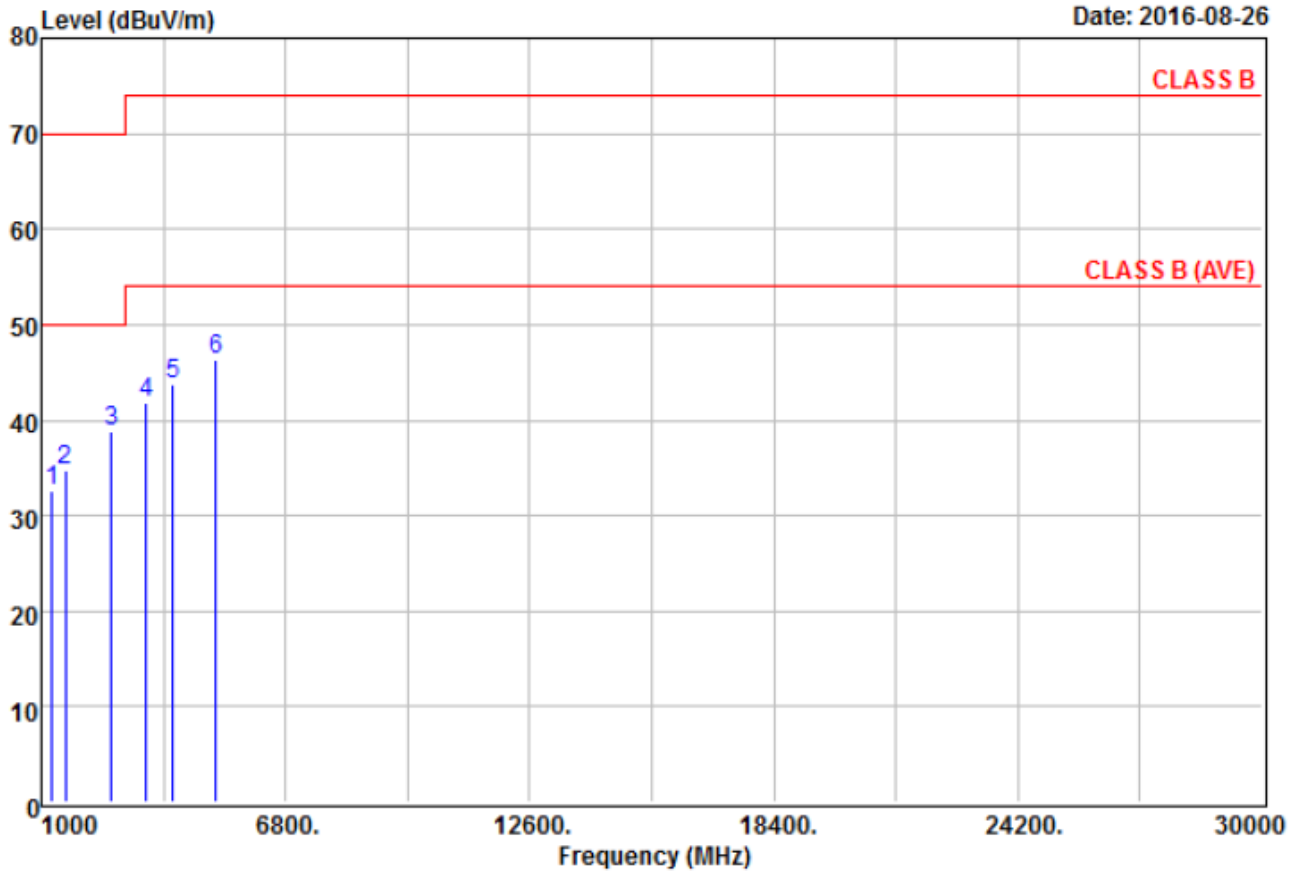

Remarks:
 : 1.Result=Read Value+Factor
 : 2.Factor=Antenna Factor+Cable loss-
 : Amplifier Factor

| | Freq | Read Level | Factor | Level | Limit Line | Over Limit | Remark |
|-----|---------|------------|--------|--------|------------|------------|--------|
| | MHz | dBuV | dB/m | dBuV/m | dBuV/m | dB | |
| 1 | 1251.00 | 52.06 | -19.47 | 32.59 | 70.00 | -37.41 | Peak |
| 2 | 1565.00 | 52.73 | -18.08 | 34.65 | 70.00 | -35.35 | Peak |
| 3 | 2659.00 | 52.00 | -13.28 | 38.72 | 70.00 | -31.28 | Peak |
| 4 | 3485.00 | 52.51 | -10.69 | 41.82 | 74.00 | -32.18 | Peak |
| 5 | 4136.00 | 51.91 | -8.23 | 43.68 | 74.00 | -30.32 | Peak |
| 6 @ | 5147.00 | 52.07 | -5.68 | 46.39 | 74.00 | -27.61 | Peak |



Harmonic

EMC PARTNER AG , Laufen

Date : 2016/8/26 下午 01:26 V4.18

File :

Operator

Unit

Serial Number

Remarks

Urms = 216.0V Freq = 59.981 Range: 5 A
Irms = 0.444A Ipk = 1.138A cf = 2.560
P = 75.47WS = 95.96VA pf = 0.786
THDi = 59.8 % THDu = 1.70 % Class A
Test completed, Result: PASSED

| Order | Freq. [Hz] | Iavg [A] | Irms [A] | Imax [A] | Limit | Status |
|-------|---------------|-------------|-------------|-------------|--------|--------|
| 1 | 60 | 0.3565 | 0.3561 | 0.3781 | | |
| 2 | 1200.0083 | 0.0085 | 0.0110 | 1.0800 | | |
| 3 | 1800.2395 | 0.2380 | 0.2496 | 2.3000 | | |
| 4 | 2400.0061 | 0.0061 | 0.0070 | 0.4300 | | |
| 5 | 3000.1036 | 0.1028 | 0.1065 | 1.1400 | | |
| 6 | 3600.0000 | 0.0027 | 0.0031 | 0.3000 | | |
| 7 | 4200.0457 | 0.0458 | 0.0479 | 0.7700 | | |
| 8 | 4800.0000 | 0.0024 | 0.0027 | 0.2300 | | |
| 9 | 5400.0191 | 0.0189 | 0.0198 | 0.4000 | | |
| 10 | 6000.0000 | 0.0012 | 0.0015 | 0.1840 | | |
| 11 | 6600.0188 | 0.0189 | 0.0195 | 0.3300 | | |
| 12 | 7200.0000 | 0.0009 | 0.0012 | 0.1533 | | |
| 13 | 7800.0044 | 0.0049 | 0.0064 | 0.2100 | | |
| 14 | 8400.0000 | 0.0009 | 0.0012 | 0.1314 | | |
| 15 | 9000.0085 | 0.0085 | 0.0092 | 0.1500 | | |
| 16 | 9600.0000 | 0.0006 | 0.0009 | 0.1150 | | |
| 17 | 1020 | 0.0000 | 0.0043 | 0.0046 | 0.1324 | |
| 18 | 1080 | 0.0000 | 0.0009 | 0.0009 | 0.1022 | |
| 19 | 1140 | 0.0054 | 0.0052 | 0.0061 | 0.1184 | |
| 20 | 1200 | 0.0000 | 0.0006 | 0.0009 | 0.0920 | |
| 21 | 1260 | 0.0003 | 0.0043 | 0.0049 | 0.1071 | |
| 22 | 1320 | 0.0000 | 0.0012 | 0.0015 | 0.0836 | |
| 23 | 1380 | 0.0000 | 0.0043 | 0.0046 | 0.0978 | |
| 24 | 1440 | 0.0000 | 0.0015 | 0.0015 | 0.0767 | |
| 25 | 1500 | 0.0000 | 0.0037 | 0.0049 | 0.0900 | |
| 26 | 1560 | 0.0000 | 0.0012 | 0.0015 | 0.0708 | |
| 27 | 1620 | 0.0000 | 0.0027 | 0.0046 | 0.0833 | |
| 28 | 1680 | 0.0000 | 0.0012 | 0.0015 | 0.0657 | |
| 29 | 1740 | 0.0000 | 0.0031 | 0.0043 | 0.0776 | |
| 30 | 1800 | 0.0000 | 0.0012 | 0.0015 | 0.0613 | |
| 31 | 1860 | 0.0000 | 0.0018 | 0.0027 | 0.0726 | |
| 32 | 1920 | 0.0000 | 0.0009 | 0.0009 | 0.0575 | |
| 33 | 1980 | 0.0000 | 0.0034 | 0.0043 | 0.0682 | |
| 34 | 2040 | 0.0000 | 0.0009 | 0.0012 | 0.0541 | |
| 35 | 2100 | 0.0000 | 0.0018 | 0.0024 | 0.0643 | |
| 36 | 2160 | 0.0000 | 0.0009 | 0.0009 | 0.0511 | |
| 37 | 2220 | 0.0000 | 0.0043 | 0.0046 | 0.0608 | |
| 38 | 2280 | 0.0000 | 0.0009 | 0.0009 | 0.0484 | |



| | | | | | |
|----|------|--------|--------|--------|--------|
| 39 | 2340 | 0.0000 | 0.0012 | 0.0015 | 0.0577 |
| 40 | 2400 | 0.0000 | 0.0009 | 0.0009 | 0.0460 |

Important:
- 100% of time voltage "out of Spec"

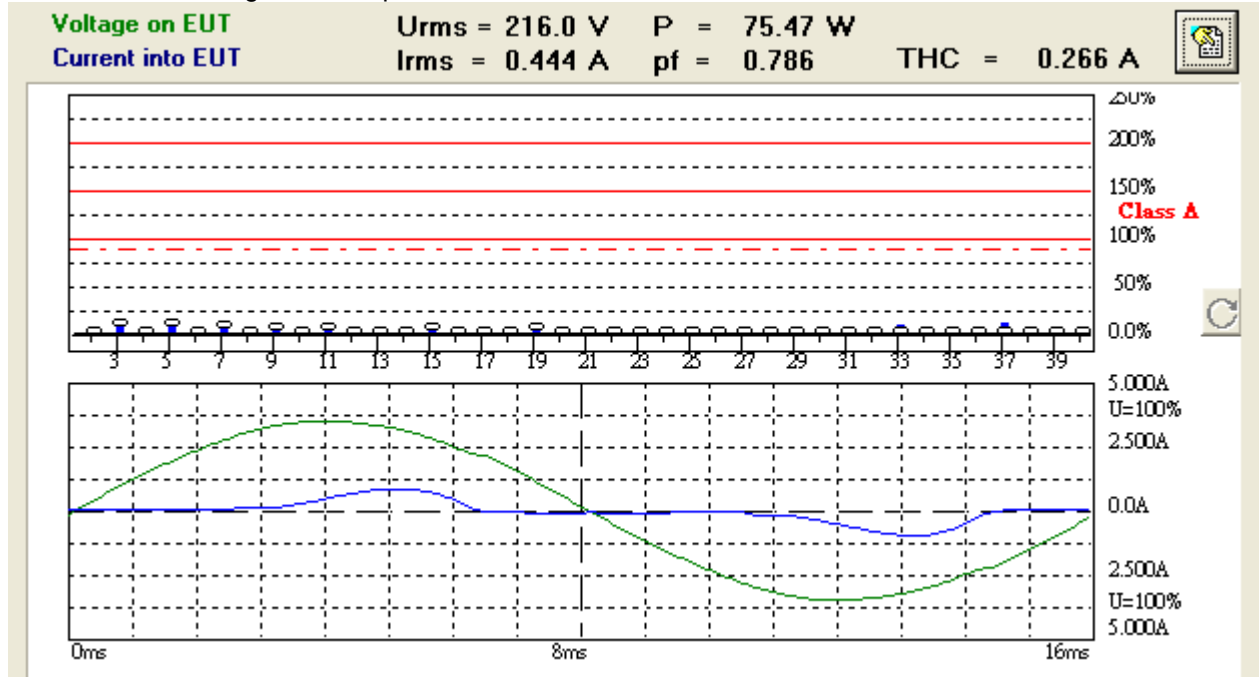



Flicker

EMC PARTNER AG , Laufen

Date : 2016/8/26 下午 02:27 V4.18

File :

Operator

Unit

Serial Number

Remarks

Urms = 217.5V Freq = 60.038 Range: 5 A
Irms = 0.430A Ipk = 1.079A cf = 2.511
P = 73.99WS = 93.48VA pf = 0.792

LIN (Line Impedance Network) : L: 0.24ohm +j0.15ohm N: 0.16ohm +j0.10ohm

Limits : Plt : 0.65 Pst : 1.00
dmax : 4.00 % dc : 3.00 %
dtLim: 3.00 % dt>Lim: 200ms

Test completed, Result: PASSED

dmax
[%]
1 0.000



PHOTOS OF EUT

