



EMC TEST REPORT

FOR

SATA Flash Drive

Model : SX240-297
Trade Name: Apacer

Issued to

Apacer Technology Inc.

1F., No.32, Zhongcheng Rd., Tucheng Dist., New Taipei City 236, Taiwan
(R.O.C)

Issued by

WH Technology Corp.

Xizhi Office and Lab	7F., No.262, Sec. 3, Datong Rd., Xizhi Dist., New Taipei City 221, Taiwan, (R.O.C.)
Tel.: +886-2-7729-7707 Fax: +886-2- 8648-1311	

Note: This test refers exclusively to the test presented test model and sample. This report shall not be reproduced except in full, without the written approval of WH Technology Corp. This document may be altered or revised by WH Technology Corp. Personnel only, and shall be noted in the revision section of the document.



TABLE OF CONTENTS

REVISION HISTORY ----- 4

1. GENERAL INFORMATION5

1.1 DESCRIPTION OF THE TESTED SAMPLES6

1.2 SUMMARY OF TEST RESULT7

1.3 TEST FACILITY8

1.4 TEST METHODOLOGY9

1.5 DESCRIPTION OF THE SUPPORT EQUIPMENTS.....11

1.6 FEATURES OF EUT:11

2. INSTRUMENT AND CALIBRATION.....12

2.1 MEASURING INSTRUMENT CALIBRATION 12

2.2 TEST AND MEASUREMENT EQUIPMENT12

2.3 TEST PERFORMED.....14

2.4 APPENDIX.....14

3. CONDUCTED EMISSION MEASUREMENT16

3.1 TEST SET-UP16

3.2 LIMIT.....16

3.3 TEST PROCEDURE.....16

3.4 TEST SPECIFICATION17

3.5 RESULT: PASSED17

3.6 TEST DATA:.....17

3.7 LIMIT OF CONDUCTED COMMON MODE DISTURBANCE AT TELECOMMUNICATION PORT.....18

3.8 RESULT OF CONDUCTED COMMON MODE DISTURBANCE AT TELECOMMUNICATION PORT.18

4. RADIATED EMISSION MEASUREMENT19

4.1 TEST SETUP19

4.2 LIMIT.....20

4.3 TEST PROCEDURE.....20

4.4 TEST SPECIFICATION20

4.5 RESULT: PASSED.....21

4.6 TEST DATA:.....21

5. POWER HARMONIC MEASUREMENT22

5.1 TEST SETUP22

5.2 LIMITS22

5.3 TEST PROCEDURE.....23

5.4 TEST SPECIFICATION23

5.5 RESULT: PASSED23

5.6 TEST DATA:.....23

6. VOLTAGE FLUCTUATIONS24

6.1 TEST SETUP24

6.2 LIMITS24

6.3 TEST PROCEDURE.....24

6.4 TEST SPECIFICATION24

6.5 RESULT: PASSED24

6.6 TEST DATA:.....24

7. PERFORMANCE CRITERIA25

8. ELECTROSTATIC DISCHARGE IMMUNITY TEST (ESD)26

8.1 TEST SETUP.....26

8.2 TEST SPECIFICATION26



8.3	TEST LEVEL.....	26
8.4	TEST PROCEDURE	26
8.5	TEST RESULT:.....	27
9.	RADIATED SUSCEPTIBILITY MEASUREMENT (RS).....	30
9.1	TEST SETUP	30
9.2	TEST SPECIFICATION	30
9.3	TEST LEVEL.....	30
9.4	TEST PROCEDURE.....	30
9.5	TEST RESULT:.....	31
10.	ELECTRICAL FAST TRANSIENT/BURST (EFT)	32
10.1	TEST SETUP	32
10.2	TEST SPECIFICATION	32
10.3	TEST PROCEDURE.....	32
10.4	TEST LEVEL.....	33
10.5	TEST RESULT.....	33
11.	SURGE.....	35
11.1	TEST SETUP	35
11.2	TEST SPECIFICATION	35
11.3	TEST LEVEL.....	35
11.4	TEST PROCEDURE.....	35
11.5	TEST RESULT	36
12.	IMMUNITY TEST TO CS CONDUCTED DISTURBANCE (CS)	37
12.1	TEST SETUP	37
12.2	TEST SPECIFICATION.....	37
12.3	TEST LEVEL.....	37
12.4	TEST PROCEDURE.....	38
12.5	TEST RESULT.....	38
13.	POWER FREQUENCY MAGNETIC FIELD (PFMF)	39
13.1	TEST SETUP	39
13.2	TEST SPECIFICATION.....	39
13.3	TEST LEVEL.....	39
13.4	TEST PROCEDURE.....	39
13.5	TEST RESULT.....	39
14.	VOLTAGE DIPS AND INTERRUPTION MEASUREMENT(DIPS).....	41
14.1	TEST SETUP	41
14.2	TEST SPECIFICATION	41
14.3	TEST LEVEL.....	41
14.4	TEST PROCEDURE.....	42
14.5	TEST RESULT.....	42
15.	MEASUREMENT UNCERTAINTY	43
APPENDIX 1		44
APPENDIX 2		50
PHOTS OF EUT		61



REVISION HISTORY

Rev.	Issue Date	Revisions	Effect Page	Revised By
00	Nov. 05, 2019	Initial Issue	ALL	Maggie



1. GENERAL INFORMATION

Applicant : Apacer Technology Inc.
Address : 1F., No.32, Zhongcheng Rd., Tucheng Dist., New Taipei City
236, Taiwan (R.O.C)
Manufacturer : Apacer Technology Inc.
Address : 1F., No.32, Zhongcheng Rd., Tucheng Dist., New Taipei City
236, Taiwan (R.O.C)
EUT : SATA Flash Drive
Model Name : SX240-297
Model Differences : N/A
Receipt Date : Oct. 23, 2019
Final Test Date : Nov. 05, 2019

Measurement procedure used:

EMI :

EN 55032 : 2015

EN 61000-3-2 : 2014

EN 61000-3-3 : 2013

CISPR 32 : 2015

EMS:

EN 55035 : 2017

IEC 61000-4-2 : 2008

IEC 61000-4-3 : 2006+A1:2007+A2:2010

IEC 61000-4-4 : 2012

IEC 61000-4-5 : 2014

IEC 61000-4-6 : 2013/COR1:2015

IEC 61000-4-8 : 2009

IEC 61000-4-11 : 2004

Deviation from Applicable Standard

The above equipment was tested by WH Technology Corp. for compliance with EMC requirements set forth in the EUROPEAN COUNCIL DIRECTIVE 2014/30/EU and the technical standards mentioned above. The results of testing in this report apply only to the product/system, which was tested. Other similar equipment will not necessarily produce the same results due to production tolerance.

This test report shall not be reproducing in part without written approval of WH Technology Corp.

Tested By:

Reviewed by:

Nov. 05, 2019

Date

Bing Chang/ Engineer

Nov. 05, 2019

Date

Bell Wei / Manager
TAF Accreditation Number: 2954



1.1 DESCRIPTION OF THE TESTED SAMPLES

EUT Name : SATA Flash Drive
Model Number : SX240-297
Receipt Date : 10/23/2019
EUT Power Rating : AC 220V/50Hz
 DC 12V
 DC 5V from PC
 DC 12V from Adaptor AC 230V/50Hz
EUT highest operating frequency : Above 108MHz
EUT Covered : N/A
I/O Port of EUT : N/A



1.2 SUMMARY OF TEST RESULT

Test Result measurement is not including uncertainty.

Emission				
Test Standard	Test Item	Limit	Test Result	Remark
EN 55032: 2015	Conducted emission	Class B	PASS	
	Conducted emission at telecommunication ports	Class B	N/A	NOTE (1)
	Radiated emission Below 1 GHz	Class B	PASS	
	Radiated emission Above 1 GHz	Class B	PASS	NOTE (2)
EN 61000-3-2: 2014	Harmonic current emissions	Class A	PASS	NOTE (3)
EN 61000-3-3: 2013	Voltage fluctuations	-----	PASS	

Immunity EN 55035:2017				
Test Standard	Test Item	Performance Criterion	Test Result	Remark
IEC 61000-4-2: 2008	Electrostatic discharge	B	Pass	
IEC 61000-4-3: 2006 +A1: 2007 +A2: 2010	Radiated Frequency electromagnetic field	A	Pass	
IEC 61000-4-4: 2012	Electrical fast transient/burst	B	Pass	
IEC 61000-4-5: 2014	Surge	B / C	Pass	NOTE (4)
IEC 61000-4-6: 2013/COR1: 2015	Conducted Disturbances induced by Radio-Frequency Fields	A	Pass	
IEC 61000-4-8: 2009	Power Frequency Magnetic Field	A	Pass	
IEC 61000-4-11: 2004	Voltage Dips and Interruption	B / C / C NOTE (5)	Pass	

NOTE:

- 1) "N/A" denotes test is not applicable in this Test Report.
- 2) If the EUT's highest operating frequency does not exceed 108 MHz, the test will not be performed.
- 3) if the EUT's category is Class D and power consumption is less than 75W, there is no limit applied.
- 4) Performance Criterion B for input a.c. and d.c. power ports.
Performance Criterion C for signal ports and telecommunication ports.
- 5) Voltage Dips: >95% - Performance Criterion B
Voltage Dips: 30% - Performance Criterion C
Voltage Interruption: >95% - Performance Criterion C



1.3 TEST FACILITY

The test facilities used to collect the test data in this report:

Conducted emission Test:

C01: 7F., No.262, Sec. 3, Datong Rd., Xizhi Dist., New Taipei City 221, Taiwan, (R.O.C.)

C02: No. 67-22, Baoxin St., Xizhi Dist., New Taipei City 221, Taiwan (R.O.C.)

Conducted emission at telecommunication ports Test:

C01: 7F., No.262, Sec. 3, Datong Rd., Xizhi Dist., New Taipei City 221, Taiwan, (R.O.C.)

C02: No. 67-22, Baoxin St., Xizhi Dist., New Taipei City 221, Taiwan (R.O.C.)

Radiated emission Test (Below 1 GHz):

OS01: No.120, Ln. 5, Hudong St., Xizhi Dist., New Taipei City 221, Taiwan (R.O.C.)

CB02: No. 67-22, Baoxin St., Xizhi Dist., New Taipei City 221, Taiwan (R.O.C.)

Radiated emission Test (Above 1 GHz):

OS01: No.120, Ln. 5, Hudong St., Xizhi Dist., New Taipei City 221, Taiwan (R.O.C.)

CB02: No. 67-22, Baoxin St., Xizhi Dist., New Taipei City 221, Taiwan (R.O.C.)

The immunity test:

No. 67-22, Baoxin St., Xizhi Dist., New Taipei City 221, Taiwan (R.O.C.)



1.4 TEST METHODOLOGY

EUT SYSTEM OPERATION

1. All peripherals connect EUT and power on.
2. An executive program, "Ping.exe" was executed to transmit and receive data to the remote workstation through LAN.
3. An executive program, "TFGEN.exe" was executed to transmit and receive data to the Sever through LAN. During the disturbances at telecommunication port test, the condition of LAN utilization in excess of 10%.



DESCRIPITON OF TEST MODES

To investigate the maximum EMI emission characteristics generates from EUT, the test system was pre-scanning tested base on the consideration of following EUT operation mode or test configuration mode which possible have effect on EMI emission level. Each of these EUT operation mode(s) or test configuration mode(s) mentioned above was evaluated respectively.

Pretest Test Mode	Description
Mode 1	All system

Conducted emission test	
Final Test Mode	Description
Mode 1	All system

Radiated emission test	
Final Test Mode	Description
Mode 1	All system

Harmonic current emissions & Voltage fluctuations	
Final Test Mode	Description
Mode 1	All system

Immunity tests	
Final Test Mode	Description
Mode 1	All system



1.5 DESCRIPTION OF THE SUPPORT EQUIPMENTS

Setup Diagram

See test photographs attached in APPENDIX 1 for the actual connections between EUT and support equipment.

Support Equipment

OUTSIDE SUPPORT EQUIPMENT							
No.	Equipment	Model	Serial No.	FCC ID/ BSMI ID	Trade name	Data Cable	Power Cord
1.	PC	D19M	CYY7Y A00 DC4	R33002	DELL	N/A	Unshielded 1.8m
2.	Monitor	UZ2315Hf	CN-0NJ1C5-7287 2-473-AF2SREV A02	R43002	DELL	Shielded 1.8m	Unshielded 1.8m
3.	Printer	D4360	N/A	R33001	HP	Shielded 1.8m / USB	Unshielded 1.8m
4	USB 3.0	32G	AUC350-32G-CGD	D33A23	ADATA	Shielded 1m / USB	N/A
5	Mouse	MS116p	CN-04DWDN-7382 6-5CM-0120	R41108	DELL	Shielded 1.8m / USB	N/A
6	Keyboard	KB216p	CN-005TW2-71581- 5AF-01I3-A01	D41108	DELL	Shielded 1.8m / USB	N/A

Note:

- (1) The support equipment was authorized by Declaration of conformity (DOC).
- (2) All the above equipment/cable were placed in worse case position to maximize emission signals during emission test.
- (3) Grounding was established in accordance with the manufacturer's requirement and conditions for the intended use.

1.6 FEATURES OF EUT:

Please refer to user manual or product specification.



2. INSTRUMENT AND CALIBRATION

2.1 MEASURING INSTRUMENT CALIBRATION

The measuring equipment utilized to perform the tests documented in the report has been calibrated once a year or in accordance with the manufacturer's recommendations, and is traceable to recognized national standards.

2.2 TEST AND MEASUREMENT EQUIPMENT

The following list contains measurement equipment used for testing. The equipment conforms to the requirement of CISPR 16-1, ANSI C63.2 and. Other required standards. Calibration of all test and measurement, including any accessories that may effect such calibration, is checked frequently to ensure the accuracy. Adjustments are made and correction factors are applied in accordance with the instructions contained in the respective.

TABLELIST OF TEST AND MEASUREMENT EQUIPMENT

Conducted emission				
Instrument	Manufacturer	Model No.	Serial No.	Cali Due Date
EMI Test Receiver	R&S	ESHS10	830223/008	2020/06/09
Spectrum Analyzer	R&S	FSP3	833387/010	2019/12/05
Two-Line V-Network	Rolf Heine Hochfrequenz technik	NNB-2/16z	98062	2020/08/04
ISN	Schwarzbeck	8-Wire ISN CAT5	CAT5-8158-0094	2020/10/17
Test Cable	N/A	N/A	EMI-3	2020/10/10
Measurement Software	AUDIX	e3	V6.101222a	N/A
Radiated emission Below 1GHz				
Instrument	Manufacturer	Model No.	Serial No.	Cali Due Date
Bilog antenna	ETC	MCTD2786B	BLB16M04004/J B-5-004	2020/06/29
LOOP Antenna	EMCO	6507	146361	2019/12/13
Pre-amplifier	EMCI	EMC9135	980334	2020/06/10
Cable	EMCI	N male on end of both sides (EMI4)	30m	2019/12/06
Receiver	R&S	ESVS30	826006/002	2019/12/06
Spectrum Analyzer	R&S	FSP7	830180/006	2020/04/16
Measurement Software	AUDIX	e3	V6.101222a	N/A
Radiated emission Above 1GHz				
Instrument	Manufacturer	Model No.	Serial No.	Cali Due Date



Horn antenna	ETC	MCTD 1209	DRH15N02009	2019/12/13
Pre-amplifier	EMCI	EMC051845	980108	2019/12/06
RF CABLE	SUCOFLEX	104PEA	27348/4PEA	2020/06/10
RF CABLE	HARBOUR INDUSTRIES	LL142MI(7M)	N/A	2020/08/09
Spectrum Analyzer	ADVANTEST	R3182	150900201	2020/01/17
Measurement Software	AUDIX	e3	V6.101222a	N/A

Harmonic/Flicker				
Instrument	Manufacturer	Model No.	Serial No.	Cali Due Date
Power & Harmonics Analyzer	R&S	ESHS10	830223/008	2020/06/09
Measurement Software	EMC Partner	Harcs	V4.22	N/A
Immunity				
Instrument	Manufacturer	Model No.	Serial No.	Cali Due Date
ESD Simulator	Noiseken	ESS-2002	ESS0767151	2019/11/28
SIGNAL GENERATOR	Agilent	N5182A	MY50144390	2019/12/10
Log Periodic Antenna	SCHWARZBECK	STLP 9129	9129 101	N/A
Electric Field Probe	PMM	EP 601	611WX70786	2020/07/01
Power Meter	Agilent	E4419B	MY41291664	2019/12/06
Power Sensor	Agilent	8481D	MY41091347	2019/12/06
Power Sensor	Agilent	E9301	US39211864	2019/12/06
Amplifier	TESEQ	CBA 1G-300B	W2408-1218	N/A
Amplifier	MILMEGA	AS0860B-50-50	1085442	N/A
Measurement Software	AR	emcware	V3.6.0	N/A
EMC Immunity Test System	EMC PARTNER	TRANSIENT 2000IN6	456	2020/01/15
Capacitive Clamp	EMC PARTNER	CN-EFT1000	268	2020/01/15
Telccom Surge Module	SKYLARKSH	NSG 3060	0506C1817	2020/07/04
COUPLING/DECOUPLING NETWORK	SKYLARKSH	CDN-5802	05LN8A14001	2020/10/17
Conducted Immunity Test System	FRANKONIA	CIT-10-75-MIL	18901628-0101	2020/01/15
CDN	FRANKONIA	CDN M2+M3	A3011021	2020/02/12



CDN	FRANKONIA	CDN RJ45	A3023011	2020/06/13
EM clamp	FCC	F-203I-23MM	520	2020/01/17
Measurement Software	Frankonia	CD-LAB C5.315	V1435V2372015	N/A
Magnetic Field Immunity Loop	EMC PARTNER	MF-1000-1-69	169	2020/03/28
EMF Tester	TES	1390	110305943	2020/04/18

Remark: "N/A" denotes No Model Name, No Serial No. or No Calibration specified.

2.3 TEST PERFORMED

Conducted emissions were investigated over the frequency range from 0.15 MHz to 30 MHz using a receiver which resolution bandwidth is set at 9 kHz.

Radiated emissions were investigated over the frequency range from 30 MHz to 1000 MHz using a receiver which resolution bandwidth is set at 120 kHz. Radiated measurement was performed at distance that from an antenna to EUT is 10 meters.

2.4 APPENDIX

Appendix A: Measurement Procedure for Main Power Port Conducted Emissions

The measurements are performed in a WH lab test room; The EUT was placed on non-conductive 1.0m x 1.5m table, which is 0.8 meters above an earth-grounded.

Power to the EUT was provided through the LISN which has the Impedance (50 ohm/50 uH) vs. Frequency Characteristic in accordance with the standard. Powers to the LISNs were filtered to eliminate ambient signal interference and these filters were bonded to the ground plane. Peripheral equipment required to provide a functional system (support equipment) for EUT testing was powered from the second LISN through a ganged, metal power outlet box which is bonded to the ground plane at the LISN.

If the EUT is supplied with a flexible power cord, the power cord length in excess of the distance separating the EUT from the LISN shall be folded back and forth at the center of the lead so as to form a bundle not exceeding 40cm in length. If the EUT is provided with a permanently coiled power cord, bundling of the cord is not required. If the EUT is supplied without a power cord, the EUT shall be connected to the LISN by a power cord of the type specified by the manufacturer which shall not be longer than 1 meter. The excess power cord shall be bundled as described above. If a non-flexible power cord is provided with the EUT, it shall be cut to the length necessary to attach the EUT to the LISN and shall not be bundled.

The interconnecting cables were arranged and moved to get the maximum measurement. Both the line of power cord, hot and neutral, was measured.

The highest emissions were analyzed in details by operating the spectrum analyzer in fixed tuned mode to determine the nature of the emissions and to provide information which could be useful in reducing their amplitude.



Appendix B: Test Procedure for Radiated Emissions

Preliminary Measurements in 743 Semi Anechoic Chamber

The radiated emissions are initially measured in the anechoic chamber at a measurement distance of 3 meters. Desktop EUT are placed on a wooden stand 0.8 meter in height. The measurement antenna is 3 meters from the EUT. The test setup in anechoic chamber is the same as open site. The turntable rotated 360°C. The antenna height is 1m. The primary objective of the radiated measurements in the anechoic chamber is to identify the frequency spectrum in the absence of the electromagnetic environment existing on the open test site. The frequencies can then be pre-selected on the open test site to obtain the corresponding amplitude. The initial scan is made with the spectrum analyzer in automatic sweep mode. The spectrum peaks are then measured manually to determine the exact frequencies.

Measurements on the Open Site or 1166 Semi Anechoic Chamber

The radiated emissions test will then be repeated on the open site or chamber to measure the amplitudes accurately and without the multiple reflections existing in the shielded room. The EUT and support equipments are set up on the turntable. Desktop EUT are set up on a wooden stand 0.8 meter above the ground.

For the initial measurements, the receiving antenna is varied from 1-4-meter height and is changed in the vertical plane from vertical to horizontal polarization at each frequency. Both reading is recorded with the quasi-peak detector with 120 kHz bandwidth. For frequency between 30 MHz and 1000 MHz, the reading is recorded with peak detector or quasi-peak detector.

At the highest amplitudes observed, the EUT is rotated in the horizontal plane while changing the antenna polarization in the vertical plane to maximize the reading. The interconnecting cables were arranged and moved to get the maximum measurement. Once the maximum reading is obtained, the antenna elevation and polarization will be varied between specified limits to maximize the readings.



3. CONDUCTED EMISSION MEASUREMENT

3.1 TEST SET-UP

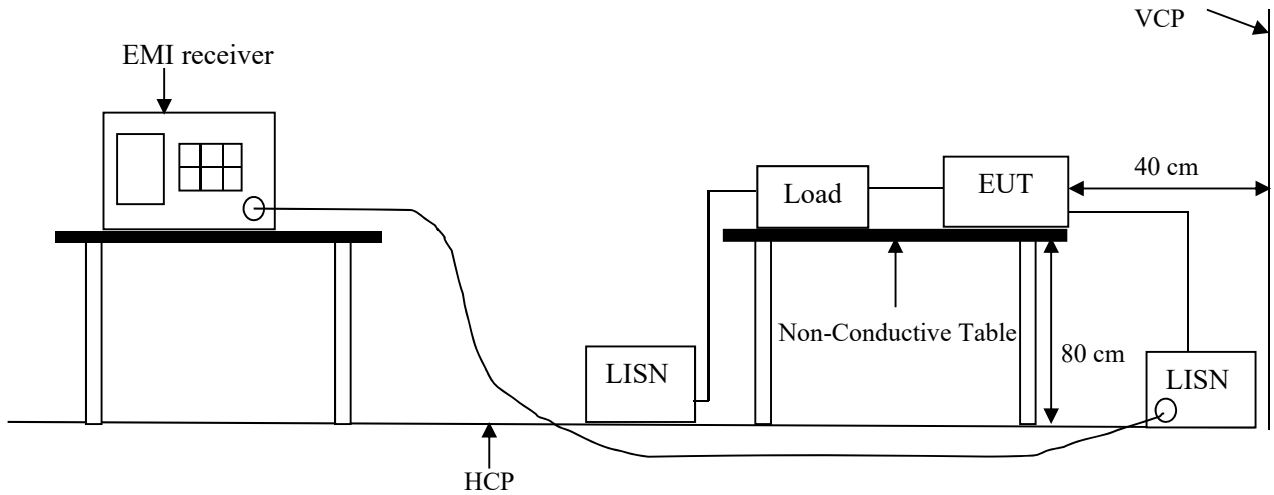

3.2 LIMIT

Frequency range (MHz)	CLASS A		CLASS B	
	QP (dBμV)	Average (dBμV)	QP (dBμV)	Average (dBμV)
0.15 – 0.5	79	66	66 - 56	56 - 46
0.5 – 5.0	73	60	56	46
5.0 – 30	73	60	60	50

NOTE:

- 1) In the above table, the tighter limit applies at the band edges.
- 2) The test result calculated as following:
 Level Value = Reading Level + Factor
 Factor = Insertion Loss + Cable Loss + Attenuator Factor (if use)
 Over Limit Value = Level Value – Limit Value

3.3 TEST PROCEDURE

Please refer to

Appendix A: Measurement Procedure for Main Power Port Conducted Emissions

Note:

1. Reading in which marked as Peak, QP or AVG means measurements by using are Quasi-Peak or Average Mode with Detector BW=9 kHz (6 dB Bandwidth).
2. All readings are Peak Mode value unless otherwise stated QP or AVG in column of Note. If the Peak or QP Mode Measured value compliance with the QP



Limits and lower than AVG Limits, the EUT shall be deemed to meet both QP & AVG Limits and then only Peak or QP Mode was measured, but AVG Mode didn't perform.

3.4 TEST SPECIFICATION

According to EN 55032 Class B

(Please refer to Page 5 for dated references which are related to the standard as mentioned above)

3.5 RESULT: PASSED

Model Name	SX240-297
Test Voltage	DC 5V
Temperature:	26 °C
Humidity:	54 % RH

3.6 TEST DATA:

Please refer to APPENDIX 2



3.7 LIMIT OF CONDUCTED COMMON MODE DISTURBANCE AT TELECOMMUNICATION PORT

TEST STANDARD: EN 55032

Frequency Range	Class A (dBµV)		Class B (dBµV)	
	Quasi Peak	Average	Quasi Peak	Average
0.15 – 0.5 MHz	97 – 87	84 – 74	84 – 74	74 – 64
0.5 – 30 MHz	87	74	74	64

NOTE:

- 1) The limits decrease linearly with the logarithm of the frequency in the range 0.15 MHz to 0.5MHz.
- 2) The test result calculated as following:
Level Value = Reading Level + Factor
Factor = Insertion Loss + Cable Loss + Attenuator Factor (if use)
Over Limit Value = Level Value – Limit Value

3.8 RESULT OF CONDUCTED COMMON MODE DISTURBANCE AT TELECOMMUNICATION PORT

TEST RESULT: **PASSED**, please refer to APPENDIX 2.

Note:

1. Reading in which marked as Peak, QP or AVG means measurements by using are Quasi-Peak or Average Mode with Detector BW=9 kHz (6 dB Bandwidth).
2. All readings are Peak Mode value unless otherwise stated QP or AVG in column of Note. If the Peak or QP Mode Measured value compliance with the QP Limits and lower than AVG Limits, the EUT shall be deemed to meet both QP & AVG Limits and then only Peak or QP Mode was measured, but AVG Mode didn't perform.



4. RADIATED EMISSION MEASUREMENT

4.1 TEST SETUP

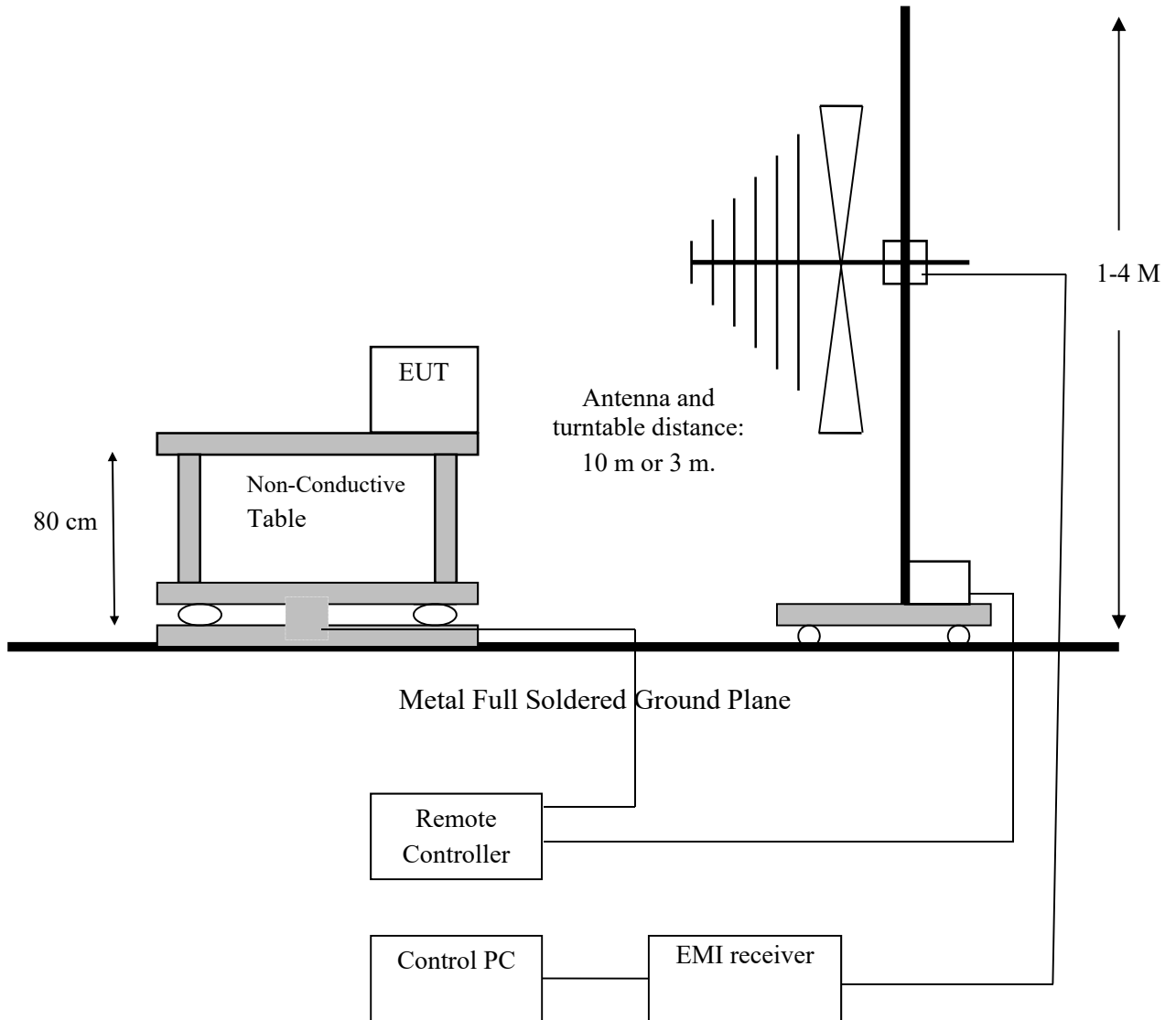



4.2 LIMIT

Frequency MHz	Class A		Class B	
	Quasi-peak at 3m (dB μ V/m)	Quasi-peak at 10m (dB μ V/m)	Quasi-peak at 3m (dB μ V/m)	Quasi-peak at 10m (dB μ V/m)
30 ~ 230	50	40	40	30
230 ~ 1000	57	47	47	37

Frequency range (GHz)	Class A (at 3m)		Class B (at 3m)	
	Average (dB μ V/m)	Peak (dB μ V/m)	Average (dB μ V/m)	Peak (dB μ V/m)
1 ~ 3	56	76	50	70
3 ~ 6	60	80	54	74

NOTE:

- 1) In the above table, the tighter limit applies at the band edges.
- 2) The test result calculated as following:
Level Value = Reading Level + Factor
Factor = Antenna Factor + Cable Loss – Amplifier Gain (if use)
Over Limit Value = Level Value – Limit Value

4.3 TEST PROCEDURE

Please refer to
Appendix B: Test Procedure for Radiated Emissions

Note:

(Below 1 GHz)

1. Reading in which marked as QP or Peak means measurements by using are Quasi-Peak Mode with Detector BW=120 kHz.
2. All readings are Peak unless otherwise stated QP in column of Note. Peak denotes that the Peak reading compliance with the QP Limits and then QP Mode measurement didn't perform.

(Above 1 GHz)

1. Reading in which marked as Peak means measurements by using are Peak Mode with instrument setting in RBW=1 MHz, VBW= 1MHz.
Reading in which marked as AV means measurements by using are Average Mode with instruments setting in RBW=1 MHz, VBW= 10Hz.
2. All readings are Peak Mode value unless otherwise stated AVG in column of Note. If the Peak be deemed to meet both Peak & AVG Limits and then only Peak Mode was measured, but AVG Mode didn't perform.

4.4 TEST SPECIFICATION

According to EN 55032 Class B



(Please refer to Page 5 for dated references which are related to the standard as mentioned above)

4.5 RESULT: PASSED

Model Name	SX240-297
Test Voltage	DC 5V
Temperature:	24 °C
Humidity:	70 % RH

4.6 TEST DATA:

Please refer to APPENDIX 2



5. POWER HARMONIC MEASUREMENT

5.1 TEST SETUP

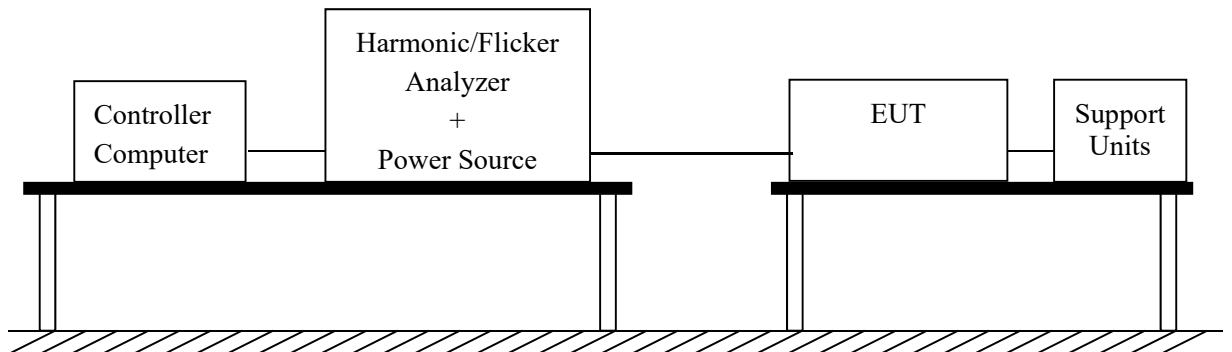

5.2 LIMITS

Limits for Class A equipment		Limits for Class D equipment		
Harmonic Order n	Maximum Permissible Harmonic Current A	Harmonic Order n	Maximum Permissible Harmonic Current mA/W	
Odd Harmonic		Odd Harmonic only		
3	2.30	3	2.30	3.4
5	1.14	5	1.14	1.9
7	0.77	7	0.77	1.0
9	0.40	9	0.40	0.5
11	0.33	11	0.33	0.35
13	0.21	13	0.21	0.30
15 ≤ n ≤ 39	0.15 x 15/n	15 ≤ n ≤ 39	0.15 x 15/n	3.85/n
Even Harmonic				
2	1.08			
4	0.43			
6	0.30			
8 ≤ n ≤ 40	0.23 x 8/n			

Note:

1. Class A and Class D are classified according to item section 5 of EN 61000-3-2:2014.
2. According to section 7 of EN 61000-3-2:2014, the above limits for all equipment except for lighting equipment are for all applications having an active input power > 75 W and no limits apply for equipment with an active input power up to and including 75W.



5.3 TEST PROCEDURE

The EUT was operated to produce the maximum harmonic components under normal operating conditions.

The correspondent test program of test instrument to measure the current harmonics emanated from EUT is chosen. The measure time shall be not less than the time necessary for the EUT to be exercised.

5.4 TEST SPECIFICATION

According to EN 61000-3-2

(Please refer to Page 5 for dated references which are related to the standard as mentioned above)

5.5 RESULT: PASSED

Model Name	SX240-297
Test Voltage	DC 5V
Temperature:	25°C
Humidity:	49 % RH

5.6 TEST DATA:

Please refer to APPENDIX 2



6. VOLTAGE FLUCTUATIONS

6.1 TEST SETUP

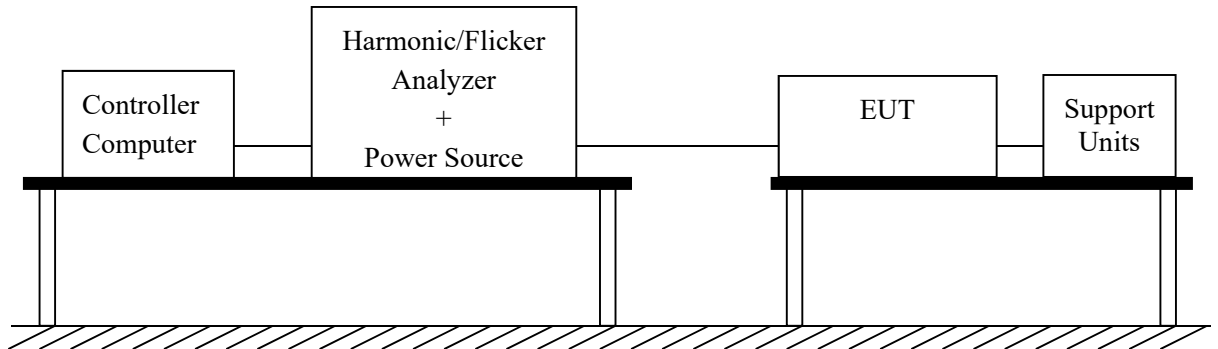

6.2 LIMITS

TEST ITEM	Limits	Descriptions
P_{st}	$\leq 1.0, T_p = 10 \text{ min.}$	Short Term Flicker Indicator
P_{lt}	$\leq 0.65, T_p = 2 \text{ hr.}$	Long Term Flicker Indicator
dc	$\leq 3.3\%$	Relative Steady-State V-Chang
d_{max}	$\leq 4\%$	Maximum Relative V-change
$d_{(t)}$	$\leq 3.3\% \text{ for } > 500\text{ms}$	Relative V-change characteristic

6.3 TEST PROCEDURE

Tests was performed according to the Test Conditions/Assessment of Voltage Fluctuations specified in EN 61000-3-3/IEC 61000-3-3 depend on which standard adopted for compliance measurement.

All types of harmonic current and/or voltage fluctuation in this report are assessed by direct measurement using flicker-meter.

6.4 TEST SPECIFICATION

According to EN 61000-3-3

(Please refers to Page 5 for dated references which are related to the standard as mentioned above)

6.5 RESULT: PASSED

Model Name	SX240-297
Test Voltage	DC 5V
Temperature:	25 °C
Humidity:	49 % RH

6.6 TEST DATA:

Please refer to APPENDIX 2



7. PERFORMANCE CRITERIA

- A. The apparatus shall continue to operate as intended during and after the test. No degradation of performance or loss of function is allowed below a performance level specified by the manufacturer, when the apparatus is used as intended.
- B. The apparatus shall continue to operate as intended after the test. No degradation of performance or loss of function is allowed below a performance level specified by the manufacturer, when the apparatus is used as intended. The performance level may be replaced by a permissible loss of performance. During the test, degradation of performance is however allowed.
- C. Temporary loss of function is allowed, provided the function is self-recoverable or can be restored by the operation of the controls.



8. ELECTROSTATIC DISCHARGE IMMUNITY TEST (ESD)

8.1 TEST SETUP

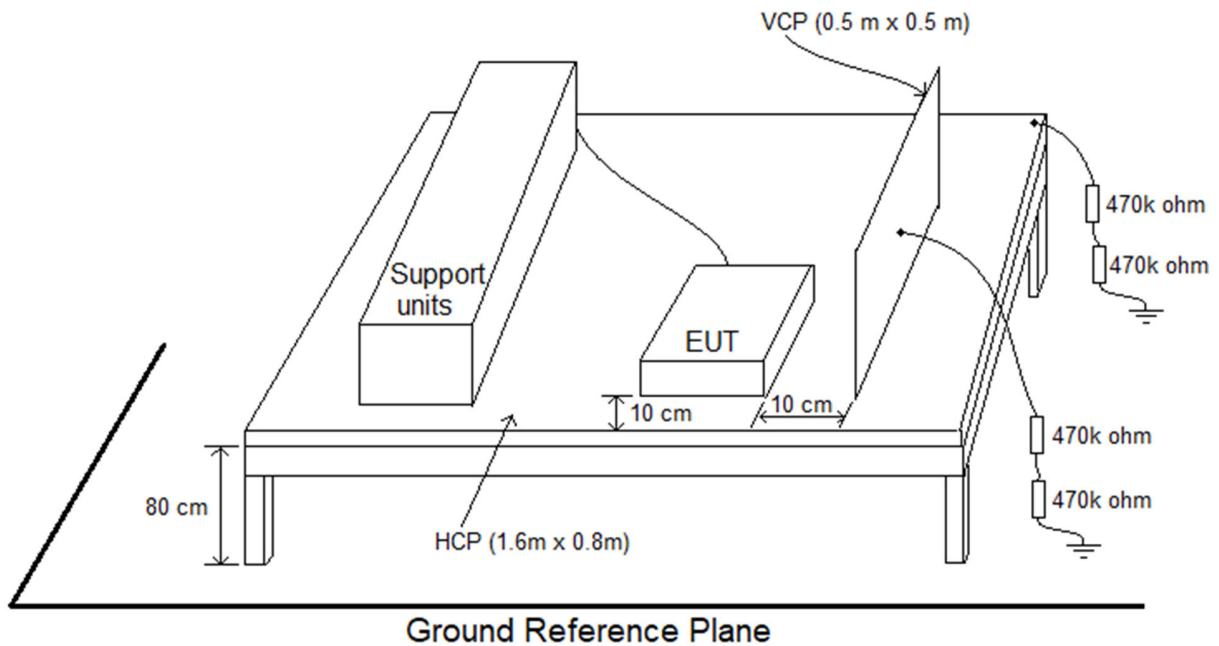

8.2 TEST SPECIFICATION

According to IEC 61000-4-2

(Please refer to Page 5 for dated references which are related to the standard as mentioned above)

8.3 TEST LEVEL

Item	Test Specification	Unit	Performance Criteria
Air Discharge	±2, 4, 8 (Direct)	kV (Charge Voltage)	B
Contact Discharge	±2,4 (Direct/Indirect)		
Discharge Period	1 (minimum)	sec	

Number of tests: 10 Discharges / Test point / Polarity / Level

8.4 TEST PROCEDURE

When the measurement was taken, The ESD discharger was performed in single discharge. For the single discharge time between successive single discharges will keep on one second. It was at least ten single discharges with positive and negative at the same selected pointed. The selected pointed, which was performed with electrostatic discharge, was marked on the red label on the EUT Indirect applicant of discharge to the EUT



Vertical Coupling Plane (VCP)

The coupling plane, of dimensions 0.5 m x 0.5 m, is placed parallel to, and positioned at a distance 0.1 m from, the EUT, with the discharge electrode touching the coupling plane.

The four faces of the EUT will be performed with electrostatic discharge. It was at least ten singles discharges with positive and negative at the same selected point.

Horizontal Coupling Plane (HCP)

The coupling plane is placed under the EUT. The generator shall be positioned vertically at a distance of 0.1m from the EUT, with the discharge electrode touching the coupling.

The four faces of the EUT will be performed with electrostatic discharge. It was at least ten single discharges with positive and negative at the same selected pointed.

8.5 TEST RESULT:

Model Name	SX240-297
Test Voltage	DC 5V
Temperature:	25 °C
Humidity:	49 % RH
Pressure	1002.2 hPa

Voltage	Contact Discharge				Air Discharge					
	2KV		4KV		2KV		4KV		8KV	
Polarity	+	-	+	-	+	-	+	-	+	-
Case	A	A	A	A	A	A	A	A	A	A
HCP	A	A	A	A	A	A	A	A	A	A
VCP	A	A	A	A	A	A	A	A	A	A

Note:

- 1) "--": denotes test is not applicable.
- 2) Criterion A: Normal performance within the specification.
- 3) Criterion B: Temporary degradation or less of function of performance which is self recoverable.
- 4) Criterion C: Temporary degradation or less of function or perform. Which requires. Operate intervention or system reset.

Final Result: **PASSED**

Photos of test configuration please refer to APPENDIX 1.

Discharge points please refer below photos (Red dot: Contact; Blue dot: Air)

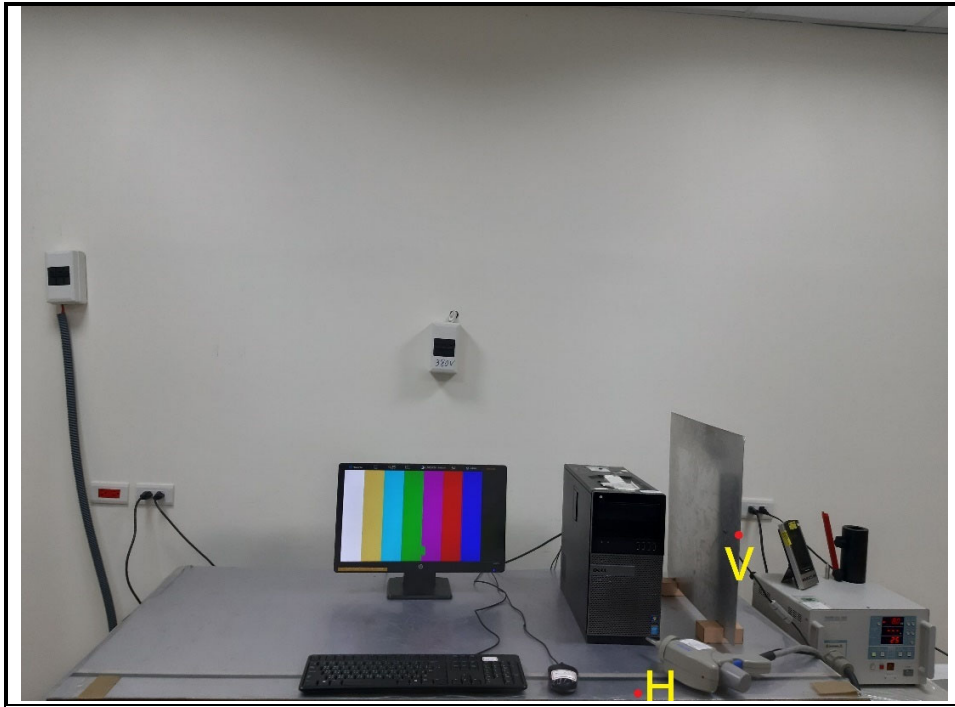





9. RADIATED SUSCEPTIBILITY MEASUREMENT (RS)

9.1 TEST SETUP

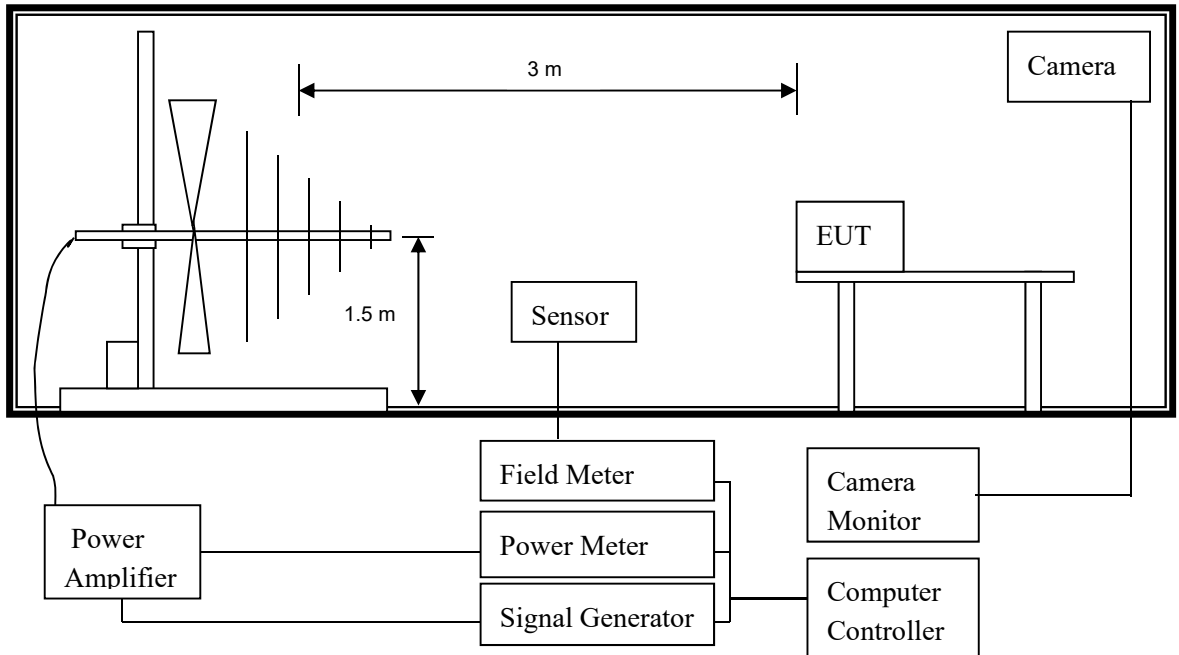

9.2 TEST SPECIFICATION

According to IEC 61000-4-3

(Please refer to Page 5 for dated references which are related to the standard as mentioned above)

9.3 TEST LEVEL

Item	Test Specification	Unit	Performance Criteria
Radio –Frequency	80~1000, 1800, 2600, 3500, 5000	MHz	A
Electromagnetic Field	3	V/m (unmodulated)	
Amplitude Modulated	80	%AM (1 kHz)	

9.4 TEST PROCEDURE

The EUT and load, which are placed on a wooden table whose height is 0.8 meter aboveground, are placed with one coincident with the calibration plane such that the distance from antenna to the EUT is 3 meters.



Both horizontal and vertical polarization of the antenna position and four sides of the EUT are set on measurement. In order to judge the EUT performance, a CCD camera is used to monitor the situation of EUT.

All the scanning conditions are as follows:

Condition of Test	
1. Field Strength	3 V/m
2. Radiated Signal	AM 80% modulated with 1 kHz
3. Scanning Frequencies	80 ~ 1000, 1800, 2600 ,3500, 5000 MHz
4. Dwell Time	3 seconds
5. Frequency step size	1%
6. Antenna Polarity	HORIZONTAL & VERTICAL
7. The four sides of EUT are tested	FRONT, REAR, RIGHT, LEFT

9.5 TEST RESULT:

Model Name	SX240-297
Test Voltage	DC 5V
Temperature:	25 °C
Humidity:	49 % RH

Polarity EUT Face	HORIZONTAL	VERTICAL	RESULT
FRONT	A	A	PASS
REAR	A	A	PASS
LEFT	A	A	PASS
RIGHT	A	A	PASS

Note:

- 1) "--": denotes test is not applicable.
- 2) Criterion A: Normal performance within the specification.
- 3) Criterion B: Temporary degradation or less of function of performance which is self recoverable.
- 4) Criterion C: Temporary degradation or less of function or perform. Which requires. Operate intervention or system reset.

Final Result: **PASSED**

Photos of test configuration please refer to APPENDIX 1.



10. ELECTRICAL FAST TRANSIENT/BURST (EFT)

10.1 TEST SETUP

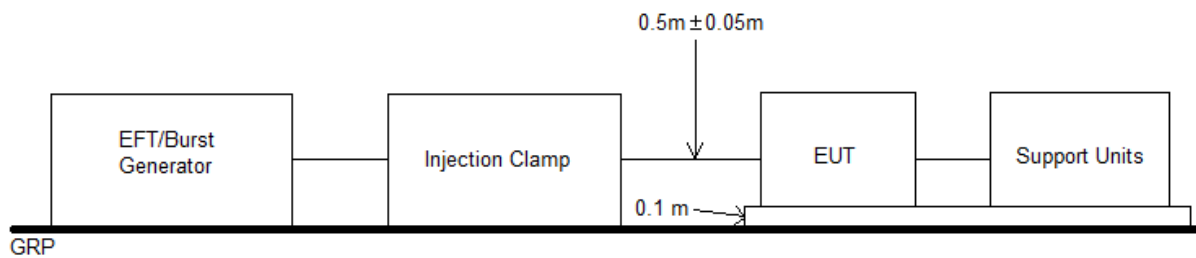
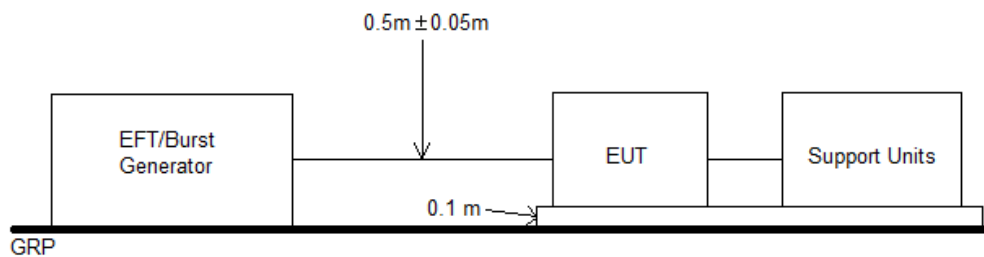

10.2 TEST SPECIFICATION

According to IEC 61000-4-4

(Please refer to Page 5 for dated references which are related to the standard as mentioned above)

10.3 TEST PROCEDURE

The EUT and load are placed on a ground reference plane and insulated from it by an insulating support $0,1\text{ m} \pm 0,01\text{ m}$ thick. The minimum area of the ground reference plane is $1\text{ m} \times 1\text{ m}$. It also projected beyond the EUT by at least 0.1 meter on all sides.

For Input and Output AC power or DC Input and DC Output Power Ports:

The EUT is connected with the power mains through a coupling device that directly couples the EFT interference signal.

Each of the line and nature conductors is impressed with burst noise for 1 minute.

For Protective Earth Port:



The EUT is connected to the power mains through a coupling device that directly couples the EFT interference signal. The protective earth line (PE) is impressed with burst noise for 1 minute.

The length of power cord between the coupling device and the EUT shall be $0.5\text{ m} \pm 0.05\text{ m}$.
For signal Lines and Control Lines Test:

The EFT interference signal is through a coupling clamp device couples to the signal and control lines of the EUT with burst noise for 1 minute.

10.4 TEST LEVEL

Item	Test Specification	Unit	Performance Criteria
Test Voltage	AC port: $\pm 0.5, \pm 1$ DC/Signal port: ± 0.5	kV (Peak)	B
Impulse Wave-shape	5/50	ns (Tr/Ts)	
Repetition frequency	5	kHz	
Burst Duration	15	ms	
Burst Period	300	ms	
Test Duration	Not less than 1	mins	

10.5 TEST RESULT

Model Name	SX240-297
Test Voltage	DC 5V
Temperature:	25 °C
Humidity:	49 % RH

Test Point/ Mode / Result		0.5 kV		1 kV		2 kV	
		+	-	+	-	+	-
Power Line	L	A	A	A	A	--	--
	N	A	A	A	A	--	--
	L+N	A	A	A	A	--	--
	PE	A	A	A	A	--	--
	L+PE	A	A	A	A	--	--
	N+PE	A	A	A	A	--	--
	L+N+PE	A	A	A	A	--	--
Signal Line Clamp Test		--	--	--	--	--	--

Note:



- 1) "--": denotes test is not applicable.
- 2) Criterion A: Normal performance within the specification.
- 3) Criterion B: Temporary degradation or less of function of performance which is self recoverable.
- 4) Criterion C: Temporary degradation or less of function or perform. Which requires. Operate intervention or system reset.

Final Result: **PASSED**

Photos of test configuration please refer to APPENDIX 1.



11. SURGE

11.1 TEST SETUP

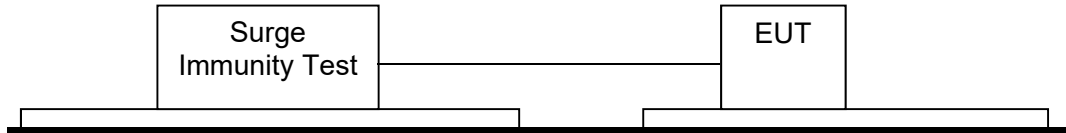

11.2 TEST SPECIFICATION

According to IEC 61000-4-5

(Please refer to Page 5 for dated references which are related to the standard as mentioned above)

11.3 TEST LEVEL

Item	Test Specification	Unit	Performance Criteria
DC Input and DC Output Power Ports			
Surge	1.2/50(8/20)	Tr/Ts (μs)	
Line to Ground	±0.5	kV	B
Line to Line	±0.5	kV	B
AC Input and AC Output Power Ports			
Surge	1.2/50(8/20)	Tr/Ts (μs)	
Line to Ground	±0.5, ±1, ±2	kV	B
Line to Line	±0.5, ±1	kV	B
Signal Ports			
Surge	10/700	Tr/Ts (μs)	
Line to Ground	±0.5, ±1	kV	C
Polarity	POSITIVE / NEGATIVE		
Pulse Repetition Rate	1 time / min (maximum)		

11.4 TEST PROCEDURE

The length of power cord between the coupling device and the EUT shall be 2 meters or less.

For Input and Output AC Power or DC Input and DC Output Power Ports:



The EUT is connected to the power mains through a coupling device that directly couples the Surge interference signal.

The Surge noise shall be applied synchronized to the voltage phase at 0°, 90°, 180°, 270° and the peak value of the AC voltage wave. (5 Positive and 5 Negative)

Each of line-earth and line-line is impressed with a sequence of five surge voltages with interval of 1 minute.

11.5 TEST RESULT

Model Name	SX240-297
Test Voltage	DC 5V
Temperature:	25 °C
Humidity:	49 % RH

Power Port	Waveform: 1.2/50µs(8/20µs)		
Phase/Polarity/Mode/Result			Result
0.5 kV, 1 kV	+	Line to Neutral	A
	-		A
0.5 kV, 1 kV, 2 kV	+	Line to Ground	A
	-		A
	+	Neutral to Ground	A
	-		A
Signal Port	Waveform: 10/700µs		
Phase/Polarity/Mode			Result
0.5 kV, 1 kV	+	Line to Ground	--
	-		--

Note:

- 1) "--": denotes test is not applicable.
- 2) Criterion A: Normal performance within the specification.
- 3) Criterion B: Temporary degradation or less of function of performance which is self recoverable.
- 4) Criterion C: Temporary degradation or less of function or perform. Which requires. Operate intervention or system reset.

Final Result: **PASSED**

Photos of test configuration please refer to APPENDIX 1.



12. IMMUNITY TEST TO CS CONDUCTED DISTURBANCE (CS)

12.1 TEST SETUP

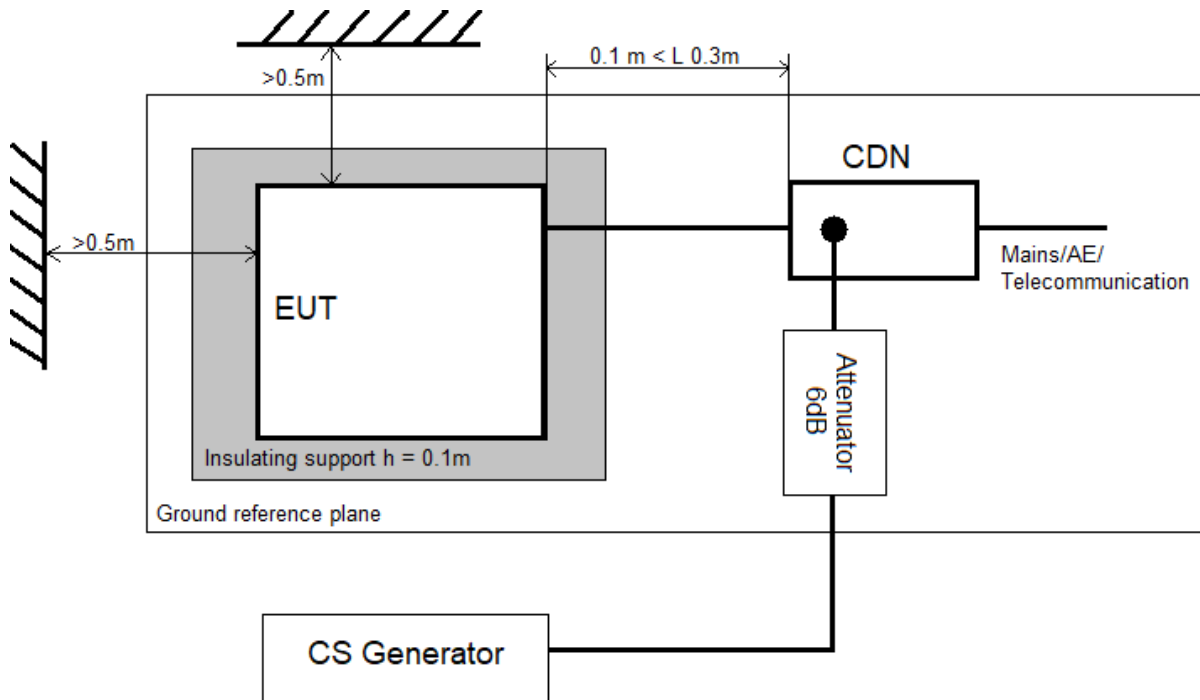

12.2 TEST SPECIFICATION

According to IEC 61000-4-6

(Please refer to Page 5 for dated references which are related to the standard as mentioned above)

12.3 TEST LEVEL

Item	Test Specification	Unit	Performance Criteria
Signal Port			
Frequency Range	0.15 ~ 80	MHz	A
Field Strength	3	Vrms (unmodulated)	
Amplitude Modulated	80	%AM (1 kHz)	
AC Input and AC Output and DC Input and DC output Ports and Functional Earth Ports			
Frequency Range	0.15 ~ 80	MHz	A
Field Strength	3	Vrms (unmodulated)	
Amplitude Modulated	80	%AM (1 kHz)	



12.4 TEST PROCEDURE

The EUT are placed upon table and use 10cm insulation between the EUT and ground reference plane.

For AC Input and AC Output Power or DC Input and DC Output Power Ports:

The EUT is connected to the power mains through a coupling and decoupling network for Power supply lines. It also directly couples the disturbance signal into EUT.

Use CDN-M2 for two wires or CDN-M3 for three wires.

For Signal Lines and Control Lines Test:

The disturbance signal is through a coupling and decoupling networks (CDN) or EM-clamp which is to couple the signal and control lines of the EUT.

All scanning frequencies conditions are as following:

Condition of Test	
1. Field Strength	3 V
2. Radiated Signal	AM 80% modulated with 1 kHz
3. Scanning Frequencies	0.15 MHz ~ 80 MHz
4. Dwell Time	3 seconds
5. Frequency step size	1%
6. The rate of swept of frequency	1.5 x 10 ⁻³ decades/s

12.5 TEST RESULT

Model Name	SX240-297
Test Voltage	DC 5V
Temperature:	25 °C
Humidity:	49 % RH

Test Ports	Frequency Range (MHz)	Field Strength (Vrms)	Result
Power Port	0.15 – 80	3	A
Signal Port	0.15 – 80	3	--

Note:

- 1) "--": denotes test is not applicable.
- 2) Criterion A: Normal performance within the specification.
- 3) Criterion B: Temporary degradation or less of function of performance which is self recoverable.
- 4) Criterion C: Temporary degradation or less of function or perform. Which requires. Operate intervention or system reset.

Final Result: **PASSED**

Photos of test configuration please refer to APPENDIX 1.



13. POWER FREQUENCY MAGNETIC FIELD (PFMF)

13.1 TEST SETUP

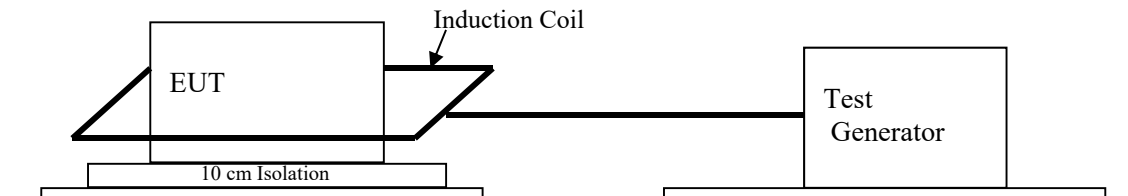

13.2 TEST SPECIFICATION

According to IEC 61000-4-8

(Please refer to Page 5 for dated references which are related to the standard as mentioned above)

13.3 TEST LEVEL

Item	Test Specification	Unit	Performance Criteria
Power-Frequency	50/60	Hz	A
Magnetic Field	1	A/m	
Observation Time	1	min	
Inductance Coil	1x1 (Rectangular type)	m	

13.4 TEST PROCEDURE

The inductive coil is at least 1 meter x 1 meter, and 0.65mm minimum thickness.

The test magnetic field shall be applied by the immersion method to the EUT, and all cables shall be exposed to the magnetic field for 1 m of their length.

The induction coil shall be rotated by 90° in order to expose the EUT to the test field with different orientation (X, Y, Z orientation).

13.5 TEST RESULT

Model Name	SX240-297
Test Voltage	DC 5V
Temperature:	25 °C
Humidity:	49 % RH



Direction	Field Strength (A/m)	Duration (s)	Result
X	1	60	A
Y	1	60	A
Z	1	60	A

Note:

- 1) "--": denotes test is not applicable.
- 2) Criterion A: Normal performance within the specification.
- 3) Criterion B: Temporary degradation or less of function of performance which is self recoverable.
- 4) Criterion C: Temporary degradation or less of function or perform. Which requires. Operate intervention or system reset.

Final Result: **PASSED**

Photos of test configuration please refer to APPENDIX 1.



14. VOLTAGE DIPS AND INTERRUPTION MEASUREMENT(DIPS)

14.1 TEST SETUP

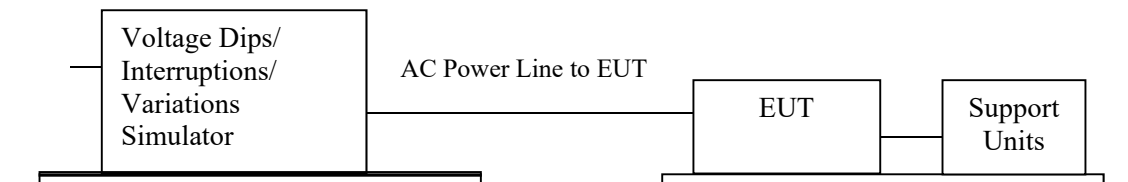

14.2 TEST SPECIFICATION

According to IEC 61000-4-11

(Please refer to Page 5 for dated references which are related to the standard as mentioned above)

14.3 TEST LEVEL

Class ^a	Test level and durations for voltage dips				
Class 1	Case-by-case according to the equipment requirements				
Class 2	0 % during 1/2 cycle	0 % during 1 cycle	70 % during 25/30 ^c cycles		
Class 3	0 % during 1/2 cycle	0 % during 1 cycle	40 % during 10/12 ^c cycles	70 % during 25/30 ^c cycles	80 % during 250/300 ^c cycles
Class X ^b	X	X	X	X	X

a: Classes as per IEC 61000-2-4.

b: To be defined by product committee. For equipment connected directly or indirectly to the public network, the levels must not be less severe than Class 2.

c: "25/30 cycles" means "25 cycles for 50 Hz test" and "30 cycles for 60 Hz test".

Class ^a	Test level and durations for short interruptions (t _s) (50Hz / 60Hz)
Class 1	Case-by-case according to the equipment requirements
Class 2	0 % during 250/300 ^c cycles
Class 3	0 % during 250/300 ^c cycles
Class X ^b	X

a: Classes as per IEC 61000-2-4.

b: To be defined by product committee. For equipment connected directly or indirectly to the public network, the levels must not be less severe than Class 2.

c: "250/300 cycles" means "250 cycles for 50 Hz test" and "300 cycles for 60 Hz test".



14.4 TEST PROCEDURE

The power cord shall be used the shortest power cord as specified by the manufacturer.

For Voltage Dips / Interruption Test:

The EUT is connected to the power mains through a coupling device that directly couples to the Voltage Dips and Interruption Generator.

The EUT shall be tested for 95% voltage dips of supplied voltage and duration time is 10ms, for 30% voltage dips of supplied voltage and duration time is 500ms with a sequence of three voltage dips with intervals of 10 seconds, and for 95% voltage interruption of supplied voltage and the duration time is 5000ms with a sequence of three voltage interruptions with intervals of 10 seconds.

Voltage phase shifting are shall occur at 0°, 45°, 90°, 135°, 180°, 225°, 270°, 315° of the voltage.

14.5 TEST RESULT

Model Name	SX240-297
Test Voltage	DC 5V
Temperature:	25 °C
Humidity:	49 % RH

Voltage Dips	Test Level % U _T	Reduction (%)	Duration	Performance Criteria
	<5	>95	0.5 (periods)	B
	70	30	25 (periods)	C

Voltage Interruptions	Test Level % U _T	Reduction (%)	Duration	Performance Criteria
	<5	>95	250 (periods)	C

Note:

- 1) "--": denotes test is not applicable.
- 2) Criterion A: Normal performance within the specification.
- 3) Criterion B: Temporary degradation or less of function of performance which is self recoverable.
- 4) Criterion C: Temporary degradation or less of function or perform. Which requires. Operate intervention or system reset.

Final Result: **PASSED**

Please refer to APPENDIX 1.



15. MEASUREMENT UNCERTAINTY

Measurement Item	Measurement Frequency	Polarization	Uncertainty
Conducted Emission	9 kHz ~ 30 MHz	LINE/NEUTRAL	3.54 dB
Conducted Emission at telecommunication ports	150 kHz ~ 30 MHz	/	3.36 dB
Radiated Emission	Below 1GHz	Horizontal	2.81 dB
		Vertical	4.01 dB
	Above 1GHz	Horizontal	4.64 dB
		Vertical	5.16 dB

Measurement Item	Uncertainty	
Harmonic/Flicker emissions	Harmonic	0.54 %
	Voltage	0.5 %
	Flicker	4.96 %



APPENDIX 1
PHOTOS OF TEST CONFIGURATION
Conducted Emission Test Setup





Radiated Emission Test Setup





ESD Test Setup



RS Test Setup





EFT & Surge Test Setup



CS Test Setup

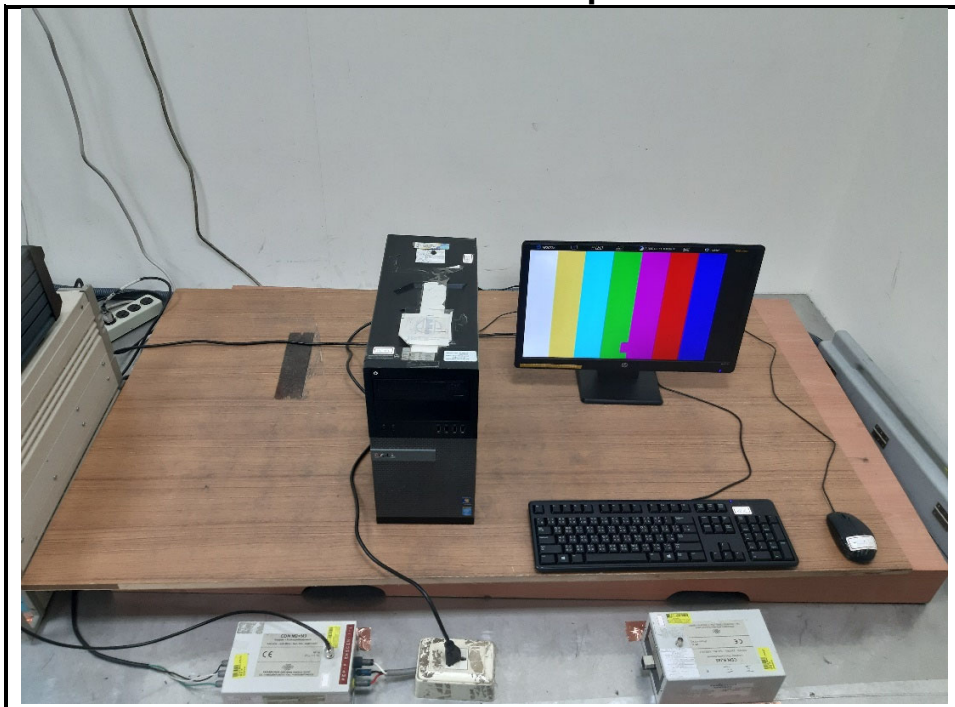



PFMF Test Setup



DIPS Test Setup





Power Harmonic / Voltage Fluctuations Test Setup

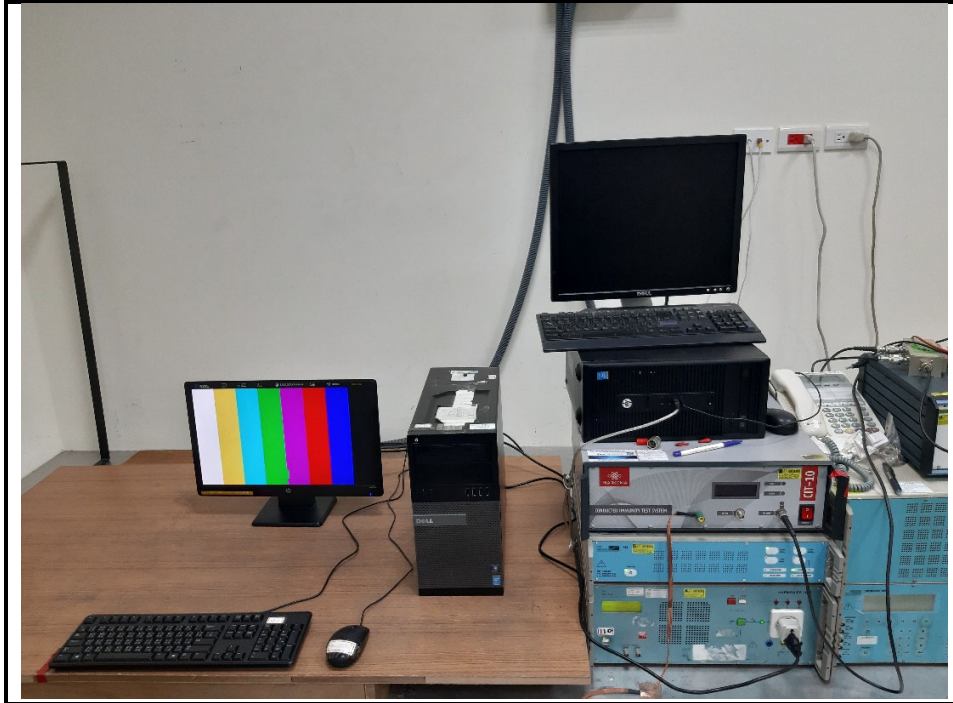



APPENDIX 2
TEST DATA
Test Data – Conducted Emission

Phase: L

Data: 1

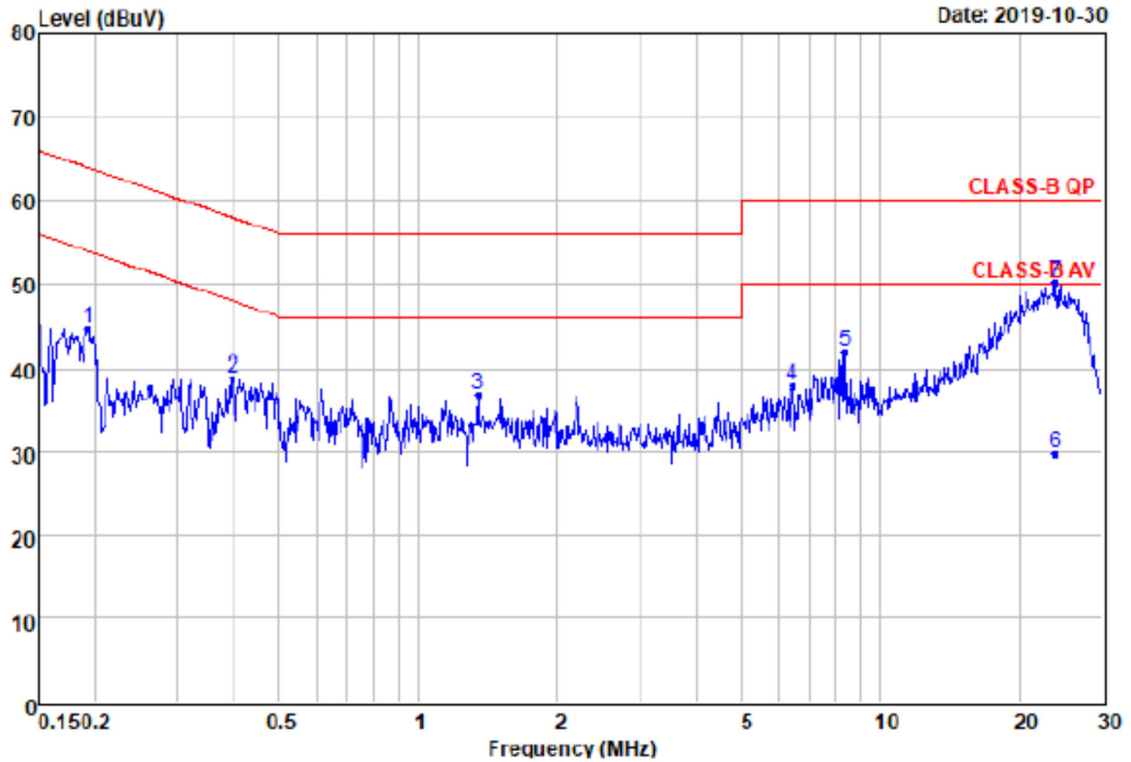

Remarks	: Factor=Insertion loss+Cable loss						
	Read	Level	Factor	Over	Limit	Line	Remark
	Level	Level		Limit	Limit		
	dBuV	dBuV	dB	dB	dBuV		
1	34.46	44.53	10.07	-19.40	63.93		Peak
2	28.84	38.92	10.08	-19.03	57.95		Peak
3	26.73	36.86	10.13	-19.14	56.00		Peak
4	27.61	37.90	10.29	-22.10	60.00		Peak
5	31.49	41.83	10.34	-18.17	60.00		Peak
6	19.20	29.85	10.65	-20.15	50.00		Average
7 @	39.59	50.24	10.65	-9.76	60.00		Peak



Phase: N

Data: 2

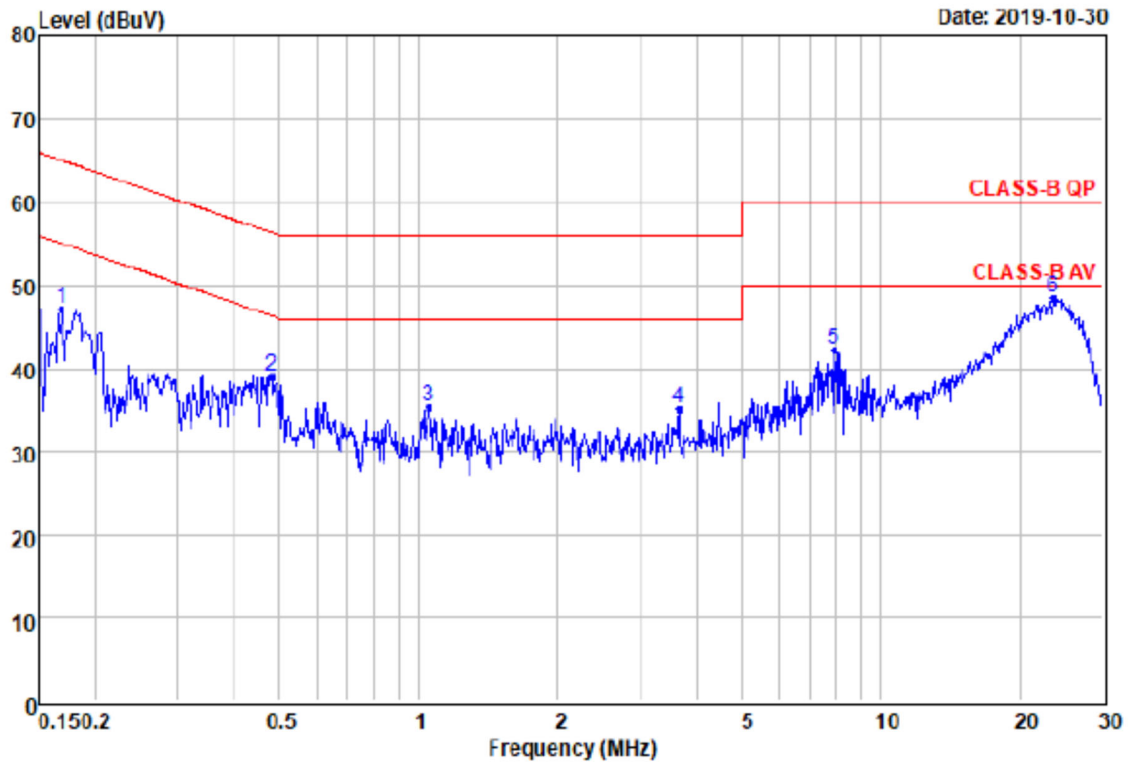

Remarks : Factor=Insertion loss+Cable loss

	Read	Over	Limit	Line	Remark	
Freq	Level	Level	Factor	Limit		
MHz	dBuV	dBuV	dB	dB	dBuV	
1	0.17	37.09	47.15	10.06	-17.88	65.03 Peak
2	0.48	29.02	39.09	10.07	-17.27	56.36 Peak
3	1.05	25.36	35.46	10.10	-20.54	56.00 Peak
4	3.64	24.91	35.11	10.20	-20.89	56.00 Peak
5	7.89	31.97	42.27	10.30	-17.73	60.00 Peak
6 @	23.51	37.83	48.41	10.58	-11.59	60.00 Peak



Test Data – Radiated Emission-Below 1GHz

Polarization: Horizontal

Data: 1

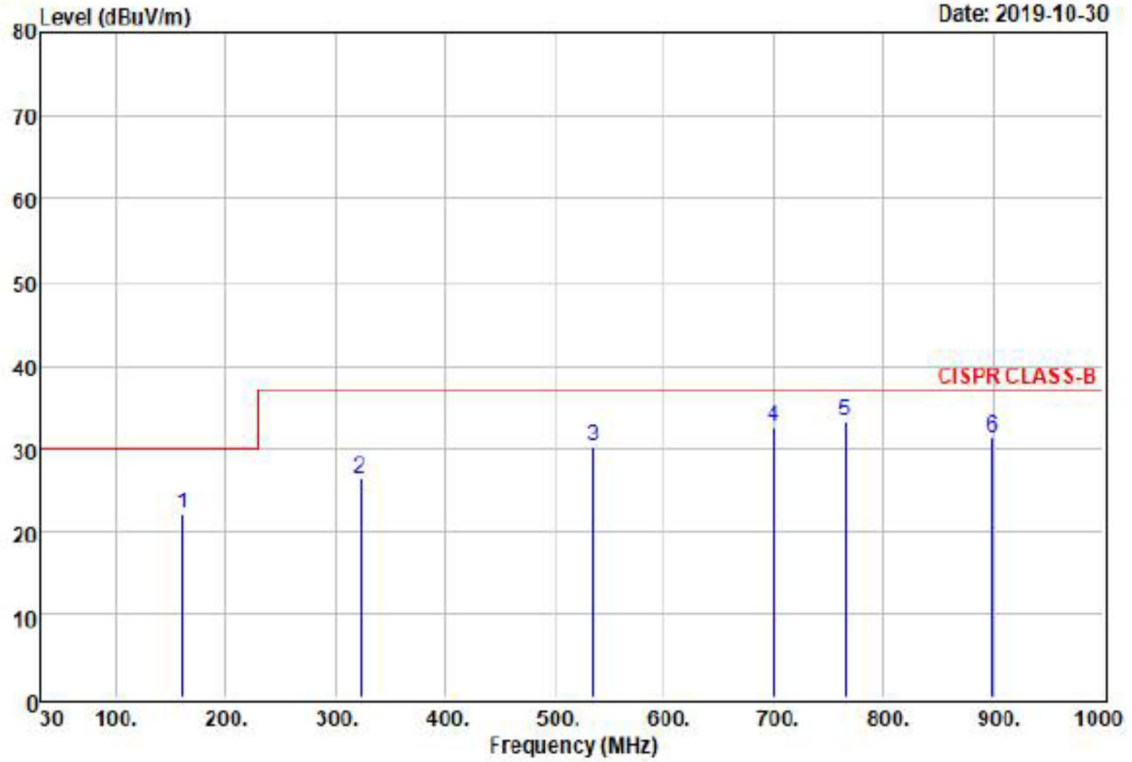

Remarks

- : 1.Result=Read Value+Factor
- : 2.Factor=Antenna Factor+Cable loss-
: Amplifier Factor

	Freq	Level	Read Level	Over Limit	Limit	Remark
	MHz	dBuV/m	dBuV	dB	dBuV/m	
1	160.30	22.18	39.09	-16.91	30.00	QP
2	322.40	26.39	39.28	-12.89	37.00	QP
3	534.60	30.19	38.84	-8.65	37.00	QP
4	700.40	32.55	39.45	-6.90	37.00	QP
5 @	765.40	33.21	39.22	-6.01	37.00	QP
6	899.30	31.33	34.94	-3.61	37.00	QP



Polarization: Vertical

Data: 2

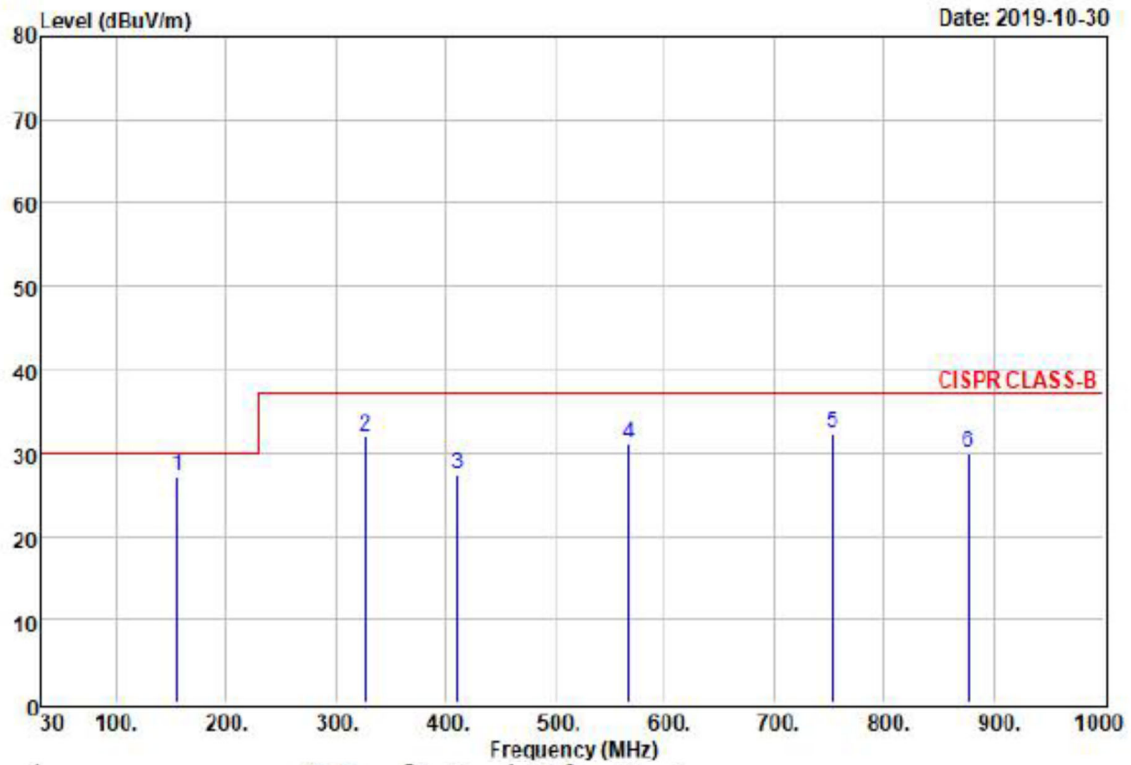

Remarks

- : 1.Result=Read Value+Factor
- : 2.Factor=Antenna Factor+Cable loss-
: Amplifier Factor

	Freq	Level	Read Level	Over Limit	Limit	Remark
	MHz	dBuV/m	dBuV	dB	dBuV/m	
1 @	155.60	27.26	43.45	-16.19	-2.74	30.00 QP
2	327.60	31.97	44.63	-12.66	-5.03	37.00 QP
3	411.20	27.43	37.90	-10.47	-9.57	37.00 QP
4	567.50	31.13	40.14	-9.01	-5.87	37.00 QP
5	753.20	32.46	38.65	-6.19	-4.54	37.00 QP
6	877.50	30.03	33.78	-3.75	-6.97	37.00 QP



Test Data – Radiated Emission- 1GHz-6GHz

Polarization: Horizontal

Data: 1

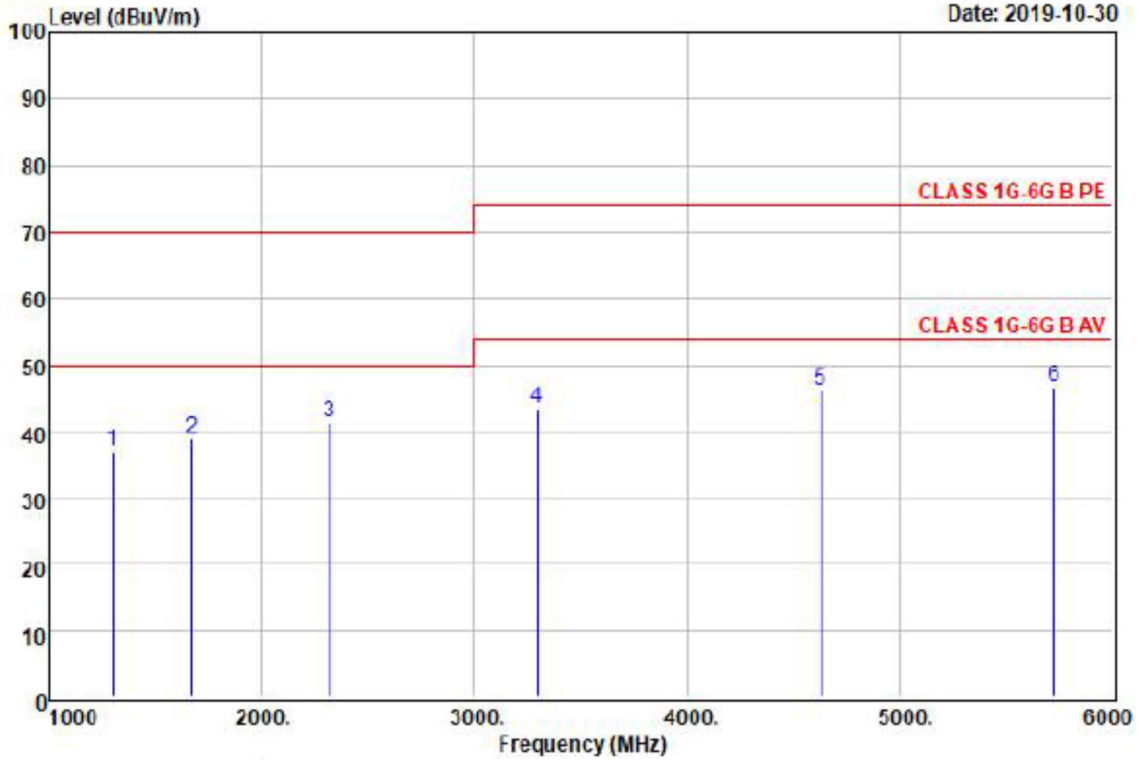

Remarks : 1.Result=Read Value+Factor
: 2.Factor=Antenna Factor+Cable loss-
: Amplifier Factor

	Freq	Level	Read Level	Factor	Over Limit	Limit	Remark
	MHz	dBuV/m	dBuV	dB/m	dB	dBuV/m	
1	1299.00	36.88	56.15	-19.27	-33.12	70.00	Peak
2	1674.00	38.88	57.37	-18.49	-31.12	70.00	Peak
3	2323.00	41.35	56.30	-14.95	-28.65	70.00	Peak
4	3297.00	43.55	53.94	-10.39	-30.45	74.00	Peak
5	4629.00	45.99	54.71	-8.72	-28.01	74.00	Peak
6 @	5724.00	46.56	52.50	-5.94	-27.44	74.00	Peak



Polarization: Vertical

Data: 2

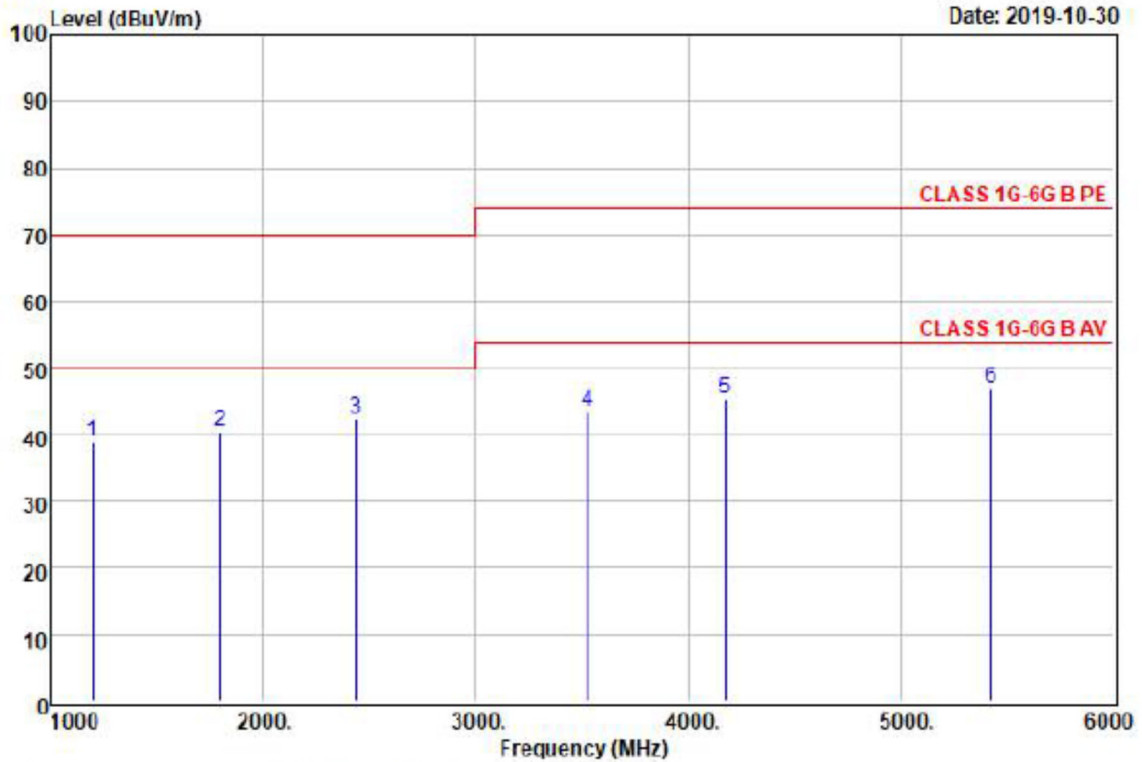

Remarks : 1.Result=Read Value+Factor
: 2.Factor=Antenna Factor+Cable loss-
: Amplifier Factor

	Freq	Level	Read Level	Factor	Over Limit	Limit Line	Remark
	MHz	dBuV/m	dBuV	dB/m	dB	dBuV/m	
1	1200.00	39.00	59.46	-20.46	-31.00	70.00	Peak
2	1800.00	40.55	58.47	-17.92	-29.45	70.00	Peak
3	2440.00	42.23	56.85	-14.62	-27.77	70.00	Peak
4	3527.00	43.56	54.82	-11.26	-30.44	74.00	Peak
5	4177.00	45.24	55.80	-10.56	-28.76	74.00	Peak
6 @	5423.00	46.85	54.24	-7.39	-27.15	74.00	Peak



Test Data – Power Harmonic

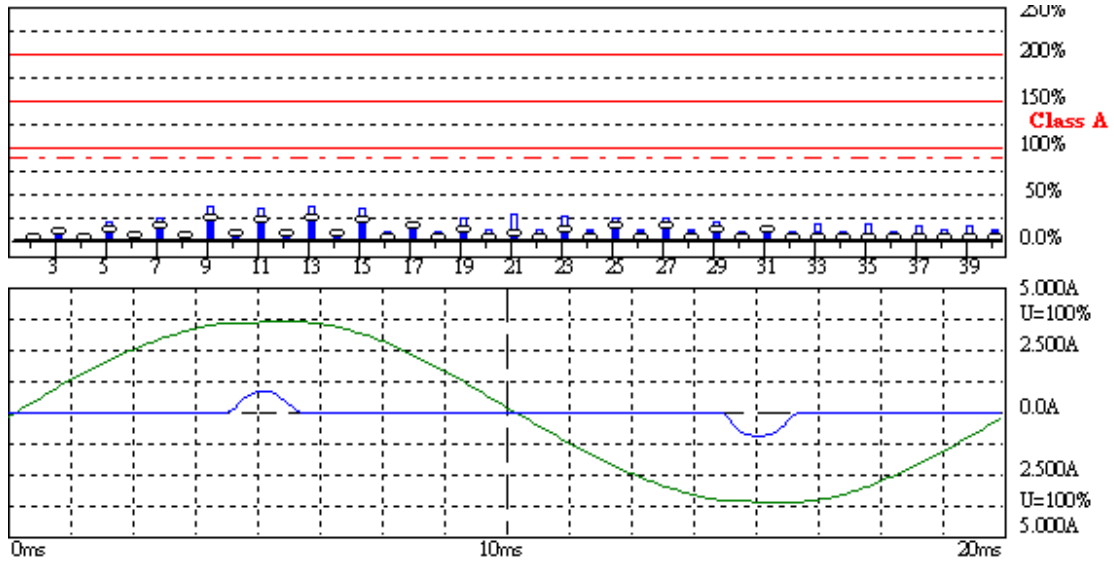

Harmonic Emission - IEC 61000-3-2 , EN 61000-3-2 , (EN60555-2)

2019/7/22 PM 01:57:1

U_{rms} = 228.9 V P = 27.49 W THC = 0.224 A
I_{rms} = 0.259 A pf = 0.464

Range: 5 A
V_{nom}: 230 V
TestTime: 5 min (100%)

23

Test completed, Result: PASSED

Att22

HAR-1000 EMC-Printer



WH Technology Corp.

Date : 2019/10/30 PM 01:57:1 V4.22

EUT : 19071701
Temperature : 23
Humidity : 47
Tester : Anna

Urms = 228.9V Freq = 49.922 Range: 5 A
Irms = 0.259A Ipk = 1.023A cf = 3.953
P = 27.49W S = 59.24VA pf = 0.464
THDi = 181 % THDu = 1.70 % Class A

Test - Time : 5min (100 %)

Test completed, Result: PASSED

Order	Freq. [Hz]	Iavg [A]	Imax [A]	Limit [A]	Status	Vrms [V]	Limit [V]
1	50	0.1410	0.2359			228.83	0.0000
2	100	0.0087	0.0134	1.0800		0.4418	0.4663
3	150	0.1349	0.2194	2.3000		2.8960	2.0615
4	200	0.0091	0.0143	0.4300		0.3436	0.4663
5	250	0.1231	0.1935	1.1400		1.7670	0.9081
6	300	0.0089	0.0140	0.3000		0.1963	0.4663
7	350	0.1068	0.1682	0.7700		1.0799	0.6872
8	400	0.0087	0.0137	0.2300		0.0736	0.4663
9	450	0.0876	0.1385	0.4000		0.8835	0.4663
10	500	0.0079	0.0125	0.1840		0.1473	0.4663
11	550	0.0672	0.1068	0.3300		0.4172	0.2209
12	600	0.0070	0.0110	0.1533		0.1227	0.2209
13	650	0.0472	0.0754	0.2100		0.3436	0.2209
14	700	0.0057	0.0092	0.1314		0.0245	0.2209
15	750	0.0294	0.0467	0.1500		0.0736	0.2209
16	800	0.0014	0.0076	0.1150		0.0245	0.2209
17	850	0.0169	0.0229	0.1324		0.0736	0.2209
18	900	0.0012	0.0070	0.1022		0.0245	0.2209
19	950	0.0095	0.0262	0.1184		0.2209	0.2209
20	1000	0.0013	0.0073	0.0920		0.0000	0.2209
21	1050	0.0051	0.0272	0.1071		0.0491	0.2209
22	1100	0.0014	0.0076	0.0836		0.0245	0.2209
23	1150	0.0104	0.0232	0.0978		0.1227	0.2209
24	1200	0.0014	0.0076	0.0767		0.0736	0.2209



25	1250	0.0115	0.0195	0.0900	0.0736	0.2209
26	1300	0.0000	0.0067	0.0708	0.0736	0.2209
27	1350	0.0106	0.0177	0.0833	0.0000	0.2209
28	1400	0.0000	0.0055	0.0657	0.0491	0.2209
29	1450	0.0082	0.0137	0.0776	0.0245	0.2209
30	1500	0.0000	0.0040	0.0613	0.0491	0.2209
31	1550	0.0064	0.0089	0.0726	0.0736	0.2209
32	1600	0.0000	0.0040	0.0575	0.0245	0.2209
33	1650	0.0013	0.0107	0.0682	0.0245	0.2209
34	1700	0.0000	0.0034	0.0541	0.0491	0.2209
35	1750	0.0014	0.0098	0.0643	0.0736	0.2209
36	1800	0.0000	0.0034	0.0511	0.0491	0.2209
37	1850	0.0013	0.0076	0.0608	0.0000	0.2209
38	1900	0.0000	0.0040	0.0484	0.0245	0.2209
39	1950	0.0008	0.0073	0.0577	0.0000	0.2209
40	2000	0.0000	0.0049	0.0460	0.0491	0.2209

Important:

- without Interharmonics
- 100% of time voltage "out of Spec"



Test Data – Voltage Fluctuations

Flicker Emission IEC 61000-4-15 for 230V/50Hz

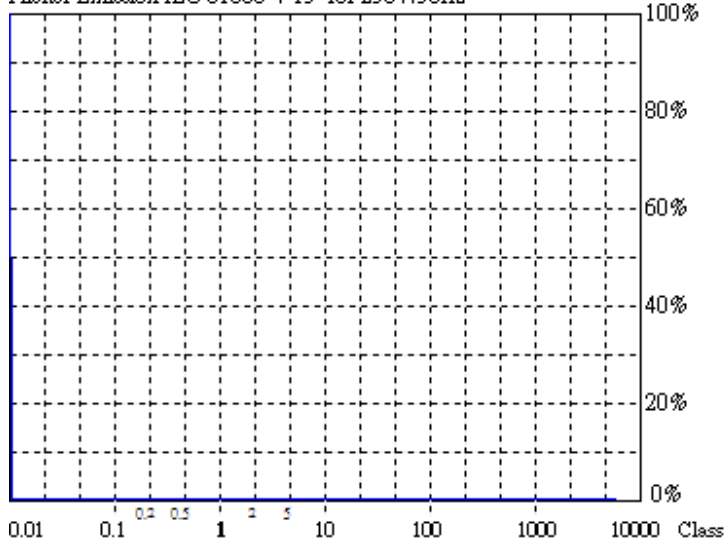

Actual Flicker (Fli):	0.00
Short-term Flicker (Pst):	0.07
Limit (Pst):	1.00
Long-term Flicker (Plt):	0.07
Limit (Plt):	0.65
Maximum Relative Volt. Change (dmax):	0.00%
Limit (dmax):	4.00%
Relative Steady-state Voltage Change (dc):	0.19%
Limit (dc):	3.30%
Tmax 3.30% (dt):	0.00ms
Limit (dt>Lim):	500ms

Flicker Emission - IEC 61000-3-3 , EN 61000-3-3

2019/7/22 PM 02:16:2

U_{rms} = 228.9 V P = 27.00 W
I_{rms} = 0.251 A pf = 0.469

Range: 5 A
V_{nom}: 230 V
TestTime: 10 min (100%)

23

Test completed, Result: PASSED

Attnz

HAR-1000 EMC-Report



WH Technology Corp.

Date : 2019/10/30 PM 02:16:2 V4.22

EUT : 19071701
Temperature : 23
Humidity : 47
Tester : Anna

Urms = 228.9V Freq = 49.922 Range: 5 A
Irms = 0.251A Ipk = 1.021A cf = 4.058
P = 27.00W S = 57.57VA pf = 0.469

Test - Time : 1 x 10min = 10min (100 %)

LIN (Line Impedance Network) : L: 0.24ohm +j0.15ohm N: 0.16ohm +j0.10ohm

Limits : Plt : 0.65 Pst : 1.00
dmax : 4.00 % dc : 3.30 %
dtLim: 3.30 % dt>Lim: 500ms

Test completed, Result: PASSED

Plt = 0.072

	Pst	dmax	dc	dt>Lim
		[%]	[%]	[ms]
1	0.072	0.000	0.190	0.000



PHOTOS OF EUT

