

Certificate

Issue Date: December 26, 2014
Ref. Report No. ISL-14LE536CE

Product Name : HalfSlim SSD
Model(s) : SFD18SH/-M/-MK
Brand : Apacer
Responsible Party : Apacer Technology Inc.
Address : 1F., No.32, Zhongcheng Rd., Tucheng Dist., New Taipei City 236, Taiwan , R.O.C.

We, **International Standards Laboratory**, hereby certify that:

The device bearing the trade name and model specified above has been shown to comply with the applicable technical standards as indicated in the measurement report and was tested in accordance with the measurement procedures specified in European Council Directive- EMC Directive 2004/108/EC. The device was passed the test performed according to :

Standards:



EN 55022: 2010+AC2011 and CISPR 22: 2008 (modified)
EN 61000-3-2: 2006+A1:2009 +A2:2009 and IEC 61000-3-2: 2005+A1:2008 +A2:2009
EN 61000-3-3: 2013 and IEC 61000-3-3: 2013
EN 55024: 2010 and CISPR 24: 2010
EN 61000-4-2: 2009 and IEC 61000-4-2: 2008
EN 61000-4-3: 2006+A1: 2008 +A2: 2010 and IEC 61000-4-3:2006+A1: 2007+A2: 2010
EN 61000-4-4:2012 and IEC 61000-4-4:2012
EN 61000-4-5: 2006 and IEC 61000-4-5: 2005
EN 61000-4-6: 2009 and IEC 61000-4-6: 2008
EN 61000-4-8: 2010 and IEC 61000-4-8: 2009
EN 61000-4-11: 2004 and IEC 61000-4-11: 2004

I attest to the accuracy of data and all measurements reported herein were performed by me or were made under my supervision and are correct to the best of my knowledge and belief. I assume full responsibility for the completeness of these measurements and vouch for the qualifications of all persons taking them.

International Standards Laboratory

Jim Chu
Jim Chu / Director

Hsi-Chih LAB:

No. 65, Gu Dai Keng Street, Hsi-Chih Dist.,
New Taipei City 221, Taiwan
Tel: 886-2-2646-2550; Fax: 886-2-2646-4641



Lung-Tan LAB:

No. 120, Lane 180, San Ho Tsuen, Hsin Ho Rd.,
Lung-Tan Hsiang, Tao Yuan County 325, Taiwan
Tel: 886-3-407-1718; Fax: 886-3407-1738



CE MARK TECHNICAL FILE

AS/NZS EMC CONSTRUCTION FILE

of

Product Name

HalfSlim SSD

Model

SFD18SH/-M/-MK

Brand

Apacer

Contains:

1. Declaration of Conformity
2. EN55022/CISPR 22, AS/NZS CISPR 22 EMI test report
3. EN55024/CISPR 24, EN61000-3-2 / IEC 61000-3-2, and EN61000-3-3 / IEC 61000-3-3 test report
4. Block Diagram and Schematics
5. Users' manual

Declaration of Conformity

Name of Responsible Party: Apacer Technology Inc.
 Address of Responsible Party: 1F., No.32, Zhongcheng Rd., Tucheng Dist.,
 New Taipei City 236, Taiwan , R.O.C.
 Declares that product: HalfSlim SSD
 Model: SFD18SH/-M/-MK
 Brand: Apacer
 Assembled by: Same as above
 Address: Same as above

Conforms to the EMC Directive 2004/108/EC as attested by conformity with the following harmonized standards:

EN 55022:2010+AC:2011, CISPR 22:2008 (modified) and AS/NZS CISPR 22:2009+A1:2010: Limits and methods of measurement of Radio Interference characteristics of Information Technology Equipment.

EN 55024:2010 and CISPR 24:2010: Information technology equipment-Immunity characteristics - Limits and methods of measurement.

Standard	Description	Results	Criteria
EN 61000-4-2:2009 IEC 61000-4-2:2008	Electrostatic Discharge	Pass	B
EN 61000-4-3:2006+A1:2008 +A2:2010 IEC 61000-4-3:2006+A1:2007+A2:2010	Radio-Frequency, Electromagnetic Field	Pass	A
EN 61000-4-4:2012 IEC 61000-4-4:2012	Electrical Fast Transient/Burst	Pass	B
EN 61000-4-5:2006 IEC 61000-4-5:2005	Surge	Pass	B
EN 61000-4-6:2009 IEC 61000-4-6:2008	Conductive Disturbance	Pass	A
EN 61000-4-8:2010 IEC 61000-4-8:2009	Power Frequency Magnetic Field	Pass	A
EN 61000-4-11:2004 IEC 61000-4-11:2004	Voltage Dips / Short Interruption and Voltage Variation		
	>95% in 0.5 period	Pass	B
	30% in 25 period	Pass	C
	>95% in 250 period	Pass	C

Standard	Description	Results
EN 61000-3-2:2006 +A1:2009 +A2:2009 IEC 61000-3-2:2005 +A1:2008 +A2:2009	Limits for harmonics current emissions	Pass
EN 61000-3-3:2013 IEC 61000-3-3:2013	Limits for voltage fluctuations and flicker in low-voltage supply systems.	Pass

<to be continued>

We, Apacer Technology Inc., hereby declare that the equipment bearing the trade name and model number specified above was tested conforming to the applicable Rules under the most accurate measurement standards possible, and that all the necessary steps have been taken and are in force to assure that production units of the same equipment will continue to comply with the requirements.

Sheng-Wei Yu
Apacer Technology Inc.

Date: December 26, 2014

ISL
Draft

Declaration of Conformity

Name of Responsible Party: Apacer Technology Inc.
 Address of Responsible Party: 1F., No.32, Zhongcheng Rd., Tucheng Dist.,
 New Taipei City 236, Taiwan , R.O.C.
 Declares that product: HalfSlim SSD
 Model: SFD18SH/-M/-MK
 Brand: Apacer
 Assembled by: Same as above
 Address: Same as above

Conforms to the EMI part of RCM Mark requirements as attested by conformity with the following standards:

EN 55022:2010+AC:2011, CISPR 22:2008 (modified) and AS/NZS CISPR 22:2009+A1:2010: Limits and methods of measurement of Radio Interference characteristics of Information Technology Equipment.
 EN 55024:2010 and CISPR 24:2010: Information technology equipment-Immunity characteristics - Limits and methods of measurement.

Standard	Description	Results	Criteria
EN 61000-4-2:2009 IEC 61000-4-2:2008	Electrostatic Discharge	Pass	B
EN 61000-4-3:2006+A1:2008 +A2:2010 IEC 61000-4-3:2006+A1:2007+A2:2010	Radio-Frequency, Electromagnetic Field	Pass	A
EN 61000-4-4:2012 IEC 61000-4-4:2012	Electrical Fast Transient/Burst	Pass	B
EN 61000-4-5:2006 IEC 61000-4-5:2005	Surge	Pass	B
EN 61000-4-6:2009 IEC 61000-4-6:2008	Conductive Disturbance	Pass	A
EN 61000-4-8:2010 IEC 61000-4-8:2009	Power Frequency Magnetic Field	Pass	A
EN 61000-4-11:2004 IEC 61000-4-11:2004	Voltage Dips / Short Interruption and Voltage Variation		
	>95% in 0.5 period	Pass	B
	30% in 25 period	Pass	C
	>95% in 250 period	Pass	C

Standard	Description	Results
EN 61000-3-2:2006 +A1:2009 +A2:2009 IEC 61000-3-2:2005 +A1:2008 +A2:2009	Limits for harmonics current emissions	Pass
EN 61000-3-3:2013 IEC 61000-3-3:2013	Limits for voltage fluctuations and flicker in low-voltage supply systems.	Pass

<to be continued>

We, Apacer Technology Inc., hereby declare that the equipment bearing the trade name and model number specified above was tested conforming to the applicable Rules under the most accurate measurement standards possible, and that all the necessary steps have been taken and are in force to assure that production units of the same equipment will continue to comply with the requirements.

Sheng-Wei Yu
Apacer Technology Inc.

Date: December 26, 2014

ISL
Draft

CE TEST REPORT

of
EN55022 / CISPR 22 / AS/NZS CISPR 22
Class B
EN55024 / CISPR 24 / IMMUNITY
EN61000-3-2 / EN61000-3-3

Product : **HalfSlim SSD**

Model(s): **SFD18SH/-M/-MK**

Brand: **Apacer**

Applicant: **Apacer Technology Inc.**

Address: **1F., No.32, Zhongcheng Rd., Tucheng Dist.,
New Taipei City 236, Taiwan , R.O.C.**

Test Performed by:

International Standards Laboratory

<Lung-Tan LAB>

*Site Registration No.

BSMI: SL2-IN-E-0013; SL2-R1/R2-E-0013; TAF: 0997

FCC: TW1036; IC: IC4067B-1; NEMKO: ELA 113B

VCCI: <Conduction 02>C-1440, T-1676, <Conduction 03>C-2845,

T-1464, <Chamber 02>R-1435, G-17, <Chamber 12>R-2598,G-16,

<Chamber 14>G-211,

*Address:

No. 120, Lane 180, San Ho Tsuen, Hsin Ho Rd.

Lung-Tan Hsiang, Tao Yuan County 325, Taiwan

*Tel: 886-3-407-1718; Fax: 886-3-407-1738

Report No.: **ISL-14LE536CE**

Issue Date : **December 26, 2014**

This report totally contains 49 pages including this cover page and contents page.

Test results given in this report apply only to the specific sample(s) tested and are traceable to national or international standard through calibration of the equipment and evaluating measurement uncertainty herein.

This test report shall not be reproduced except in full, without the written approval of International Standards Laboratory.

Contents of Report

1.	General.....	1
1.1	Certification of Accuracy of Test Data	1
1.2	Test Standards	2
1.3	Description of EUT	4
1.4	Description of Support Equipment	5
1.5	Software for Controlling Support Unit.....	6
1.6	I/O Cable Condition of EUT and Support Units	7
2.	Power Main Port Conducted Emissions	8
2.1	Test Setup and Procedure	8
2.2	Conduction Test Data: Configuration 1	9
2.3	Test Setup Photo.....	11
3.	Telecommunication Port Conducted Emissions	13
3.1	Test Setup and Procedure	13
4.	Radiated Disturbance Emissions	14
4.1	Test Setup and Procedure	14
4.2	Radiation Test Data: Configuration 1.....	16
4.3	Test Setup Photo.....	20
5.	Electrostatic discharge (ESD) immunity	22
5.1	Test Specification	22
5.2	Test Setup	22
5.3	Test Result	22
5.4	Test Point.....	23
5.5	Test Setup Photo.....	24
6.	Radio-Frequency, Electromagnetic Field immunity.....	25
6.1	Test Specification	25
6.2	Test Setup	25
6.3	Test Result	25
6.4	Test Setup Photo.....	26
7.	Electrical Fast transients/burst immunity	27
7.1	Test Specification	27
7.2	Test Setup	28
7.3	Test Result	28
7.4	Test Setup Photo.....	29
8.	Surge Immunity	30
8.1	Test Specification	30
8.2	Test Setup	30
8.3	Test Result	30
8.4	Test Setup Photo.....	31
9.	Immunity to Conductive Disturbance.....	32
9.1	Test Specification	32
9.2	Test Setup	32
9.3	Test Result	32
9.4	Test Setup Photo.....	33

Contents of Report

10.	Power Frequency Magnetic Field immunity	34
10.1	Test Specification.....	34
10.2	Test Setup.....	34
10.3	Test Result.....	34
10.4	Test Setup Photo	35
11.	Voltage Dips, Short Interruption and Voltage Variation immunity	36
11.1	Test Specification.....	36
11.2	Test Setup.....	36
11.3	Test Result.....	36
11.4	Test Setup Photo	37
12.	Harmonics	38
12.1	Test Specification.....	38
12.2	Test Setup.....	38
12.3	Test Result.....	38
13.	Voltage Fluctuations	39
13.1	Test Specification.....	39
13.2	Test Setup.....	39
13.3	Test Result.....	39
13.4	Test Data	40
13.5	Test Setup Photo	41
14.	Appendix.....	42
14.1	Appendix A: Test Equipment.....	42
14.2	Appendix B: Uncertainty of Measurement	45
14.3	Appendix C: Photographs of EUT Please refer to the File of ISL-14LE536P	46

1. General

1.1 Certification of Accuracy of Test Data

Standards: Please refer to 1.2

Equipment Tested: HalfSlim SSD

Model: SFD18SH/-M/-MK

Brand: Apacer

Applicant: Apacer Technology Inc.

Sample received Date: December 15, 2014

Final test Date: EMI:refer to the date of test data
EMS: December 23, 2014

Test Site: International Standards Laboratory
Chamber 12; Chamber 14; Conduction 03; Immunity 02

Test Distance: 10M; 3M (above1GHz) (EMI test)

Temperature: refer to each site test data

Humidity: refer to each site test data

Input power: Conduction input power: AC 230 V / 50 Hz
Radiation input power: AC 230 V / 50 Hz
Immunity input power: AC 230 V / 50 Hz

Test Result: **PASS**

Report Engineer: Cheryl Tung

Test Engineer:

Approved By:

Lawrence Wang



Jim Chu / Director

1.2 Test Standards

The tests which this report describes were conducted by an independent electromagnetic compatibility consultant, International Standards Laboratory in accordance with the following

EN 55022:2010+AC:2011, CISPR 22:2008 (modified) and AS/NZS CISPR 22: 2009+A1:2010: Class B: Limits and methods of measurement of Radio Interference characteristics of Information Technology Equipment.

EN 55024:2010 and CISPR 24:2010: Information technology equipment-Immunity characteristics - Limits and methods of measurement.

Standard	Description	Results	Criteria
EN 61000-4-2:2009 IEC 61000-4-2:2008	Electrostatic Discharge	Pass	B
EN 61000-4-3:2006+A1:2008 +A2:2010 IEC 61000-4-3:2006+A1:2007+A2:2010	Radio-Frequency, Electromagnetic Field	Pass	A
EN 61000-4-4:2012 IEC 61000-4-4:2012	Electrical Fast Transient/Burst	Pass	B
EN 61000-4-5:2006 IEC 61000-4-5:2005	Surge	Pass	B
EN 61000-4-6:2009 IEC 61000-4-6:2008	Conductive Disturbance	Pass	A
EN 61000-4-8:2010 IEC 61000-4-8:2009	Power Frequency Magnetic Field	Pass	A
EN 61000-4-11:2004 IEC 61000-4-11:2004	Voltage Dips / Short Interruption and Voltage Variation		
	>95% in 0.5 period	Pass	B
	30% in 25 period	Pass	C
	>95% in 250 period	Pass	C

Standard	Description	Results
EN 61000-3-2:2006 +A1:2009 +A2:2009 IEC 61000-3-2:2005 +A1:2008 +A2:2009	Limits for harmonics current emissions	Pass
EN 61000-3-3:2013 IEC 61000-3-3:2013	Limits for voltage fluctuations and flicker in low-voltage supply systems.	Pass

1.2.1 Performance Criteria for Compliance: EN 55024

Performance criterion A

During and after the test the EUT shall continue to operate as intended without operator intervention. No degradation of performance or loss of function is allowed below a minimum performance level specified by the manufacturer when the EUT is used as intended. The performance level may be replaced by a permissible loss of performance. If the minimum performance level or the permissible performance loss is not specified by the manufacturer, then either of these may be derived from the product description and documentation, and by what the user may reasonably expect from the EUT if used as intended.

Performance criterion B

After the test, the EUT shall continue to operate as intended without operator intervention. No degradation of performance or loss of function is allowed, after the application of the phenomena below a performance level specified by the manufacturer, when the EUT is used as intended. The performance level may be replaced by a permissible loss of performance. During the test, degradation of performance is allowed. However, no change of operating state or stored data is allowed to persist after the test. If the minimum performance level (or the permissible performance loss) is not specified by the manufacturer, then either of these may be derived from the product description and documentation, and by what the user may reasonably expect from the EUT if used as intended.

Performance criterion C

During and after testing, a temporary loss of function is allowed, provided the function is self-recoverable, or can be restored by the operation of the controls or cycling of the power to the EUT by the user in accordance with the manufacturer's instructions.

Functions, and/or information stored in non-volatile memory, or protected by a battery backup, shall not be lost.

1.3 Description of EUT

EUT

Description: HalfSlim SSD
 Condition: Pre-Production
 Model: SFD18SH/-M/-MK
 Memory Capacity: 1GB~256GB
 Serial Number: N/A
 Control IC: SRP40CB0; SRP40EB0
 PCBA Number: FSD0DF14OCZ1-MN
 Highest working frequency: 6GHz
 The radiation test should be tested till 6GHz

The memory capacities listed below are chosen by the applicant to be the representative configuration for testing in this report.

Test configurations:

Configuration	Control IC	Memory Capacity
1	SRP40CB0	256GB

Control IC difference:

Model	Memory Capacity	Control IC	Different
SFD18SH/-M/-MK	1GB~256GB	SRP40CB0; SRP40EB0	Different Market

EMI Noise Source:

Refer to the photo	Crystal	Point
EUT-5	30MHz	Y1

EMI Solution:

N/A

1.4 Description of Support Equipment

For EMI Support unit: 1~6

For EMS Support unit: 4~9

No	Unit	Model / Serial No.	Brand	Power Cord	FCC ID
1	Personal Computer	A13 S/N: PBYXED3	Lenovo	Non-shielded	FCC DOC
2	PS/2 Mouse	M-SBM96B S/N: NA	Logitech	Non-shielded	FCC DOC
3	24" LCD Monitor	ST 2420Lb S/N: NA	DELL	Non-shielded	FCC DOC
4	HP Printer	C930 S/N: N/A	HP	Non-shielded	FCC DOC
5	Aceex Modem	DM1414 S/N: N/A	Aceex	Non-shielded	FCC DOC
6	PS/2 Keyboard	Y-S0002 S/N: N/A	Logitech	N/A	FCC DOC
7	24" LCD Monitor	U2410F S/N: N/A	DELL	Non-shielded	FCC DOC
8	USB Mouse	MOCZUL S/N: NA	DELL	Non-shielded	FCC DOC
9	Personal Computer	WLIH77G12B7 S/N: N/A	LEMEL	Non-shielded	FCC DOC

1.5 Software for Controlling Support Unit

Test programs exercising various part of EUT were used. The programs were executed as follows:

For EMI & EMS test configuration:

1. PC running EMCTEST read and write the EUT.
2. Send signal to the Printer through PC Parallel Port.
3. Send signal to the Modem through PC Serial Port.
4. Send H pattern to the 24" LCD Monitor through PC D-SUB Port.
5. Repeat the above steps.

	Filename	Issued Date
EUT	EMCTEST	04/11/2007
Printer	EMCTEST	04/11/2007
Modem	EMCTEST	04/11/2007
Monitor	EMCTEST	04/11/2007

1.6 I/O Cable Condition of EUT and Support Units

For EMI

Description	Path	Cable Length	Cable Type
AC Power Cable	110V (~240V) to PC SPS	1.8m	Non-shielded
PS/2 Keyboard Data Cable	PS/2 Keyboard to PC PS/2 Keyboard Port	1.8m	Shielded
PS/2 Mouse Data Cable	PS/2 Mouse to PC PS/2 Port	1.8m	Shielded
Printer Data Cable	Printer to PC Parallel Port	1.8m	Shielded
Modem Data Cable	Modem to PC Serial Port	1.8m	Shielded
Monitor Data Cable	Monitor D-SUB Port to PC D-SUB Port	1.8m	Shielded (with core)

For EMS

Description	Path	Cable Length	Cable Type
AC Power Cable	110V (~240V) to PC SPS	1.8m	Non-shielded
PS/2 Keyboard Data Cable	PS/2 Keyboard to PC PS/2 Keyboard Port	1.8m	Shielded
USB Mouse Data Cable	USB Mouse to PC USB 2.0 Port	1.8m	Shielded
Printer Data Cable	Printer to PC Parallel Port	1.8m	Shielded
Modem Data Cable	Modem to PC Serial Port	1.8m	Shielded
Monitor Data Cable	Monitor D-SUB Port to PC D-SUB Port	1.8m	Shielded (with core)

2. Power Main Port Conducted Emissions

2.1 Test Setup and Procedure

2.1.1 Test Setup

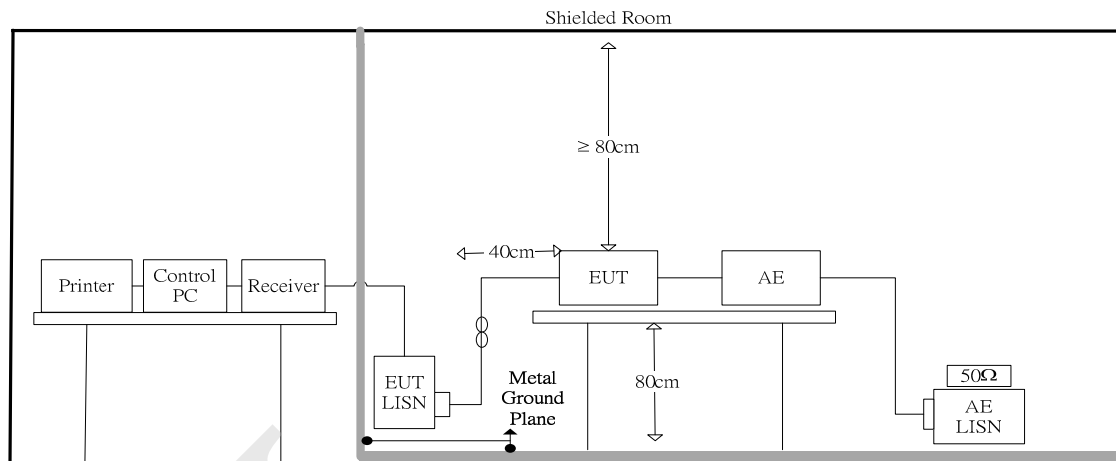

2.1.2 Test Procedure

The measurements are performed in a 3.5m x 3.4m x 2.5m shielded room, which referred as Conduction 01 test site, or a 3m x 3m x 2.3m test site, which referred as Conduction 02 test site. The EUT was placed on non-conduction 1.0m x 1.5m table, which is 0.8 meters above an earth-grounded.

Power to the EUT was provided through the LISN which has the Impedance (50ohm/50uH) vs. Frequency Characteristic in accordance with the standard. Power to the LISNs were filtered to eliminate ambient signal interference and these filters were bonded to the ground plane. Peripheral equipment required to provide a functional system (support equipment) for EUT testing was powered from the second LISN through a ganged, metal power outlet box which is bonded to the ground plane at the LISN.

The interconnecting cables were arranged and moved to get the maximum measurement. Both the line of power cord, hot and neutral, were measured. All of the interface cables were manipulated according to EN 55022 requirements.

The highest emissions were analyzed in details by operating the spectrum analyzer in fixed tuned mode to determine the nature of the emissions and to provide information which could be useful in reducing their amplitude.

2.1.3 EMI Receiver/Spectrum Analyzer Configuration (for the frequencies tested)

Frequency Range:	150KHz--30MHz
Detector Function:	Quasi-Peak / Average Mode
Resolution Bandwidth:	9KHz

2.2 Conduction Test Data: Configuration 1

Table 2.2.1 Power Line Conducted Emissions (Line)

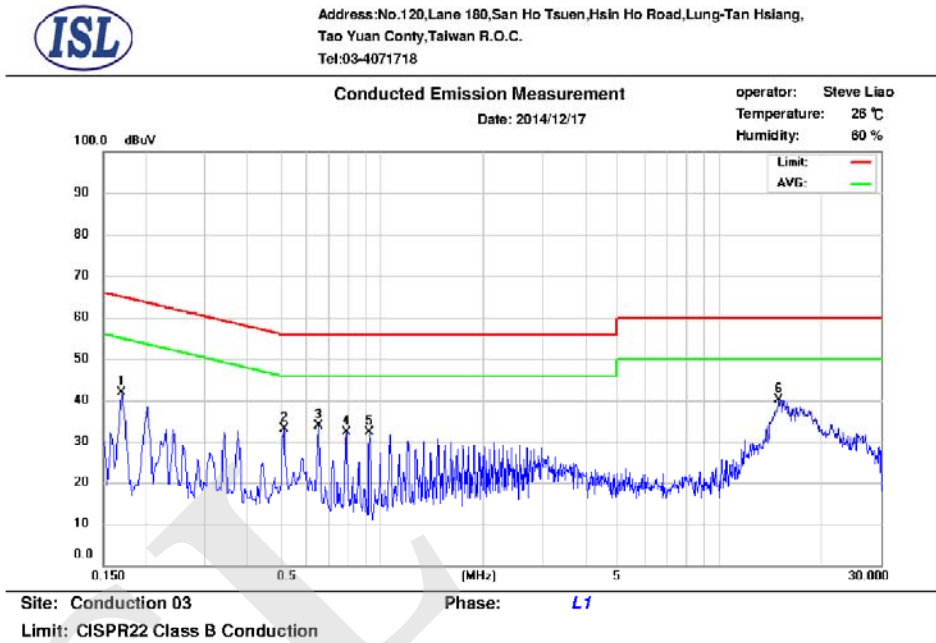

No.	Frequency (MHz)	Correct Factor (dB)	QP Emission (dBuV)	QP Limit (dBuV)	QP Margin (dB)	AVG Emission (dBuV)	AVG Limit (dBuV)	AVG Margin (dB)	Note
1	0.170	9.65	41.12	64.96	-23.84	35.70	54.96	-19.26	
2	0.514	9.68	31.09	56.00	-24.91	29.92	46.00	-16.08	
3	0.650	9.68	31.91	56.00	-24.09	31.33	46.00	-14.67	
4	0.786	9.70	31.98	56.00	-24.02	31.58	46.00	-14.42	
5	0.922	9.70	31.93	56.00	-24.07	31.37	46.00	-14.63	
6	15.022	10.00	33.43	60.00	-26.57	23.07	50.00	-26.93	

Note:

Margin = QP/AVG Emission - Limit

QP/AVG Emission = Receiver Reading + Correct Factor

Correct Factor = LISN Loss + Cable Loss

A margin of -8dB means that the emission is 8dB below the limit

The frequency spectrum graph is for final peak graph, and the attached table is for QP/AVG test result.

If peak data can pass, it will be shown in "QP/AVG Correct" column, if not, QP/AVG data will instead.

Table 2.2.2 Power Line Conducted Emissions (Neutral)

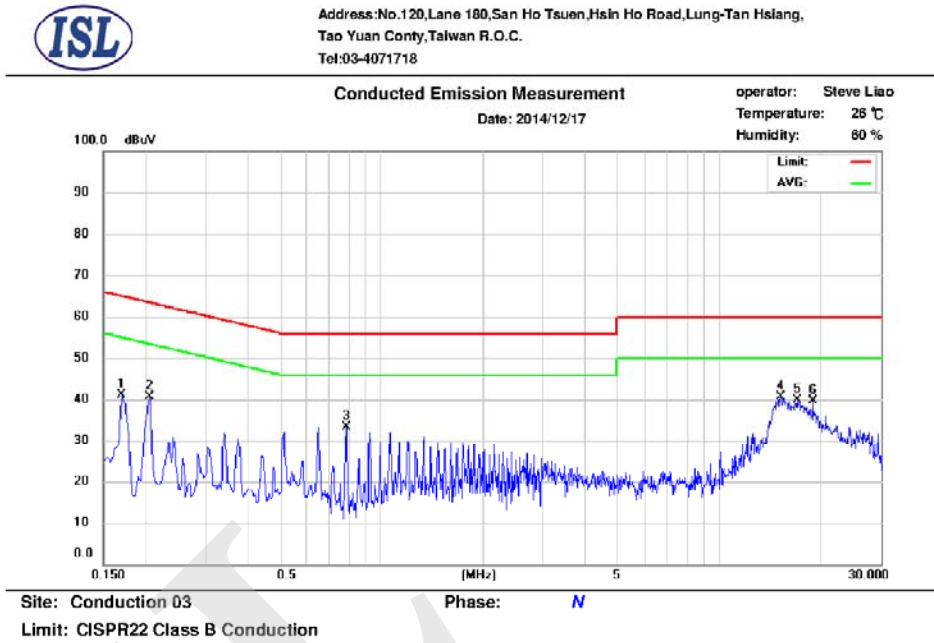

No.	Frequency (MHz)	Correct Factor (dB)	QP Emission (dBuV)	QP Limit (dBuV)	QP Margin (dB)	AVG Emission (dBuV)	AVG Limit (dBuV)	AVG Margin (dB)	Note
1	0.170	9.65	40.48	64.96	-24.48	32.91	54.96	-22.05	
2	0.206	9.65	41.04	63.37	-22.33	27.14	53.37	-26.23	
3	0.786	9.70	31.99	56.00	-24.01	31.71	46.00	-14.29	
4	15.226	10.02	34.20	60.00	-25.80	24.26	50.00	-25.74	
5	16.954	10.04	32.62	60.00	-27.38	26.00	50.00	-24.00	
6	18.890	10.06	32.32	60.00	-27.68	26.69	50.00	-23.31	

Note:

Margin = QP/AVG Emission - Limit

QP/AVG Emission = Receiver Reading + Correct Factor

Correct Factor = LISN Loss + Cable Loss

A margin of -8dB means that the emission is 8dB below the limit

The frequency spectrum graph is for final peak graph, and the attached table is for QP/AVG test result.

If peak data can pass, it will be shown in "QP/AVG Correct" column, if not, QP/AVG data will instead.

2.3 Test Setup Photo

Front View



Back View

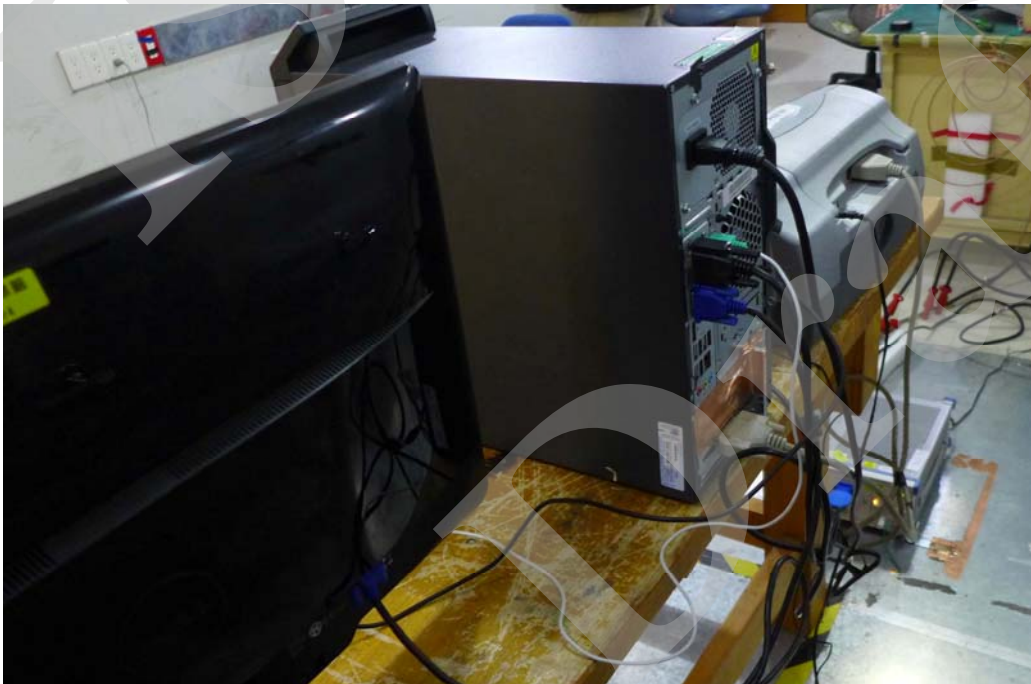

4. Radiated Disturbance Emissions

4.1 Test Setup and Procedure

4.1.1 Test Setup

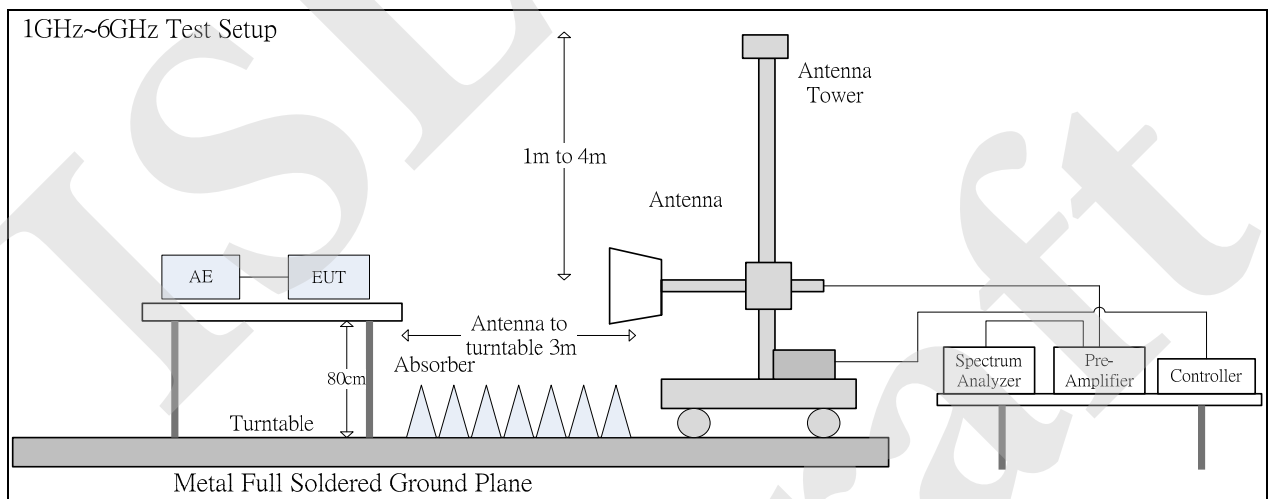
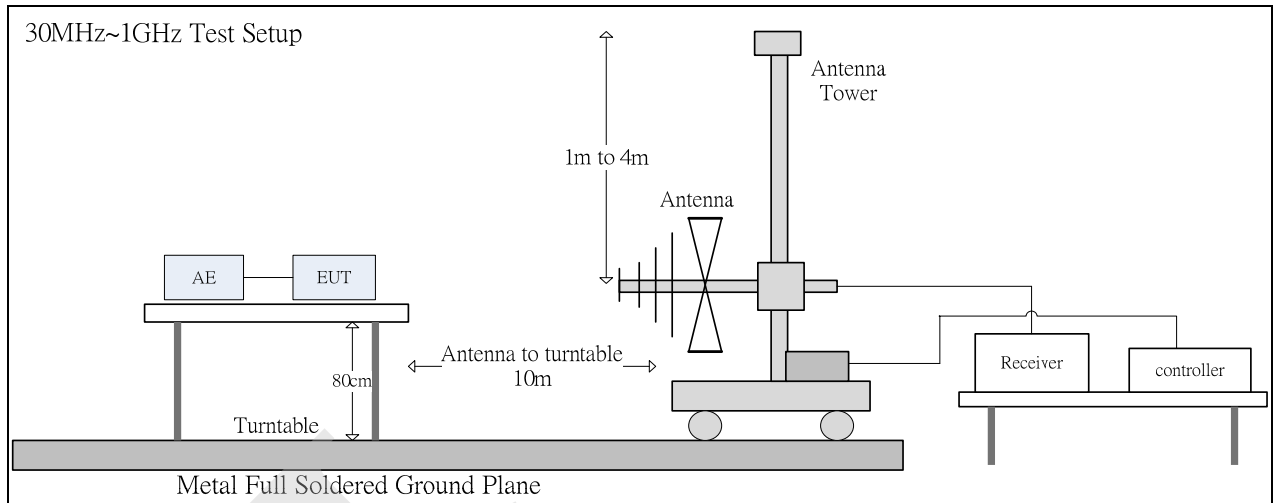

4.1.2 Test Procedure

The radiated emissions test will then be repeated on the open site or chamber to measure the amplitudes accurately and without the multiple reflections existing in the shielded room. The EUT and support equipment are set up on the turntable of one of 10 meter open field sites or 10 meter chamber. Desktop EUT are set up on a wooden stand 0.8 meter above the ground or floor-standing arrangement shall be placed on the horizontal ground reference plane. The test volume for a height of up to 30 cm may be obstructed by absorber placed on the ground plane.

For the initial measurements, the receiving antenna is varied from 1-4 meter height and is changed in the vertical plane from vertical to horizontal polarization at each frequency. The highest emissions between 30 MHz to 1000 MHz were analyzed in details by operating the spectrum analyzer and/or EMI receiver in quasi-peak mode to determine the precise amplitude of the emissions. The highest emissions between 1 GHz to 6 GHz were analyzed in details by operating the spectrum analyzer in peak and average mode to determine the precise amplitude of the emissions.

At the highest amplitudes observed, the EUT is rotated in the horizontal plane while changing the antenna polarization in the vertical plane to maximize the reading. The interconnecting cables were arranged and moved to get the maximum measurement. Once the maximum reading is obtained, the antenna elevation and polarization will be varied between specified limits to maximize the readings. All of the interface cables were manipulated according to EN 55022 requirements.

The highest internal source of an EUT is defined as the highest frequency generated or used within the EUT or on which the EUT operates or tunes. If the highest frequency of the internal sources of the EUT is less than 108 MHz, the measurement shall only be made up to 1 GHz. If the highest frequency of the internal sources of the EUT is between 108 MHz and 500 MHz, the measurement shall only be made up to 2 GHz. If the highest frequency of the internal sources of the EUT is between 500 MHz and 1 GHz, the measurement shall only be made up to 5 GHz. If the highest frequency of the internal sources of the EUT is above 1 GHz, the measurement shall be made up to 5 times the highest frequency or 6 GHz, whichever is less.

4.1.3 Spectrum Analyzer Configuration (for the frequencies tested)

Frequency Range:	30MHz--1000MHz
Detector Function:	Quasi-Peak Mode
Resolution Bandwidth:	120KHz
Frequency Range:	Above 1 GHz to 6 GHz
Detector Function:	Peak/Average Mode
Resolution Bandwidth:	1MHz

4.2 Radiation Test Data: Configuration 1

Table 4.2.1 Radiated Emissions (Horizontal)

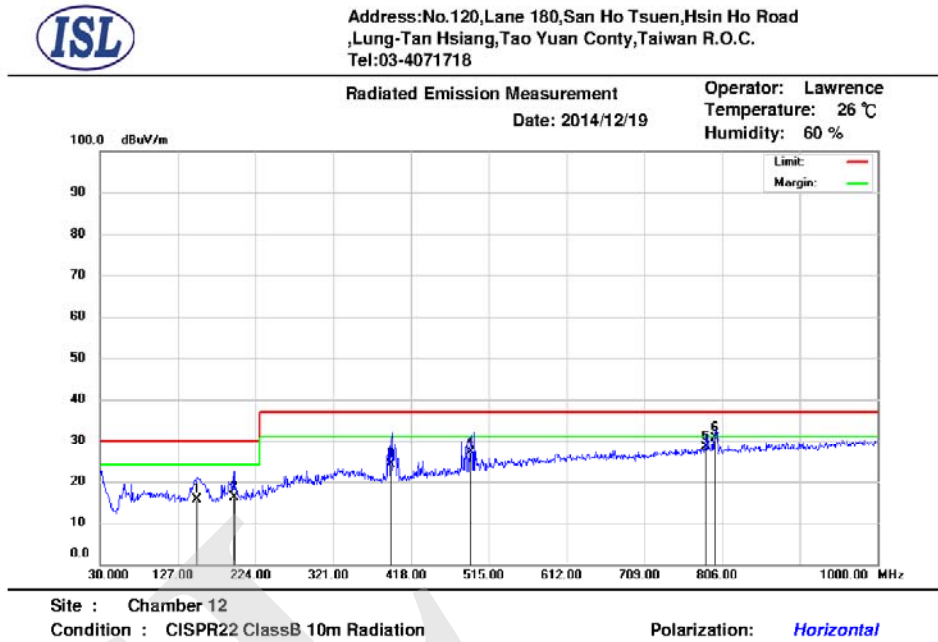

Mk.	Frequency (MHz)	RX_R (dBuV)	Correct Factor (dB/m)	Emission (dBuV/m)	Limit (dBuV/m)	Margin (dB)	Ant.Pos (cm)	Tab.Pos (deg.)	Detector
1	151.81	3.33	12.25	15.58	30.00	-14.42	267	337	QP
2	197.28	4.63	11.50	16.13	30.00	-13.87	399	287	QP
3	392.76	5.05	19.12	24.17	37.00	-12.83	399	112	QP
4	491.17	5.79	21.30	27.09	37.00	-9.91	187	237	QP
5	786.14	3.28	25.05	28.33	37.00	-8.67	100	58	QP
6	796.61	5.56	25.12	30.68	37.00	-6.32	100	149	QP

* Note:

Margin = Emission – Limit

Emission = Radiated Amplitude + Correct Factor

Correct Factor = Antenna Correction Factor + Cable Loss

A margin of -8dB means that the emission is 8dB below the limit

BILOG Antenna Distance: 10 meters

Below 1GHz test, if the peak measured value meets the QP limit, it is unnecessary to perform the QP measurement.



Address: No.120, Lane 180, San Ho Tsuen, Hsin Ho Road
, Lung-Tan Hsiang, Tao Yuan Conty, Taiwan R.O.C.
Tel: 03-4071718

Radiated Emission Measurement
Date: 2014/12/20

Operator: Jerry
Temperature: 26 °C
Humidity: 60 %

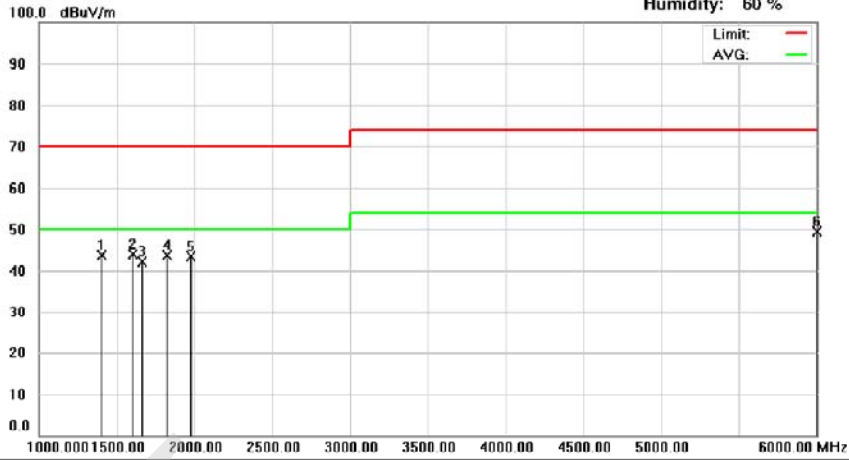

Site : Chamber 14

Condition : CISPR22 ClassB Radiation(Peak)

Polarization: *Horizontal*

Mk.	Frequency (MHz)	RX_R (dBuV)	Correct Factor(dB/m)	Emission (dBuV/m)	Limit (dBuV/m)	Margin (dB)	Ant.Pos (cm)	Tab.Pos (deg.)	Detector
1	1400.00	59.43	-15.91	43.52	70.00	-26.48	360	63	peak
2	1600.00	58.90	-14.99	43.91	70.00	-26.09	100	355	peak
3	1665.00	56.70	-14.47	42.23	70.00	-27.77	387	224	peak
4	1820.00	56.78	-13.21	43.57	70.00	-26.43	100	141	peak
5	1975.00	55.34	-11.96	43.38	70.00	-26.62	100	347	peak
6	6000.00	56.63	-7.31	49.32	74.00	-24.68	100	41	peak

* Note:

Margin = Emission – Limit

Emission = Radiated Amplitude + Correct Factor

Correct Factor = Antenna Correction Factor + Cable Loss – Pre-Amplifier Gain

A margin of -8dB means that the emission is 8dB below the limit

Horn Antenna Distance: 3 meters

Above 1GHz test, if the peak measured value meets the average limit, it is unnecessary to perform the average measurement.

Table 4.2.2 Radiated Emissions (Vertical)



Address: No.120, Lane 180, San Ho Tsuen, Hsin Ho Road
, Lung-Tan Hsiang, Tao Yuan Conty, Taiwan R.O.C.
Tel: 03-4071718

Radiated Emission Measurement Operator: Lawrence
Date: 2014/12/19 Temperature: 26 °C
Humidity: 60 %

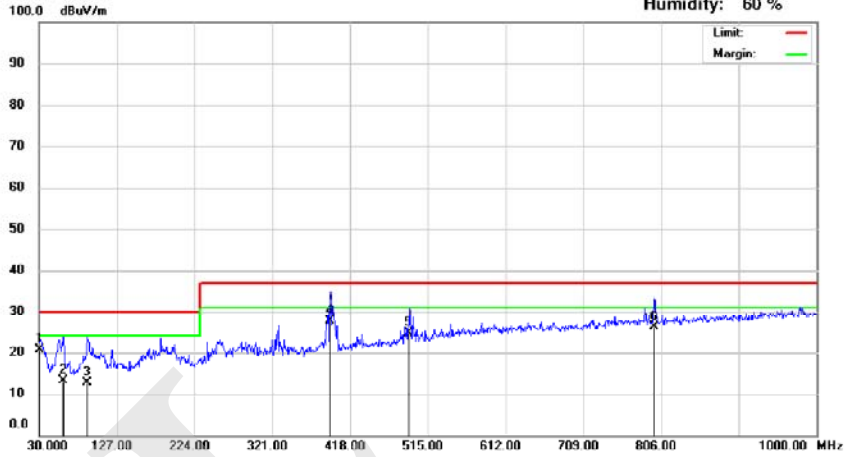

Site : Chamber 12 Polarization: *Vertical*
Condition : CISPR22 ClassB 10m Radiation

Mk.	Frequency (MHz)	RX_R (dBuV)	Correct Factor(dB/m)	Emission (dBuV/m)	Limit (dBuV/m)	Margin (dB)	Ant.Pos (cm)	Tab.Pos (deg.)	Detector
1	30.14	0.85	19.68	20.53	30.00	-9.47	100	0	QP
2	60.52	5.23	7.88	13.11	30.00	-16.89	100	170	QP
3	90.23	2.07	10.60	12.67	30.00	-17.33	100	349	QP
4	393.00	8.54	19.12	27.66	37.00	-9.34	310	189	QP
5	491.21	3.25	21.30	24.55	37.00	-12.45	161	0	QP
6	796.70	1.00	25.12	26.12	37.00	-10.88	223	194	QP

* Note:
Margin = Emission – Limit
Emission = Radiated Amplitude + Correct Factor
Correct Factor = Antenna Correction Factor + Cable Loss
A margin of -8dB means that the emission is 8dB below the limit
BILOG Antenna Distance: 10 meters

Below 1GHz test, if the peak measured value meets the QP limit, it is unnecessary to perform the QP measurement.



Address: No.120, Lane 180, San Ho Tsuen, Hsin Ho Road
, Lung-Tan Hsiang, Tao Yuan Conty, Taiwan R.O.C.
Tel: 03-4071718

Radiated Emission Measurement

Date: 2014/12/20

Operator: Jerry

Temperature: 26 °C

Humidity: 60 %

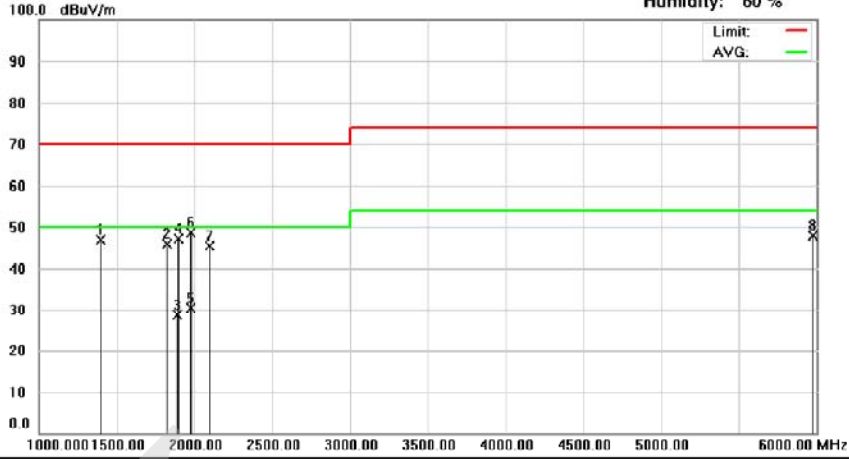

Site : Chamber 14

Condition : CISPR22 ClassB Radiation(Peak)

Polarization: Vertical

Mk.	Frequency (MHz)	RX_R (dBuV)	Correct Factor(dB/m)	Emission (dBuV/m)	Limit (dBuV/m)	Margin (dB)	Ant.Pos (cm)	Tab.Pos (deg.)	Detector
1	1395.00	62.89	-15.92	46.97	70.00	-23.03	343	298	peak
2	1820.00	58.99	-13.21	45.78	70.00	-24.22	100	144	peak
3	1869.84	41.31	-12.66	28.65	50.00	-21.35	101	329	AVG
4	1895.00	59.84	-12.62	47.22	70.00	-22.78	100	12	peak
5	1971.45	42.32	-12.00	30.32	50.00	-19.68	106	325	AVG
6	1975.00	60.64	-11.96	48.68	70.00	-21.32	100	24	peak
7	2095.00	56.98	-11.64	45.34	70.00	-24.66	114	240	peak
8	5975.00	55.16	-7.35	47.81	74.00	-26.19	313	34	peak

* Note:

Margin = Emission – Limit

Emission = Radiated Amplitude + Correct Factor

Correct Factor = Antenna Correction Factor + Cable Loss – Pre-Amplifier Gain

A margin of -8dB means that the emission is 8dB below the limit

Horn Antenna Distance: 3 meters

Above 1GHz test, if the peak measured value meets the average limit, it is unnecessary to perform the average measurement.

4.3 Test Setup Photo

Front View (30MHz~1GHz)



Back View (30MHz~1GHz)

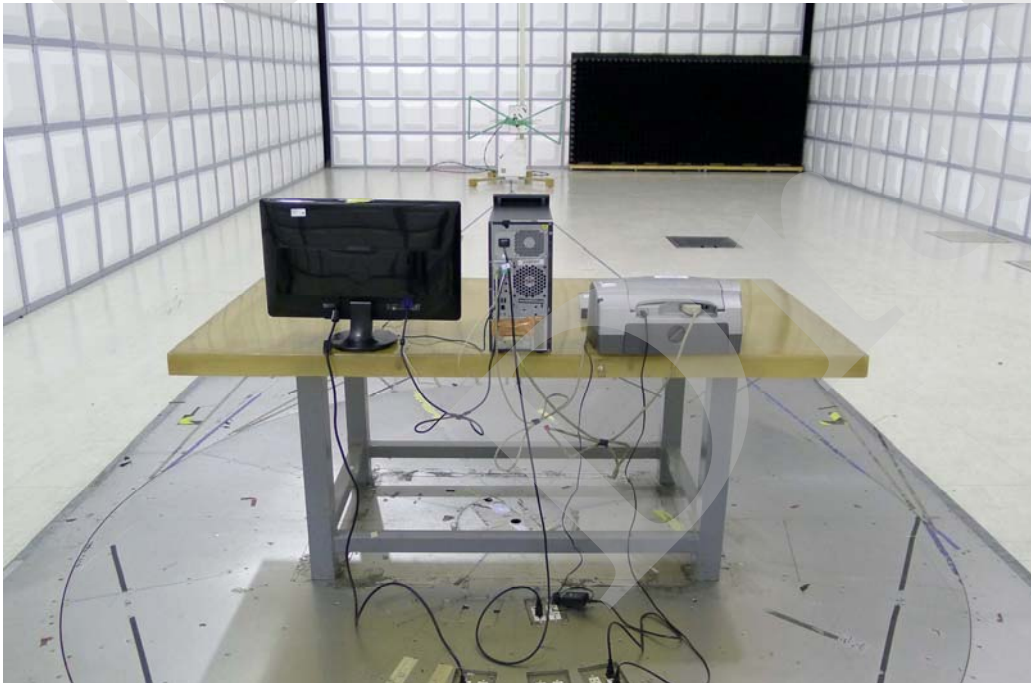

Front View (above 1GHz)



Back View (above 1GHz)

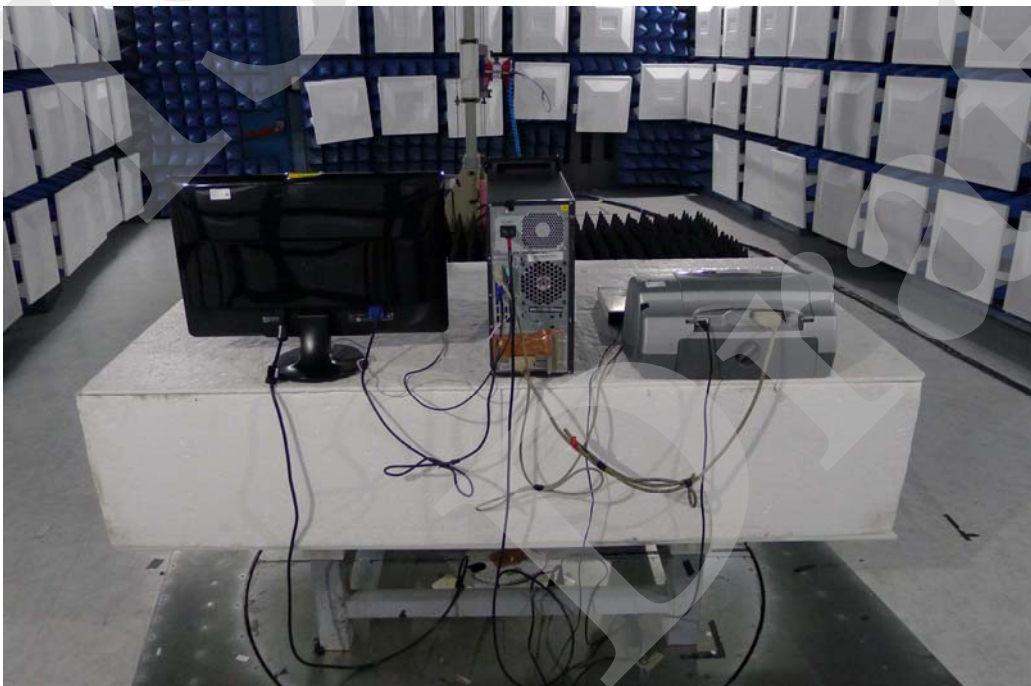

5. Electrostatic discharge (ESD) immunity

5.1 Test Specification

Port:	Enclosure
Basic Standard:	EN 61000-4-2/ IEC EN61000-4-2 (details referred to Sec 1.2)
Test Level:	Air +/- 2 kV, +/- 4 kV, +/- 8 kV Contact +/- 4 kV
Criteria:	B
Test Procedure	refer to ISL QA -T4-E-S7
Temperature:	23 °C
Humidity:	40%

Selected Test Point

Air: discharges were applied to slots, aperture or insulating surfaces. 10 single air discharges were applied to each selected points.

Contact: Total 200 discharges minimum were to the selected contact points.

Indirect Contact Points: 25 discharges were applied to center of one edge of VCP and each EUT side of HCP with 10 cm away from EUT.

5.2 Test Setup

EUT is 1m from the wall and other metallic structure. When Battery test mode is needed, a cable with one 470KΩ resistor at two rare ends is connected from metallic part of EUT and screwed to HCP.

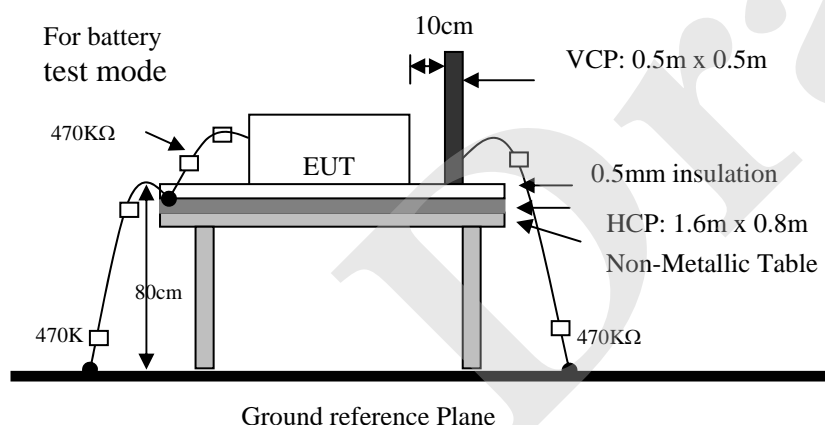

5.3 Test Result

Performance of EUT complies with the given specification.

5.4 Test Point

Red arrow lines indicate the contact points, and blue arrow lines indicate the air points.

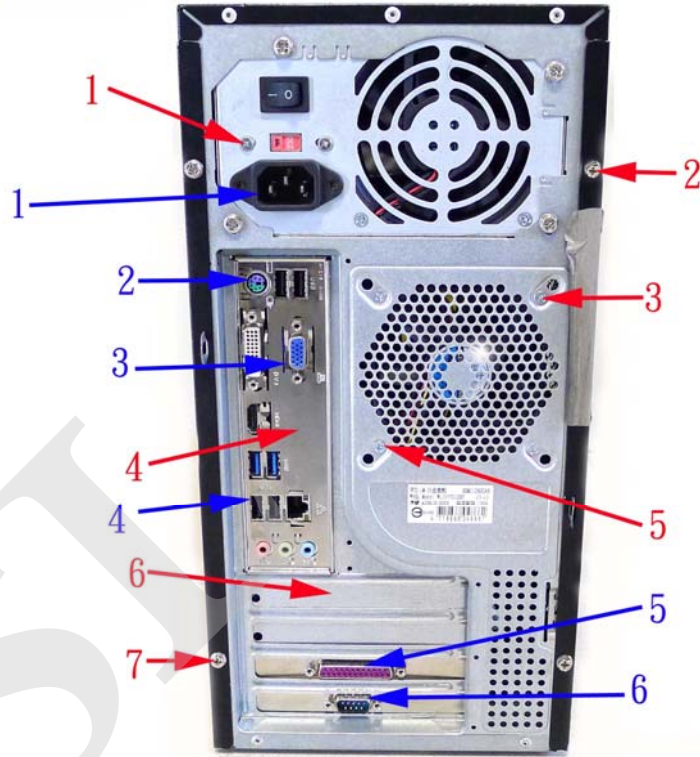

5.5 Test Setup Photo



ISL
Draft

6. Radio-Frequency, Electromagnetic Field immunity

6.1 Test Specification

Port:	Enclosure
Basic Standard:	EN 61000-4-3/ IEC EN61000-4-3 (details referred to Sec 1.2)
Test Level:	3 V/m
Modulation:	AM 1KHz 80%
Frequency range:	80 MHz~1 GHz
Frequency Step:	1% of last step frequency
Dwell time:	3s
Polarization:	Vertical and Horizontal
EUT Azimuth Angle	☒0° ☒90° ☒180° ☒270°
Criteria:	A
Test Procedure	refer to ISL QA -T4-E-S8
Temperature:	23°C
Humidity:	42%

6.2 Test Setup

The field sensor is placed at one calibration grid point to check the intensity of the established fields on both polarizations. EUT is adjusted to have each side of EUT face coincident with the calibration plane. A CCD camera and speakers are used to monitor the condition of EUT for the performance judgment.

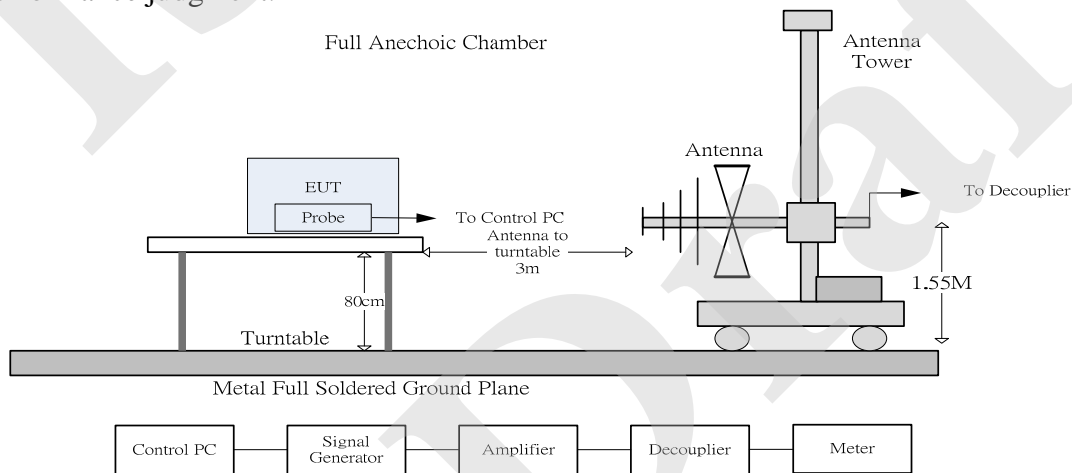

6.3 Test Result

Performance of EUT complies with the given specification.

6.4 Test Setup Photo



7. Electrical Fast transients/burst immunity

7.1 Test Specification

Port:	AC mains
Basic Standard:	EN 61000-4-4/ IEC EN61000-4-4 (details referred to Sec 1.2)
Test Level:	AC Power Port: +/- 1 kV
Rise Time:	5ns
Hold Time:	50ns
Repetition Frequency:	5KHz
Criteria:	B
Test Procedure	refer to ISL QA -T4-E-S9
Temperature:	22 °C
Humidity:	44%

Test Procedure

The EUT was setup on a nonconductive table 0.1 m above a reference ground plane.

Test Points	Polarity	Result	Comment
Line	+	N	60 sec
	-	N	60 sec
Neutral	+	N	60 sec
	-	N	60 sec
Ground	+	N	60 sec
	-	N	60 sec
Line to Neutral	+	N	60 sec
	-	N	60 sec
Line to Ground	+	N	60 sec
	-	N	60 sec
Neutral to Ground	+	N	60 sec
	-	N	60 sec
Line to Neutral to Ground	+	N	60 sec
	-	N	60 sec

Note: 'N' means normal, the EUT function is correct during the test.

7.2 Test Setup

EUT is at least 50cm from the conductive structure.

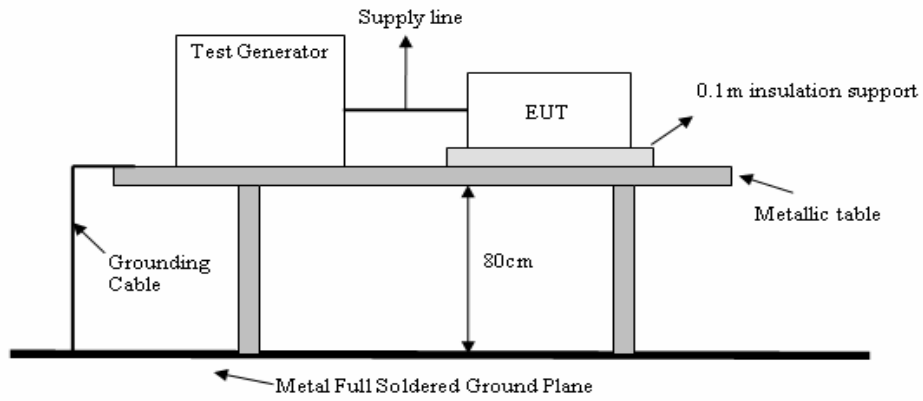

7.3 Test Result

Performance of EUT complies with the given specification.

7.4 Test Setup Photo



ISL
Draft

8. Surge Immunity

8.1 Test Specification

Port:	AC mains
Basic Standard:	EN 61000-4-5/ IEC EN61000-4-5 (details referred to Sec 1.2)
Test Level:	Line to Line: +/- 0.5 kV, +/- 1 kV Line to Earth: +/- 0.5 kV, +/- 1 kV, +/- 2kV
Rise Time:	1.2us
Hold Time:	50us
Repetition Rate:	30 seconds
Angle:	☒0° ☒90° ☒180° ☒270°
Criteria:	B
Test Procedure:	refer to ISL QA -T4-E-S10
Temperature:	22°C
Humidity:	43%

8.2 Test Setup

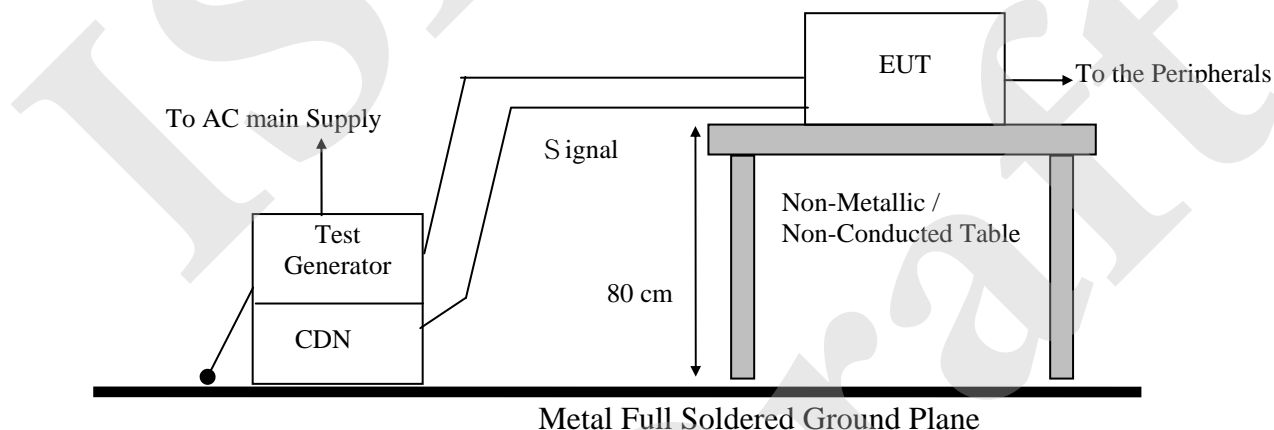

8.3 Test Result

Performance of EUT complies with the given specification.

8.4 Test Setup Photo



ISL
Draft

9. Immunity to Conductive Disturbance

9.1 Test Specification

Port:	AC mains
Basic Standard:	EN 61000-4-6/ IEC EN61000-4-6 (details referred to Sec 1.2)
Test Level:	3 V
Modulation:	AM 1KHz 80%
Frequency range:	0.15 MHz - 80MHz
Frequency Step:	1% of last Frequency
Dwell time:	3s
Criteria:	A
CDN Type:	CDN M2+M3
Test Procedure	refer to ISL QA -T4-E-S11
Temperature:	22°C
Humidity:	58%

9.2 Test Setup

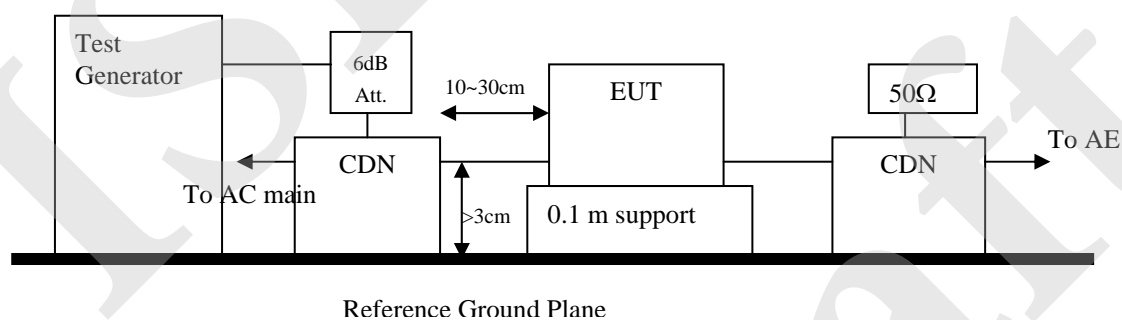

9.3 Test Result

Performance of EUT complies with the given specification.

9.4 Test Setup Photo



ISL
Draft

10. Power Frequency Magnetic Field immunity

10.1 Test Specification

Port:	Enclosure
Basic Standard:	EN 61000-4-8/ IEC EN61000-4-8 (details referred to Sec 1.2)
Test Level:	1A/m
Polarization:	X, Y, Z
Criteria:	A
Test Procedure	refer to ISL QA -T4-E-S12
Temperature:	26°C
Humidity:	45%

10.2 Test Setup

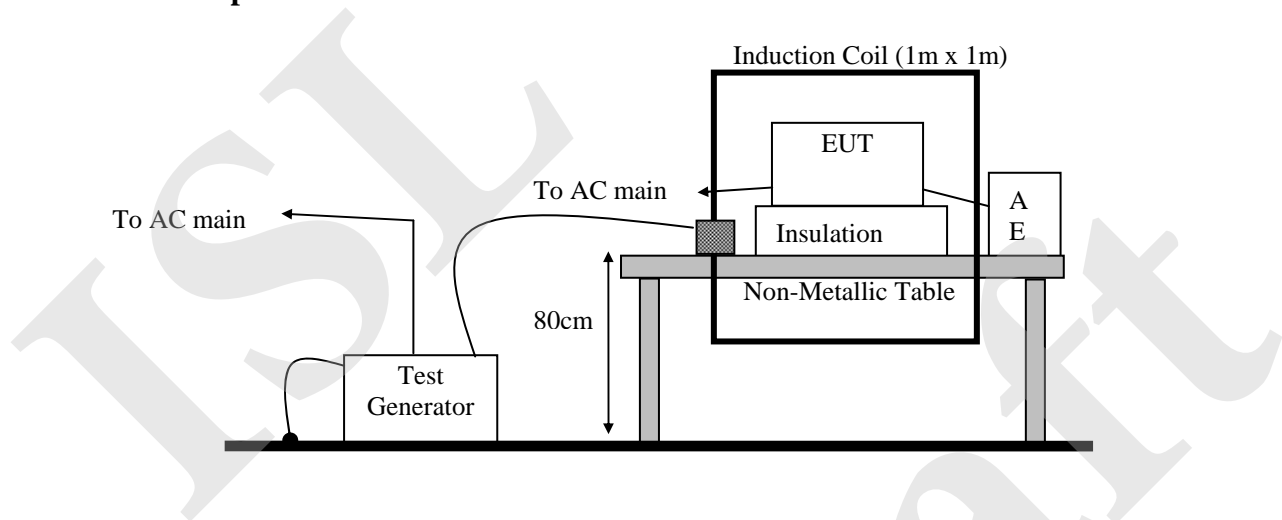

10.3 Test Result

Performance of EUT complies with the given specification.

10.4 Test Setup Photo



11. Voltage Dips, Short Interruption and Voltage Variation immunity

11.1 Test Specification

Port:	AC mains
Basic Standard:	EN 61000-4-11/ IEC EN61000-4-11 (details referred to Sec 1.2)
Test Level: Criteria:	>95% in 0.5 period B
Test Level: Criteria:	30% in 25 period C
Test Level: Criteria:	>95% in 250 period C
Phase:	0°; 180°
Test intervals:	3 times with 10s each
Test Procedure	refer to ISL QA -T4-E-S13
Temperature:	22°C
Humidity:	56%

11.2 Test Setup

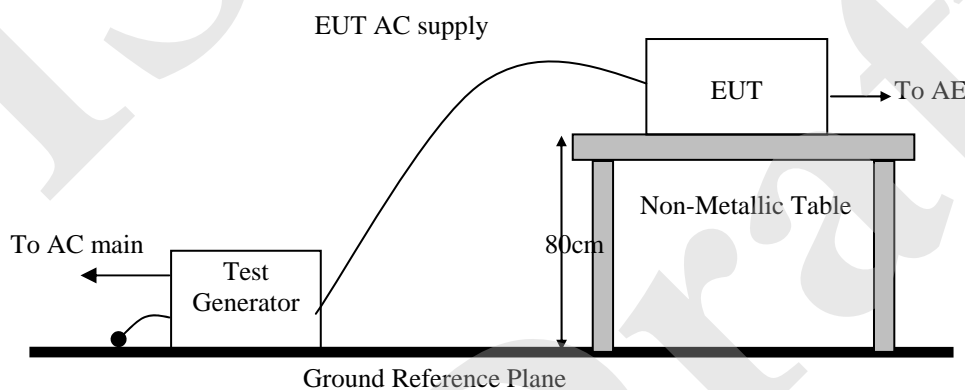

11.3 Test Result

Performance of EUT complies with the given specification.

11.4 Test Setup Photo



12. Harmonics

12.1 Test Specification

Port:	AC mains
Active Input Power:	<75W
Basic Standard:	EN61000-3-2/IEC 61000-3-2 (details referred to Sec 1.2)
Test Duration:	2.5min
Class:	D
Test Procedure	refer to ISL QA -T4-E-S14
Temperature:	24°C
Humidity:	44%

Test Procedure

The EUT is supplied in series with shunts or current transformers from a source having the same nominal voltage and frequency as the rated supply voltage and frequency of the EUT. The EUT is configured to its rated current with additional resistive load when the testing is performed.

Equipment having more than one rated voltage shall be tested at the rated voltage producing the highest harmonics as compared with the limits.

12.2 Test Setup

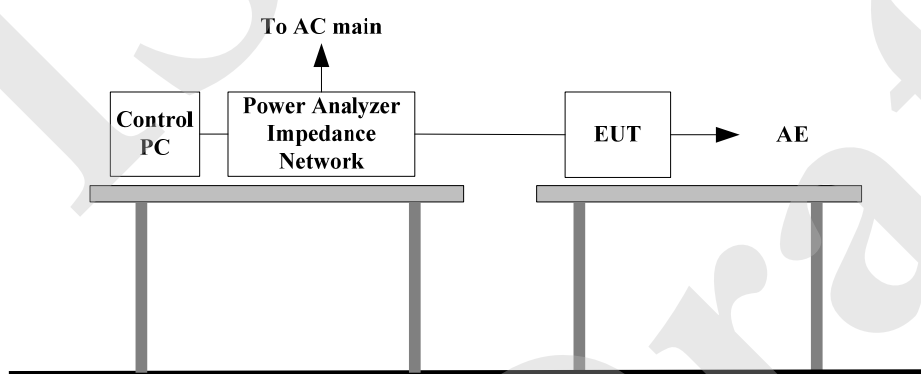

12.3 Test Result

Active input power under 75W, no limit apply, declare compliance

13. Voltage Fluctuations

13.1 Test Specification

Port:	AC mains
Basic Standard:	EN61000-3-3/IEC61000-3-3 (details referred to Sec 1.2)
Test Procedure	refer to ISL QA -T4-E-S14
Observation period:	For Pst 10min
	For Plt 2 hours
Temperature:	24°C
Humidity:	44%

Test Procedure

The EUT is supplied in series with reference impedance from a power source with the voltage and frequency as the nominal supply voltage and frequency of the EUT.

13.2 Test Setup

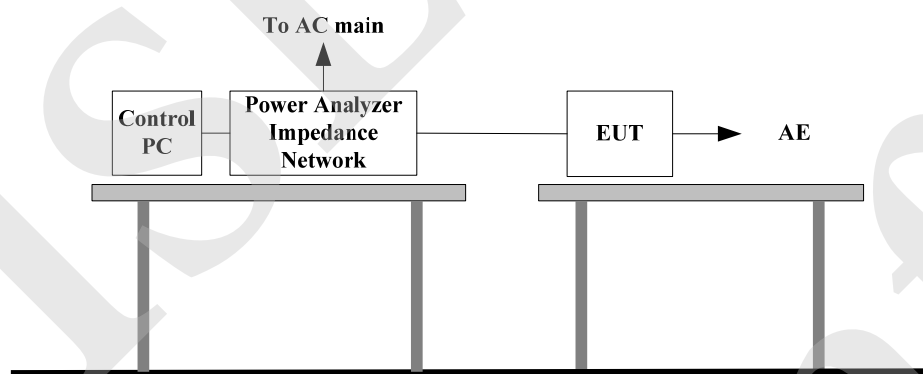

13.3 Test Result

Performance of EUT complies with the given specification.

13.4 Test Data

Flickermeter 1000-4-15 for 230V/50Hz

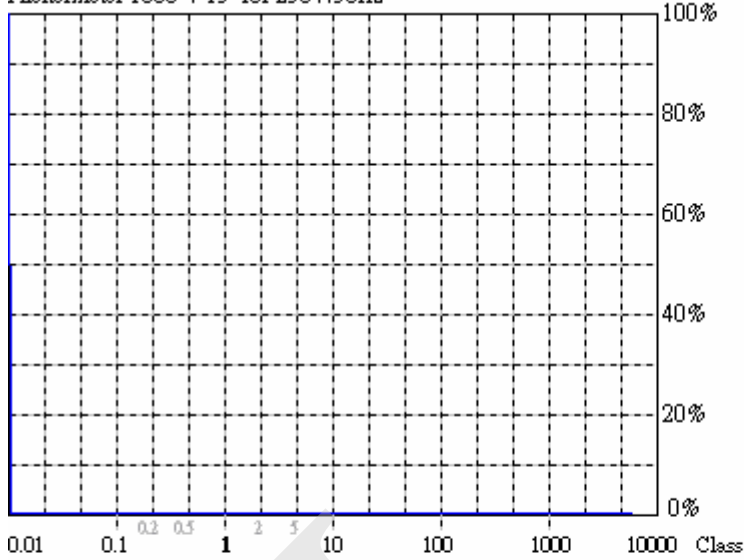

Actual Flicker (Fli):	0.00
Short-term Flicker (Pst):	0.07
Limit (Pst):	1.00
Long-term Flicker (Plt):	0.07
Limit (Plt):	0.65
Maximum Relative Volt. Change (dmax):	0.00%
Limit (dmax):	4.00%
Relative Steady-state Voltage Change (dc):	0.09%
Limit (dc):	3.30%
Maximum Interval exceeding 3.30% (dt):	0.00ms
Limit (dt>Lim):	500ms

Flicker Emission - IEC 61000-3-3 , EN 61000-3-3

U _{rms} =	230.3	V	P =	37.92	W
I _{rms} =	0.354	A	pf =	0.465	

Range:	5 A
V _{nom} :	230 V
TestTime:	120 min (10000%)

Test completed, Result: PASSED

BAR-1000 EMC-Flicker

13.5 Test Setup Photo



14. Appendix

14.1 Appendix A: Test Equipment

14.1.1 Test Equipment List

Location Con03	Equipment Name	Brand	Model	S/N	Last Cal. Date	Next Cal. Date
Conduction 03	EMI Receiver 11	ROHDE & SCHWARZ	ESCI	100568	07/19/2014	07/19/2015
Conduction 03	LISN 20	R&S	ENV216	101477	06/06/2014	06/06/2015
Conduction 03	LISN 08	ROHDE&SCHW ARZ	FCC-LISN-50/ 250-25/2/01	07039	03/11/2014	03/11/2015
Conduction 03	Conduction 03 -1 Cable	WOKEN	CFD 300-NL	Conduction 03 -1	07/11/2014	07/11/2015

Location Chmb12	Equipment Name	Brand	Model	S/N	Last Cal. Date	Next Cal. Date
Radiation (Chamber12)	BILOG Antenna 04	Schaffner	CBL6112B	2764	02/18/2014	02/18/2015
Radiation (Chamber12)	Coaxial Cable Chmb 12-10M-01	PEWC	CFD400-NL	Chmb 12-10M-01	07/11/2014	07/11/2015
Radiation (Chamber12)	EMI Receiver 10	ROHDE & SCHWARZ	ESCI	100567	07/25/2014	07/25/2015

Location Chmb14	Equipment Name	Brand	Model	S/N	Last Cal. Date	Next Cal. Date
Rad. Above 1GHz	Spectrum Analyzer 24 (1G~26.5GHz)	Agilent	N9010A	MY49060537	07/29/2014	07/29/2015
Rad. Above 1GHz	Horn Antenna 06 (1G~18G)	ETS	3117	00066665	11/27/2014	11/27/2015
Rad. Above 1GHz	Preamplifier 13	MITEQ	JS44-00101800 -25-10P-44	1329256	07/30/2014	07/30/2015
Rad. Above 1GHz	Microwave Cable 22 (1G~18G)	HUBER SUHNER	SUCOFLEX 106	501360/6 and 501361/6	02/17/2014	02/17/2015

Location	Equipment Name	Brand	Model	S/N	Last Cal. Date	Next Cal. Date
EN61K-3-2/3	Harmonic/Flicker Test System 02	EMC PARTNER	HARMONIC S-1000	143	04/11/2014	04/11/2015
EN61K-4-2	ESD Gun 05	EM TEST	Dito	V0640101838	05/26/2014	05/26/2015
EN61K-4-3	Broadband Log-Periodic Antenna	AR	AT1080	310698	N/A	N/A
EN61K-4-3	Horn Antenna RF-01	AR	ATS700M11 G	0335864	N/A	N/A
EN61K-4-3	Amplifier 80Mz~1GHz 250W	AR	250W1000A	312494	N/A	N/A
EN61K-4-3	Amplifier 800MHz~4.2GHz 50W	AR	50S1G4M1	312762	N/A	N/A
EN61K-4-3	Amplifier 4.0~8.0GHz 35W	AR	35S4G8AM1	0335752	N/A	N/A
EN61K-4-3	Broadband Coupler 80M~1GHz	Amplifier Research	DC6180A	0341805	N/A	N/A
EN61K-4-3	Coaxial Cable	INSULATED	NPS-4806-23 60-NP3	108599.003.01.03	N/A	N/A
EN61K-4-3	Broadband Coupler 0.8G~4.26GHz	AR	DC7144A	0335226	N/A	N/A
EN61K-4-3	Broadband Coupler 4G~8GHz	AR	DC7350A	0335817	N/A	N/A
EN61K-4-3	Signal Generator 07	ROHDE& SCHWARZ	SMB100A	107780	09/30/2014	09/30/2015
EN61K-4-4	EFT and SURGE Test System	EM TEST	UCS-500 M6B	V0728102674	11/26/2013	11/26/2014
EN61K-4-4	Capacitive Coupling Clamp	EM TEST	HFK	0907-106	01/10/2014	01/10/2015
EN61K-4-5	CDN-UTP8	EMC-PARTNER	CDN-UTP8	017	02/14/2014	02/14/2015
EN61K-4-5	SURGE-TESTER	EMC Partner	MIG0603IN3	523	02/14/2014	02/14/2015
EN61K-4-6	CDN M2+M3 04	Frankonia	CDN M2+M3	A2210235/2013	08/26/2014	08/26/2015
EN61K-4-6	CDN T2 03	FCC Inc.	FCC-801-T2	02066	09/02/2014	09/02/2015
EN61K-4-6	CDN T4 06	FCC Inc.	FCC-801-T4	02017	01/29/2014	01/29/2015
EN61K-4-6	CDN T8 02	FCC Inc.	FCC-801-T8	08019	08/26/2014	08/26/2015
EN61K-4-6	Coaxial Cable 4-6 02-1			4-6 02-1	N/A	N/A
EN61K-4-6	Conducted Immunity Test System 03	Frankonia	CIT-10/75	126B1151	11/10/2014	11/10/2015
EN61K-4-6	EM-Clamp	Schaffner	KEMZ-801	19215	N/A	N/A
EN61K-4-8	Magnetic Field Immunity Loop	FCC	F-1000-4-8-L-1M	01037	06/18/2014	06/18/2015
EN61K-4-8	Magnetic Field Test Generator	FCC	F-1000-4-8-G-125A	01038	06/18/2014	06/18/2015
EN61K-4-11	Voltage Dip and UP Simulator	NoiseKen	VDS-2002	VDS0640162	10/07/2014	10/07/2015

PS: N/A => The equipment does not need calibration.

14.1.2 Software for Controlling Spectrum/Receiver and Calculating Test Data

Test Item	Filename	Version
EN61000-3-2	EMC Partner	4.2
EN61000-3-3	EMC Partner	4.2
EN61000-4-2	N/A	2.0
EN61000-4-3	i2	4.130102k
EN61000-4-4	EMC TEST	4.10
EN61000-4-5	EMC Partner	1.69
EN61000-4-6	EMC Partner	2.22
EN61000-4-8	N/A	
EN61000-4-11	NOISE KEN	2.0

Site	Filename	Version	Issue Date
Conduction/Radiation	EZ EMC	ISL-03A2	3/6/2013

14.2 Appendix B: Uncertainty of Measurement

The measurement uncertainty refers to CISPR 16-4-2:2011. The coverage factor $k = 2$ yields approximately a 95 % level of confidence.

<Conduction 03>

AMN: $\pm 3.28\text{dB}$

<Chamber 12 (10M)>

Horizontal

30MHz~200MHz: $\pm 3.36\text{dB}$

200MHz~1000MHz: $\pm 3.93\text{dB}$

Vertical

30MHz~200MHz: $\pm 4.51\text{dB}$

200MHz~1000MHz: $\pm 4.02\text{dB}$

<Chamber 14 (3M)>

1GHz~6GHz: $\pm 4.64\text{dB}$

<Immunity 02>

Test item	Uncertainty	Test item	Uncertainty
EN61000-4-2 (ESD)		EN61000-4-5 (Surge)	
Rise time t_r	$\leq 15\%$	Time	$\pm 2.8\%$
Peak current I_p	$\leq 6.3\%$	Voltage	$\pm 1.6\%$
Current at 30 ns	$\leq 6.3\%$	Current	$\pm 1.6\%$
Current at 60 ns	$\leq 6.3\%$	EN61000-4-6 (CS)	
EN61000-4-3 (RS)	$\pm 2.19\text{dB}$	CDN	$\pm 1.36\text{dB}$
EN61000-4-4 (EFT)		EM Clamp	$\pm 3.19\text{dB}$
Voltage rise time (tr)	$\pm 6.2\%$	EN61000-4-8 (Magnetic)	$\pm 4.8\%$
Peak voltage value(VP)	$\pm 8.6\%$	EN61000-4-11 (Dips)	
Voltage pulse width (tw)	$\pm 5.9\%$	Time	$\pm 2.8\%$
		Voltage	$\pm 0.04\%$
		Current	$\pm 1.3\%$

Test item	Uncertainty	Test item	Uncertainty
EN61000-3-2 (Harmonics)	$\pm 3.98\%$	EN61000-3-3 (Fluctuations and Flicker)	$\pm 3.98\%$

14.3 Appendix C: Photographs of EUT

Please refer to the File of **ISL-14LE536P**

ISL
Draft