



EMC Test Report For:

Apacer Technology Inc.

EUT: PCIe Pi HAT SSD

**Model Number: PT25R-Pi HAT SSD, PX25R-Pi HAT SSD
(X=A~Z,0~9)**

Prepared for:

Apacer Technology Inc.

1F., No. 32, Zhongcheng Rd., Tucheng Dist., New Taipei City, Taiwan (R.O.C)

**Report By : Global EMC Standard Tech. Corp.
No.3, Baodoucuokeng, Linkou Dist.,
New Taipei City 244, Taiwan(R.O.C.)
Tel : 886-2-2603-5321
Fax: 886-2-2603-5325**

Test results given in this report only relate to the specimen(s) tested, measured.
This report is the property of Global EMC Standard Tech. Corp., and shall not be reproduced, other than in full, without the written consent of Global EMC Standard Tech. Corp...
The client should not use it to claim product endorsement by TAF or any government agencies.
All data in this report are traceable to national standard or international standard.

TABLE OF CONTENTS

Description	Page
1. CERTIFICATION	3
2. SUMMARY OF TEST RESULTS	4
2.1 UNCERTAINTY DESCRIPTION	5
3. GENERAL INFORMATION	6
3.1 PRODUCT DESCRIPTION	6
3.2 TEST MODES & EUT COMPONENTS DESCRIPTION	6
3.3 CONFIGURATION OF THE SYSTEM UNDER TEST	7
3.4 BLOCK DIAGRAM OF CONNECTIONS BETWEEN EUT AND SIMULATORS	8
3.5 REQUIREMENT AMBIENT	9
3.6 TEST FACILITY ACCREDITATION	9
4. CONDUCTED EMISSION MEASUREMENT	10
4.1 TEST EQUIPMENTS	10
4.2 TEST METHOD	10
4.3 BLOCK DIAGRAM OF TEST SETUP	10
4.4 CONDUCTED EMISSION LIMITS	11
4.5 TEST CONFIGURATION ON MEASUREMENT	11
4.6 CONDUCTED EMISSION MEASURED PROCEDURE AND DATA	11
4.7 OPERATING CONDITIONS OF THE EUT	11
4.8 CONDUCTED EMISSION MEASUREMENT RESULTS	12
5. RADIATED EMISSION MEASUREMENT	14
5.1 TEST EQUIPMENT	14
5.2 TEST METHOD	14
5.3 SETUP DIAGRAM	15
5.4 RADIATED EMISSION LIMITS	16
5.5 TEST CONFIGURATION	17
5.6 OPERATING CONDITIONS OF THE EUT	17
5.7 RADIATED EMISSION DATA	18
5.8 RADIATED EMISSIONS MEASUREMENT RESULTS	19
6. HARMONIC CURRENT EMISSIONS, VOLTAGE FLUCTUATIONS AND FLICKER MEASUREMENT	23
6.1 TEST EQUIPMENT	23
6.2 TEST METHOD	23
6.3 BLOCK DIAGRAM OF TEST SETUP	23
6.4 LIMITS OF HARMONIC CURRENT EMISSIONS AND FLICKER MEASUREMENT	24
6.5 OPERATING CONDITIONS OF THE EUT	24
6.6 TEST PROCEDURE	24
6.7 TEST RESULT	24
7. ESD IMMUNITY TEST	27
7.1 TEST EQUIPMENT	27
7.2 TEST METHOD	27
7.3 BLOCK DIAGRAM OF TEST SETUP	27
7.4 SEVERITY LEVELS	28
7.5 OPERATING CONDITIONS OF THE EUT	28
7.6 TEST PROCEDURE	28
7.7 TEST RESULT	29
8. RF FIELD STRENGTH SUSCEPTIBILITY TEST	30
8.1 TEST EQUIPMENT	30
8.2 TEST METHOD	30
8.3 BLOCK DIAGRAM OF TEST SETUP	31
8.4 SEVERITY LEVELS	31
8.5 OPERATING CONDITIONS OF THE EUT	31
8.6 TEST PROCEDURE	31
8.7 TEST RESULT	32
9. ELECTRICAL FAST TRANSIENT/BURST IMMUNITY TEST	33
9.1 TEST EQUIPMENT	33
9.2 TEST METHOD	33
9.3 BLOCK DIAGRAM OF TEST SETUP	33
9.4 SEVERITY LEVELS	34
9.5 OPERATING CONDITIONS OF THE EUT	34
9.6 TEST RESULT	34
10. SURGE IMMUNITY TEST	35
10.1 TEST EQUIPMENT	35
10.2 TEST METHOD	35
10.3 BLOCK DIAGRAM OF TEST SETUP	35
10.4 SEVERITY LEVELS	35
10.5 OPERATING CONDITIONS OF THE EUT	36
10.6 TEST PROCEDURE	36
10.7 TEST RESULT	37
11. CONDUCTED DISTURBANCE SUSCEPTIBILITY TEST	38
11.1 TEST EQUIPMENT	38
11.2 TEST METHOD	38
11.3 BLOCK DIAGRAM OF TEST SETUP	38
11.4 SEVERITY LEVELS	39
11.5 OPERATING CONDITIONS OF THE EUT	39
11.6 TEST PROCEDURE	39
11.7 TEST RESULT	40
12. MAGNETIC FIELD IMMUNITY MEASUREMENT	41
12.1 TEST EQUIPMENT	41
12.2 TEST METHOD	41
12.3 BLOCK DIAGRAM OF TEST SETUP	41
12.4 SEVERITY LEVELS	42
12.5 EUT OPERATION CONDITION	42
12.6 TEST PROCEDURE	42
12.7 TEST RESULT	43
13. VOLTAGE DIPS AND SHORT INTERRUPTIONS TEST	44
13.1 TEST EQUIPMENT	44
13.2 TEST METHOD	44
13.3 BLOCK DIAGRAM OF TEST SETUP	44
13.4 SEVERITY LEVELS	44
13.5 OPERATING CONDITIONS OF THE EUT	45
13.6 TEST PROCEDURE	45
13.7 TEST RESULT	46
14. PHOTOGRAPHS FOR TEST	48
14.1 TEST PHOTOGRAPHS FOR CONDUCTION	48
14.2 TEST PHOTOGRAPHS FOR RADIATED	49
14.3 TEST PHOTOGRAPHS FOR HARMONIC/FLICKER	51
14.4 TEST PHOTOGRAPHS FOR ESD	52
14.5 TEST PHOTOGRAPHS FOR ESD TEST POINTS	53
14.6 TEST PHOTOGRAPHS FOR RS	55
14.7 TEST PHOTOGRAPHS FOR EFT	57
14.8 TEST PHOTOGRAPHS FOR SURGE	58
14.9 TEST PHOTOGRAPHS FOR CS	59
14.10 TEST PHOTOGRAPHS FOR MAGNETIC	60
14.11 TEST PHOTOGRAPHS FOR DIPS	61
15. PHOTOGRAPHS FOR PRODUCT	62

1. CERTIFICATION

Applicant : Apacer Technology Inc.
EUT Description : PCIe Pi HAT SSD
Model Number : PT25R-Pi HAT SSD, PX25R-Pi HAT SSD (X=A~Z,0~9)
Serial Number : N/A
Brand Name : Apacer

STANDARDS OF TEST METHOD:

EN 55032:2015 +AC:2016 +A11:2020 +A1:2020 / CISPR 32:2015 + COR1:2016 + A1:2019
BS EN 55032:2015 +AC:2016 +A11:2020 +A1:2020
EN IEC 61000-3-2:2019 +A1:2021+A2: 2024
BS EN IEC 61000-3-2:2019 +A1:2021+A2: 2024
EN 61000-3-3:2013 +A1:2019 +A2:2021 +AC:2022
BS EN 61000-3-3:2013 +A1:2019 +A2:2021 +AC:2022
EN 55035:2017 + A11:2020 / CISPR 35: 2016_{AND} BS EN 55035:2017 + A11:2020
IEC 61000-4-2/IEC 61000-4-3/IEC 61000-4-4/IEC 61000-4-5/IEC 61000-4-6/IEC
61000-4-8/IEC 61000-4-11

GENERAL REMARKS:

The tests were performed according to the technical requirement of EUT.

- Electro-magnetic Radiated Emission Interference Measurement (EN 55032/CISPR 32)
- Electro-magnetic Conducted Emission Interference Measurement (EN 55032/CISPR 32)
- Harmonic Current Emissions (EN IEC 61000-3-2)
- Voltage Fluctuation and Flicker Measurement (EN 61000-3-3)
- ESD Immunity Test ((IEC 61000-4-2)
- RF Field strength Susceptibility Test (IEC 61000-4-3)
- Electrical Fast Transient/Burst Immunity Test (IEC 61000-4-4)
- Surge Immunity Test (IEC 61000-4-5)
- Conducted disturbance Susceptibility Test (IEC 61000-4-6)
- Power Frequency Magnetic Field Immunity Test (IEC 61000-4-8)
- Voltage Dips/Short Interruptions Test (IEC 61000-4-11)

Sample Received Data : December 23, 2025
Date of Test : December 23, 2025 - December 29, 2025
Issue Date : January 21, 2026

In order to ensure the quality and accuracy of this document, the contents have been thoroughly reviewed by the following qualified personnel from Global EMC Standard Tech. Corp..

Documented By:

Mandy Chen

Mandy Chen / Report Author

Approved By:

Frederic Fang

Frederic Fang / Assistant Manager

2. SUMMARY OF TEST RESULTS

(1) Test by Global EMC Standard Tech. Corp..

STANDARD	TEST ITEM	TEST RESULT	REMARKS
EN 55032:2015 +AC:2016 +A11:2020 +A1:2020/ CISPR 32:2015 + COR1:2016 + A1:2019 Class B	Conducted emission (Mode 1)	PASS	The worst emission frequency is <u>0.6809</u> MHz And minimum passing margin is <u>-12.89</u> dB
	Radiated emission- Below 1GHz (Mode 1)	PASS	The worst emission frequency is <u>40.1800</u> MHz at <u>Vertical</u> . And minimum passing margin is <u>-9.13</u> dB. Height of antenna is <u>100cm</u> . Angle of turntable is <u>137°</u> .
	Radiated emission- Above 1GHz (Mode 1)	PASS	The worst emission frequency is <u>5980.0900</u> MHz at <u>Horizontal</u> . And minimum passing margin is <u>-16.45</u> dB. Height of antenna is <u>100 cm</u> . Angle of turntable is <u>121°</u> .
EN 55035:2017 + A11:2020/CISPR 35: 2016 IEC 61000-4-2:2008	Electrostatic Discharge(ESD)	PASS	Contact discharge up to <u>±4kV</u> . Air discharge up to <u>±8kV</u> .
EN 55035:2017 + A11:2020/CISPR 35: 2016 IEC 61000-4-3: 2020	RF field strength Susceptibility	PASS	80-1000MHz (1kHz sinewave with 80% Amplitude Modulation: 3V/m)
EN 55035:2017 + A11:2020/CISPR 35: 2016 IEC 61000-4-4:2012	Electrical Fast Transients/Burst	PASS	±0.5kV, ±1.0kV (AC Input)
EN 55035:2017 + A11:2020/CISPR 35: 2016 IEC 61000-4-5: 2014+A1: 2017	Surge	PASS	±0.5kV, ±1kV, ±2kV ((AC Input)
EN 55035:2017 + A11:2020/CISPR 35: 2016 IEC 61000-4-6: 2023	Conducted Disturbance Susceptibility	PASS	0.15-10MHz (1kHz sinewave with 80% Amplitude Modulation: 3V) 10-30MHz (1kHz sinewave with 80% Amplitude Modulation: 3~1V) 30-80MHz (1kHz sinewave with 80% Amplitude Modulation: 1V)

STANDARD	TEST ITEM	TEST RESULT	REMARKS
EN 55035:2017 + A11:2020/CISPR 35: 2016 IEC 61000-4-8: 2009	Magnetic Field Measurement	PASS	1A/m at 50/60Hz
EN 55035:2017 + A11:2020/CISPR 35: 2016 IEC 61000-4-11:2020 +COR1:2020 +COR2:2022	Voltage short Interruptions	PASS	>95% reduction, 5s at 50/60Hz
	Voltage Dips		>95% reduction, 10 ms at 50Hz >95% reduction, 8.33 ms at 60Hz 30% reduction, 500 ms at 50/60Hz

(2) Test by Audix Technology Corporation.

STANDARD	TEST ITEM	TEST RESULT	REMARKS
EN IEC 61000-3-2:2019 +A1:2021+A2: 2024	Harmonic Current Emissions	PASS	EUT power level is below 75 Watts and therefore has no defined limits.
EN 61000-3-3:2013 + A1:2019 + A2:2021 + AC:2022	Voltage Fluctuation and Flicker Measurement	PASS	The Value of Pst shall not be greater than 1.0
EN 55035:2017 + A11:2020/CISPR 35: 2016 IEC 61000-4-3: 2020	RF field strength Susceptibility	PASS	1800, 2600, 3500, 5000MHz (1kHz sinewave with 80% Amplitude Modulation: 3V/m)

2.1 UNCERTAINTY DESCRIPTION

According to CISPR16-4-2, the MU of the laboratory is calculated as follows:

Measurement		GESTEK uncertainty
Conducted disturbance (mains port)	150 kHz ~ 30 MHz	4.0 dB.
Radiated disturbance (SAC)	30 MHz ~ 1000 MHz	3.7 dB.
Radiated disturbance (SAC)	1 GHz ~ 6 GHz	5.0 dB.

According to the description of EN 55032 Section 11, the above MU is not included in the calculation and judgment of the test results.

3. GENERAL INFORMATION

3.1 PRODUCT DESCRIPTION

Product Name : PCIe Pi HAT SSD
Model Number : PT25R-Pi HAT SSD, PX25R-Pi HAT SSD (X=A~Z,0~9)
Serial Number : N/A
Applicant : Apacer Technology Inc.
Address : 1F., No. 32, Zhongcheng Rd., Tucheng Dist., New Taipei City, Taiwan (R.O.C)
Manufacturer : Apacer Technology Inc.
Address : 1F., No. 32, Zhongcheng Rd., Tucheng Dist., New Taipei City, Taiwan (R.O.C)
Power Supply : DC 3.3V

3.2 TEST MODES & EUT COMPONENTS DESCRIPTION

EUT: PCIe Pi HAT SSD, M/N: PT25R-Pi HAT SSD, PX25R-Pi HAT SSD (X=A~Z,0~9)	
Test Mode	Mode 1- Full Load Read / Write (Worst Case)
Test Model Number	PT25R-Pi HAT SSD

Note:

1. According to pre-scan data, we determine the data (Mode 1) shown in this test report, which reflects the worst-case data for each operation mode.

3.3 CONFIGURATION OF THE SYSTEM UNDER TEST

Item	Device	No.	Configuration
1	PC System	GTK001	Manufacturer :HP Model Name :HP EliteDesk 800 G3 TWR BSMI ID : R3A304 VGA Card: GIGABYTE, M/N:GV-RX550D5-2GD(BSMI ID:D33006) WiFi and BT Card: Manufacturer :Realtek Model Name :RTL8723BE NCC ID:CCAF13LP0670T8 FCC ID:TX2-RTL8723BE
2	USB Keyboard	GTK026	Manufacturer : Logitech Model Number : YU0036 Serial Number : 2245SC300RY8 BSMI ID : D41126
3	USB Mouse	GTK023	Manufacturer : PHILIPS Model Number : SPK7234 Serial Number : SPB22100002480 BSMI ID : D39017
4	22" LCD DISPLAY	M01-092	Manufacturer : AOPEN Model Number : 22CL1Q E3bi Serial Number : MMA5ETT00153507AD63W01 BSMI ID : R33142 FCC ID : N/A AC Power Adaptor : M/N:1-CHUSB202-157 Input:AC IN:100V-240V,50/60Hz ,0.6A Output:DC 12V/2A

Note: All the peripherals above were selected specifically after confirming that there is no impact on test results.

3.4 BLOCK DIAGRAM OF CONNECTIONS BETWEEN EUT AND SIMULATORS

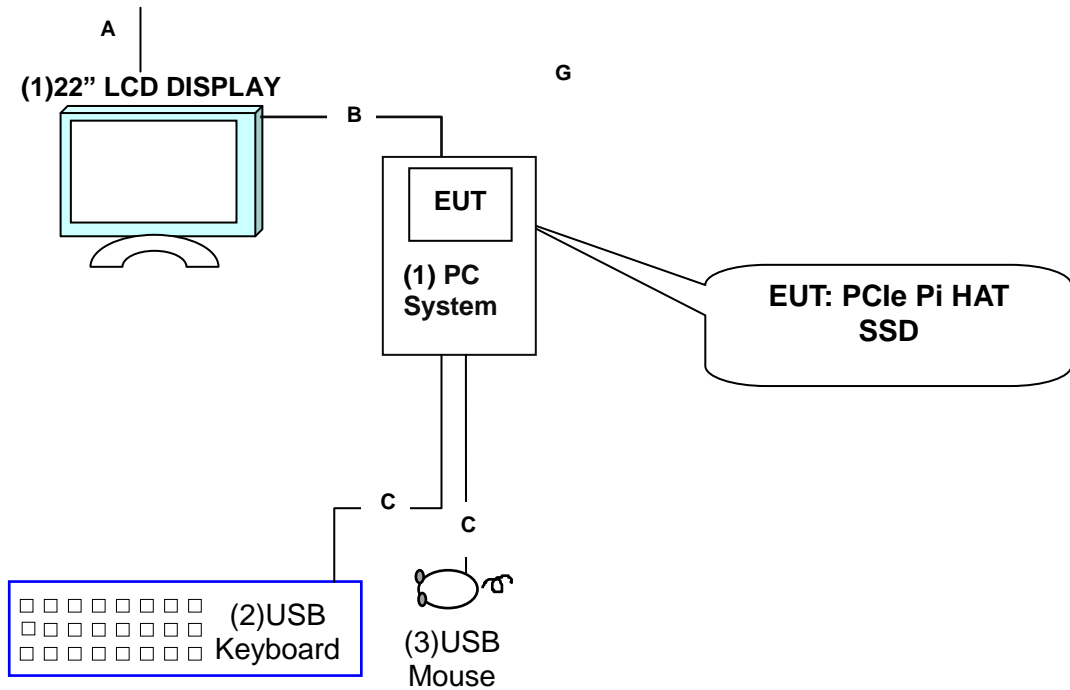

Signal Cable Description of the above support units				
No.	Signal Cable Description	Shielded	Core type	Length (m)
A	Power Cord*2	<input type="checkbox"/> Yes <input checked="" type="checkbox"/> No	<input checked="" type="checkbox"/> No <input type="checkbox"/> 1(near EUT) <input type="checkbox"/> 1(near Aux) <input type="checkbox"/> 2	1.8
B	D-SUB Cable	<input checked="" type="checkbox"/> Yes <input type="checkbox"/> No	<input type="checkbox"/> No <input type="checkbox"/> 1(near EUT) <input type="checkbox"/> 1(near Aux) <input checked="" type="checkbox"/> 2	1.8
C	USB Cable *2	<input type="checkbox"/> Yes <input checked="" type="checkbox"/> No	<input checked="" type="checkbox"/> No <input type="checkbox"/> 1(near EUT) <input type="checkbox"/> 1(near Aux) <input type="checkbox"/> 2	1.8

3.5 REQUIREMENT AMBIENT

Items	Range Requirement
Temperature (°C)	10-40
Humidity (%RH)	10-90
Barometric pressure (mbar)	860-1060

3.6 TEST FACILITY ACCREDITATION

Global EMC Standard Tech. Corp. is accredited in respect of laboratory and the accreditation criteria is ISO/IEC 17025: 2017.

Site Description : Registration on VCCI effective through February 18, 2027.
VCCI Member No.708

Recognized by the Council of Taiwan Accreditation Foundation
As an accredited laboratory and registration No.:1082.
Registration on TAF effective through Dec. 31, 2026.

Aug. 10, 1995 /Aug. 25, 1998 File on FCC Engineering Laboratory
Federal Communications Commission
Designation Number: TW1032

Name of firm : Global EMC Standard Tech. Corp.

Site location : No.3, Baodoucuokeng, Linkou Dist., New Taipei City 244, Taiwan (R.O.C.)



4. CONDUCTED EMISSION MEASUREMENT

4.1 TEST EQUIPMENTS

Item	Instrument	Manufacturer	Model	S/N or Version	Next Cal. Date
1	TEST RECEIVER	RS	ESCS30	100392	2026.03.05
2	LISN	RS	ENV216	100108	2026.03.05
3	RF CABLE	GTK	N/A	GTK-E-A154-01	2025.12.30
4	50 ohm Coaxial Switch	Anritsu	MP59B	6200712237	2026.02.13
5	Software	FARAD	EZ-EMC	2A1.1(USB)	N/A

Note: 1. All equipments are calibrated and will be valid only for a period of 1 year.

2. The test was performed at GTK Shielded Room A9.

4.2 TEST METHOD

According to EN 55032:2015 +AC:2016 +A11:2020 +A1:2020 /
 CISPR 32:2015 + COR1:2016 + A1:2019

4.3 BLOCK DIAGRAM OF TEST SETUP

4.3.1 TEST SETUP FOR EMISSION MEASUREMENT AT MAINS TERMINAL

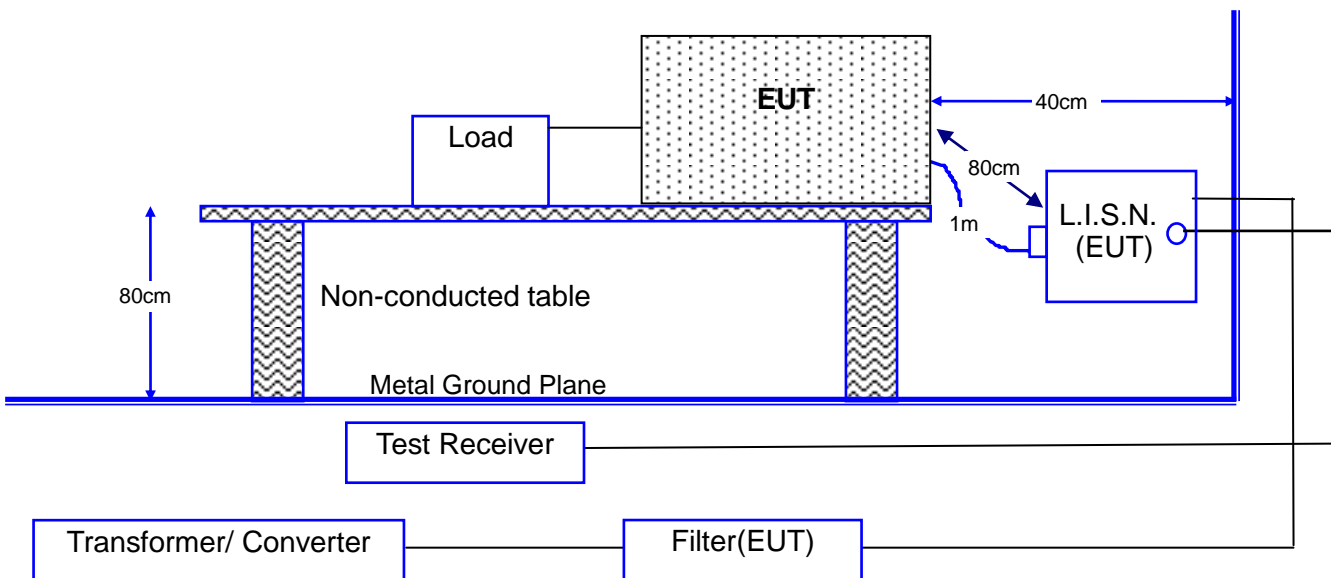

Note: This is a representative setup diagram for Table-top EUT.

For Floor-standing EUT, the table will be removed with all others setup condition remain the same.

4.4 CONDUCTED EMISSION LIMITS

4.4.1 Requirements for conducted emissions from the AC mains power ports

for class A equipment

Applicable to 1. AC mains power ports (3.1.1)				
Table clause	Frequency range MHz	Coupling device (see Table A.8)	Detector type / bandwidth	Class A limits dB(mV)
A9.1	0,15 to 0,5	AMN	Quasi Peak / 9 kHz	79
	0,5 to 30			73
A9.2	0,15 to 0,5	AMN	Average / 9 kHz	66
	0,5 to 30			60

Apply A9.1 and A9.2 across the entire frequency range.

for class B equipment

Applicable to 1. AC mains power ports (3.1.1)				
Table clause	Frequency range MHz	Coupling device (see Table A.8)	Detector type / bandwidth	Class B limits dB(mV)
A10.1	0,15 to 0,5	AMN	Quasi Peak / 9 kHz	66 to 56
	0,5 to 5			56
	5 to 30			60
A10.2	0,15 to 0,5	AMN	Average / 9 kHz	56 to 46
	0,5 to 5			46
	5 to 30			50

Apply A10.1 and A10.2 across the entire frequency range.

4.5 TEST CONFIGURATION ON MEASUREMENT

The equipments that are listed in section 4.1 are installed on Conducted Power Line Test in order to meet the requirement of the Commission and operating in a manner, which tends to maximize its emission characteristics in a normal application.

The device under test, installed in a representative system as described in section 4.3, was placed on a non-conductive table whose total height equal to 80cm. Powered from one L.I.S.N. which signal output to receiver, and the other peripherals was powered from another L.I.S.N. which signal output was terminated by 50Ω.

4.6 CONDUCTED EMISSION MEASURED PROCEDURE AND DATA

4.6.1 CONDUCTED EMISSION (MAINS TERMINAL)

The measurement range of conducted emission, which is from 0.15 MHz to 30 MHz, was scan for peak emission curve of all the test modes. The worst mode is then measured using an average and/or quasi peak detector and record at least the disturbance levels and the frequencies of the six highest disturbances. The final measurement value is equal to the receiver reading plus the correction factor. If AMN insertion loss is more than 0.5dB, automatically the receiver will add the correction factor to the reading level.

4.7 OPERATING CONDITIONS OF THE EUT

The exercise program used during conducted emission measurement was designed to exercise the EUT in a manner similar to a typical use. The exercise sequence is listed as below:

1. Setup the EUT and simulators as shown on 4.3.
2. Turn on the power of all equipments.
3. Connect the notebook and USB read and write.
4. Start test.

4.8 CONDUCTED EMISSION MEASUREMENT RESULTS

Date of Test	December 24, 2025	Temperature	21.5 °C
EUT	PCIe Pi HAT SSD	Humidity	52.6 %
Test Mode	Mode 1	Display Pattern	Program
Test Power Supply	DC 3.3V (by PC)		

Line

No.	Frequency MHz	Reading Level dBµV	Factor dB	Measurement dBµV	Limit dBµV	Over Limit dB	Detector
1	0.2262	36.14	9.68	45.82	62.59	-16.77	QP
2	★0.2262	26.30	9.68	35.98	52.59	-16.61	AVG
3	0.2475	33.83	9.68	43.51	61.84	-18.33	QP
4	0.2475	18.28	9.68	27.96	51.84	-23.88	AVG
5	0.3753	28.61	9.67	38.28	58.38	-20.10	QP
6	0.3753	18.68	9.67	28.35	48.38	-20.03	AVG
7	0.5432	26.31	9.67	35.98	56.00	-20.02	QP
8	0.5432	17.64	9.67	27.31	46.00	-18.69	AVG
9	0.6776	26.11	9.67	35.78	56.00	-20.22	QP
10	0.6776	17.69	9.67	27.36	46.00	-18.64	AVG
11	25.4924	27.67	10.03	37.70	60.00	-22.30	QP
12	25.4924	20.37	10.03	30.40	50.00	-19.60	AVG

Remarks :

1. All readings are Quasi-peak and Average values.
2. Measurement = Reading + Factor (Could have ±0.01 tolerance due to computer automatically round off calculation).
3. Over Limit (Margin Value)=Measurement level-Limit value.
4. Factor = L.I.S.N. insertion loss + cable loss
5. “ ★ ” means that this data is the worse case measurement level.
6. The measurement uncertainty is 4.0 dB.

Line

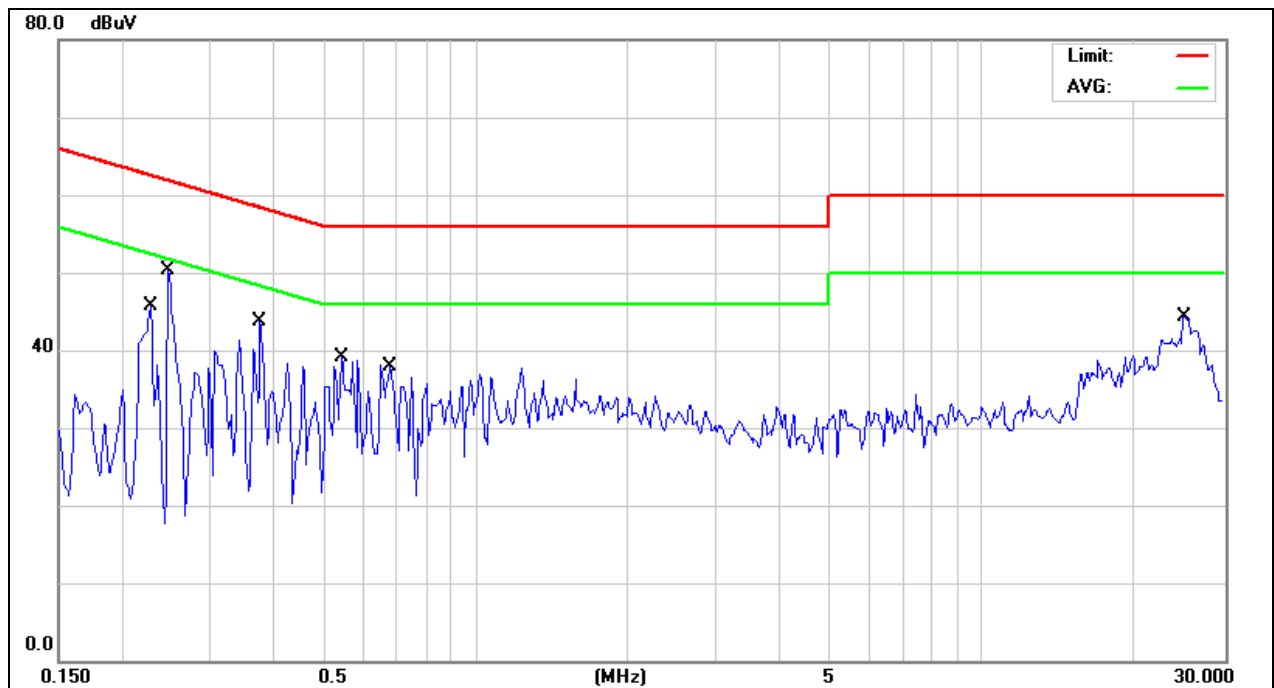

- Remark:
1. The Limit (The red line of the graph indicates the quasi-peak measurements).
 2. The AVG (The purple line of the graph indicates the average measurements).
 3. The scan curve indicates peak detector measurement.

Date of Test	November 28, 2025	Temperature	22.1 °C
EUT	PCIe Pi HAT SSD	Humidity	63.8 %
Test Mode	Mode 1	Display Pattern	Program
Test Power Supply	DC 3.3V (by PC)		

Neutral

No.	Frequency MHz	Reading Level dBµV	Factor dB	Measurement dBµV	Limit dBµV	Over Limit dB	Detector
1	0.2240	35.01	9.67	44.68	62.67	-17.99	QP
2	0.2240	21.53	9.67	31.20	52.67	-21.47	AVG
3	0.2380	31.68	9.67	41.35	62.17	-20.82	QP
4	0.2380	23.20	9.67	32.87	52.17	-19.30	AVG
5	0.6809	26.90	9.66	36.56	56.00	-19.44	QP
6	★0.6809	23.45	9.66	33.11	46.00	-12.89	AVG
7	0.7364	23.56	9.67	33.23	56.00	-22.77	QP
8	0.7364	22.63	9.67	32.30	46.00	-13.70	AVG
9	1.6198	26.84	9.67	36.51	56.00	-19.49	QP
10	1.6198	22.01	9.67	31.68	46.00	-14.32	AVG
11	3.0479	25.37	9.70	35.07	56.00	-20.93	QP
12	3.0479	18.31	9.70	28.01	46.00	-17.99	AVG

Remarks :

1. All readings are Quasi-peak and Average values.
2. Measurement = Reading + Factor (Could have ±0.01 tolerance due to computer automatically round off calculation).
3. Over Limit (Margin Value)=Measurement level-Limit value.
4. Factor = L.I.S.N. insertion loss + cable loss
5. " ★ " means that this data is the worse case measurement level.
6. The measurement uncertainty is 4.0 dB.

Neutral

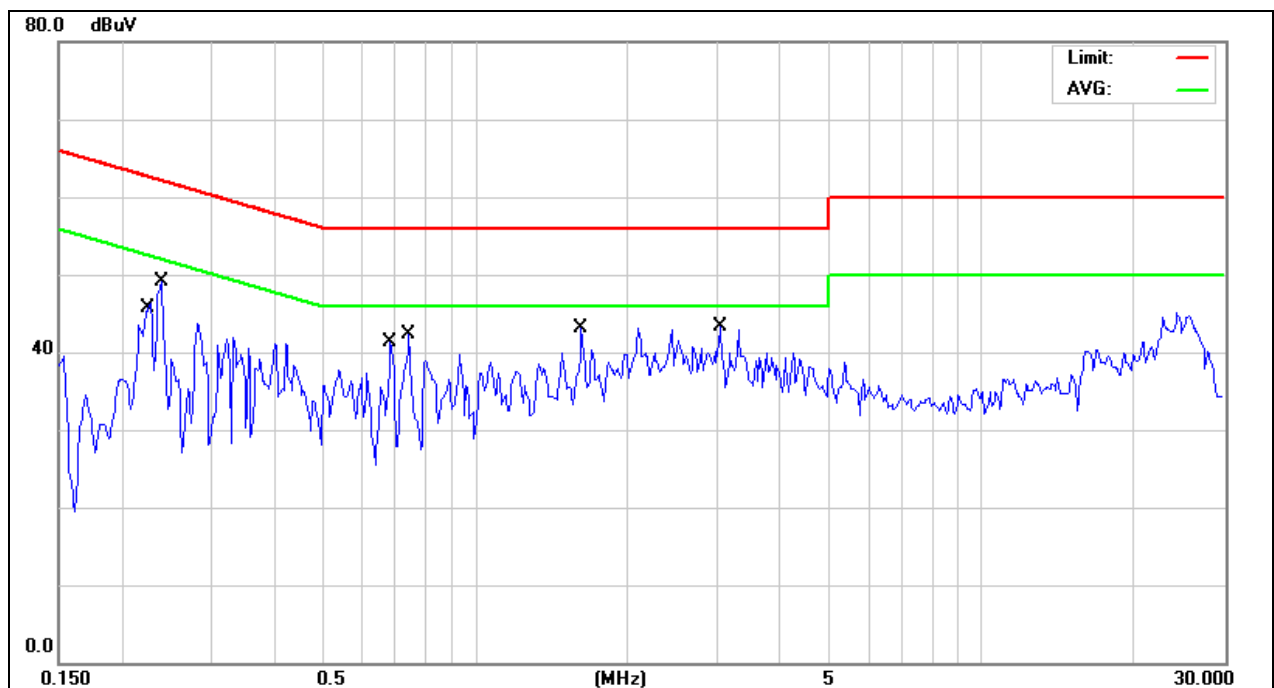

- Remark:
1. The Limit (The red line of the graph indicates the quasi-peak measurements).
 2. The AVG (The purple line of the graph indicates the average measurements).
 3. The scan curve indicates peak detector measurement.

5. RADIATED EMISSION MEASUREMENT

5.1 TEST EQUIPMENT

The following test equipments are used during the radiated emission tests:

Item	Instrument	Manufacturer	Model	S/N or Version	Next Cal. Date
1	TEST RECEIVER	RS	ESCS30	100393	2026.04.22
2	SPECTRUM	RS	FSV30	103799	2026.03.05
3	PRE-AMPLIFIER	HP	8447D	2944A08610	2026.03.04
4	PRE-AMPLIFIER	HP	8449B	3008A01264	2026.03.03
5	Trilog-Broadband Antenna	SCHWARZBECK	VULB 9168	9168-251	2026.07.03
6	with 5dB PAD	JYBAO	FAT-NM5NF5T3 G2W5	N/A	
	HORN ANTENNA	SCHWARZBECK	BBHA 9120	473	2026.03.03
7	50 ohm Coaxial Switch	Anritsu	MP59B	6200492883	2026.04.01
8	CABLE	GTK	N/A	GTK-E-A344-01	2026.04.01
9	CABLE	GTK	N/A	GTK-E-A346-01	2026.04.01
10	CABLE	INSULATED WIRE INC.	SPS-2801-3940-NPS	03262012	2026.03.05
11	CABLE	SUHNER	SUCOFLEX 104PEA	MY3501/4PEA	2026.07.02
12	Software	FARAD	EZ-EMC	2A1.5(USB)	N/A

Note: 1. All equipments are calibrated and will be valid only for a period of 1 year.

2. The test was performed at GTK Open Site A1 (Under 1GHz) and Chamber A6 (Above 1GHz).

5.2 TEST METHOD

According to EN 55032:2015 +AC:2016 +A11:2020 +A1:2020 /
 CISPR 32:2015 + COR1:2016 + A1:2019

5.3 SETUP DIAGRAM

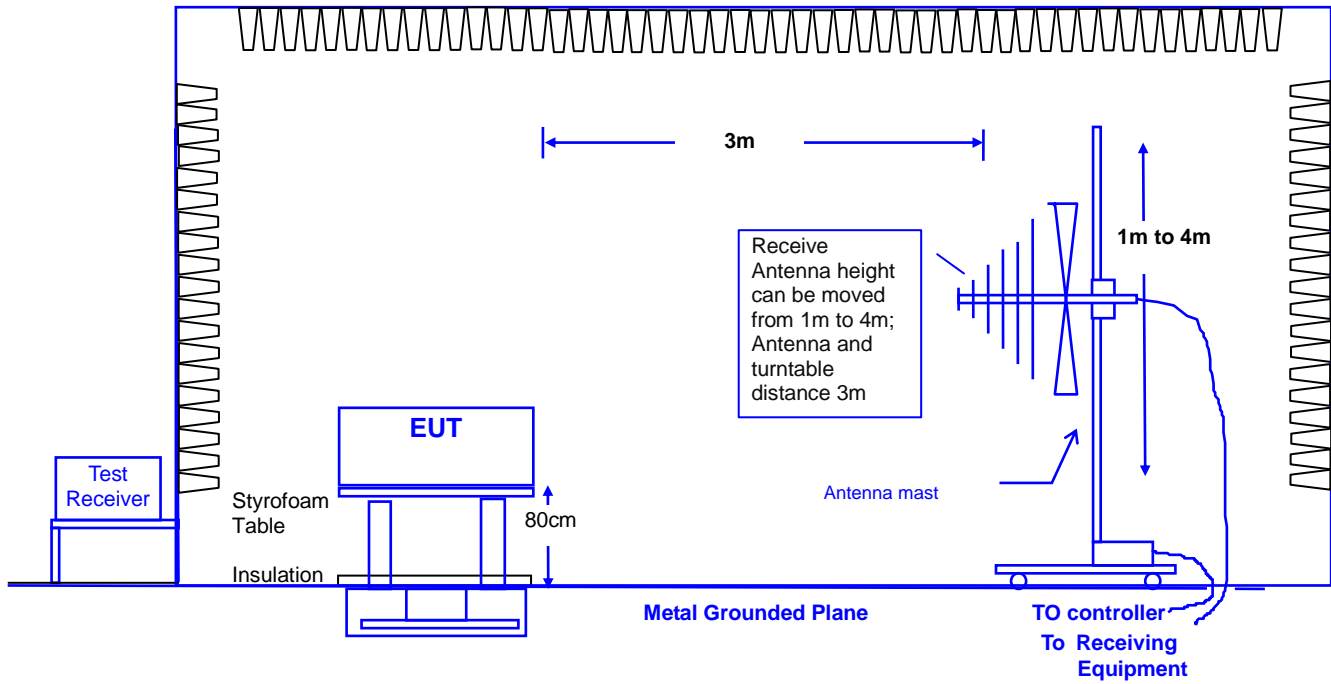

Note: This is a representative setup diagram for Table-top EUT.
 For Floor-standing EUT, the table will be removed with all the other setup conditions remain the same.

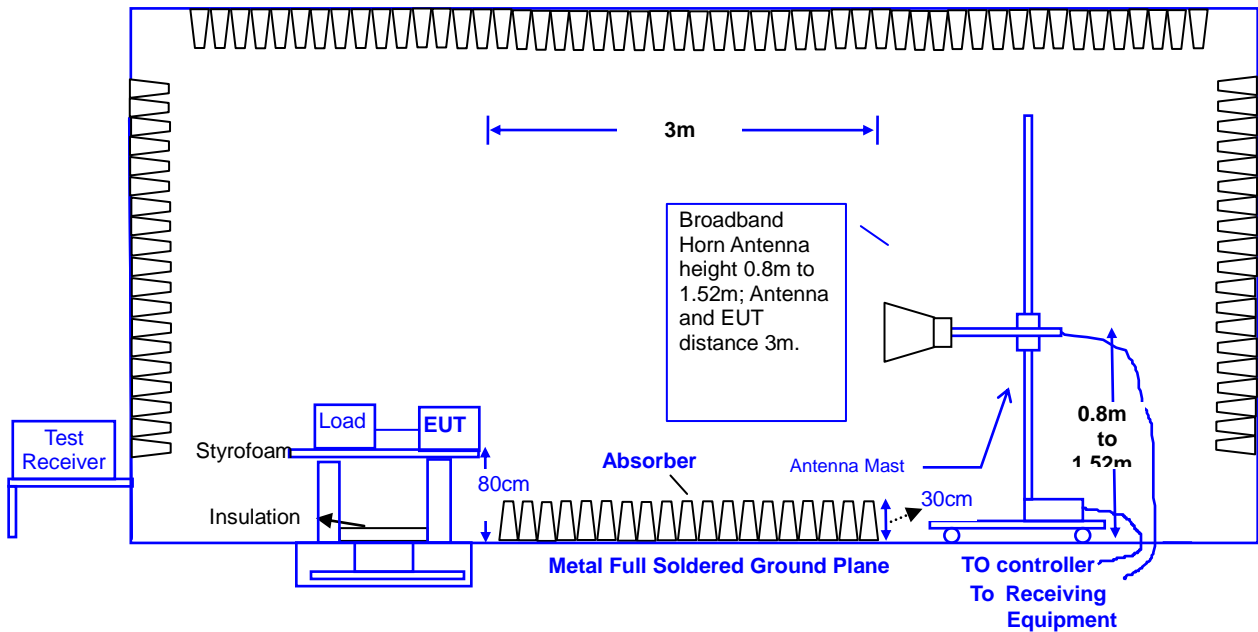

Note: This is a representative setup diagram for Table-top EUT.
 For Floor-standing EUT, the table will be removed with all others setup condition remain the same.

5.4 RADIATED EMISSION LIMITS

5.4.1 Requirements for radiated emissions at frequencies up to 1 GHz

for class A equipment

Table clause	Frequency range MHz	Measurement			Class A limits dB(mV/m)
		Facility (see Table A.1)	Distance m	Detector type /bandwidth	
A2.1	30 to 230	OATS/SAC	10	Quasi Peak / 120 kHz	40
	230 to 1 000				47
A2.2	30 to 230	OATS/SAC	3		50
	230 to 1 000				57
A2.3	30 to 230	FAR	10	Quasi Peak / 120 kHz	42 to 35
	230 to 1 000				42
A2.4	30 to 230	FAR	3		52 to 45
	230 to 1 000				52

Apply only A2.1 or A2.2 or A2.3 or A2.4 across the entire frequency range.

for class B equipment

Table clause	Frequency range MHz	Measurement			Class B limits dB(mV/m)
		Facility (see Table A.1)	Distance m	Detector type /bandwidth	
A4.1	30 to 230	OATS/SAC	10	Quasi Peak / 120 kHz	30
	230 to 1 000				37
A4.2	30 to 230	OATS/SAC	3		40
	230 to 1 000				47
A4.3	30 to 230	FAR	10	Quasi Peak / 120 kHz	32 to 25
	230 to 1 000				32
A4.4	30 to 230	FAR	3		42 to 35
	230 to 1 000				42

Apply only table clause A4.1 or A4.2 or A4.3 or A4.4 across the entire frequency range.

These requirements are not applicable to the local oscillator and harmonics frequencies of equipment covered by Table A.6.

5.4.1 Requirements for radiated emissions at frequencies above 1 GHz

for class A equipment

Table clause	Frequency range MHz	Measurement			Class A limits dB(mV/m)
		Facility (see Table A.1)	Distance m	Detector type / bandwidth	
A3.1	1 000 to 3 000	FSOATS	3	Average / 1 MHz	56
	3 000 to 6 000				60
A3.2	1 000 to 3 000			Peak / 1 MHz	76
	3 000 to 6 000				80

Apply A3.1 and A3.2 across the frequency range from 1 000 MHz to the highest required frequency of measurement derived from Table 1.

for class B equipment

Table clause	Frequency range MHz	Measurement			Class B limits dB(mV/m)
		Facility (see Table A.1)	Distance m	Detector type/bandwidth	
A5.1	1 000 to 3 000	FSOATS	3	Average/ 1 MHz	50
	3 000 to 6 000				54
A5.2	1 000 to 3 000			Peak/ 1 MHz	70
	3 000 to 6 000				74

Apply A5.1 and A5.2 across the frequency range from 1 000 MHz to the highest required frequency of measurement derived from Table 1.

5.5 TEST CONFIGURATION

The equipments which are listed at 5.1 are installed at the Radiated Emission Test site to meet the Commission requirements and operated in a manner, which tends to maximize its emission characteristics in a normal application.

The EUT, installed in a representative system as described in section 5.3, was placed on a non-conductive table whose total height equaled 80 cm. This table can be rotated 360 degrees.

5.5.1 30 MHz to 1 GHz

The measurement antenna was mounted to a non-conductive mast capable of moving the antenna vertically. Antenna height was varied from 1 m to 4 m and the system under test was rotated from 0 degree through 360 degrees relative to the antenna position and polarization (Horizontal and Vertical). Also the I/O cable positions were investigated to find the maximum emission condition.

5.5.2 Above 1 GHz

The measurement antenna was mounted to a non-conductive mast capable of moving the antenna vertically. The 1 GHz to 6 GHz minimum dimension of line tangent to the EUT formed by θ_{3dB} at the measurement distance 3 m is 1.44 m. For any EUT with maximum dimensions small than 1.44 m, the receive antenna shall be fixed at the height of the centre of the EUT.

The EUT height is 18 cm. The receive antenna height shall be table height added half of the EUT height equal to 89 cm. And the system under test was rotated from 0 degree through 360 degrees relative to the antenna position and polarization (Horizontal and Vertical). Also the I/O cable positions were investigated to find the maximum emission condition.

5.6 OPERATING CONDITIONS OF THE EUT

Same as conducted emission measurement, which is listed in 4.7

5.7 RADIATED EMISSION DATA

According EN55032, the lowest radio frequency signal generated or used in the device, without going below the lowest frequency for which a radiated emission limit is specified, up to the frequency shown in the following table:

Highest frequency of the internal sources of the EUT (MHz)	Upper frequency of measurement rang (MHz)
<108	1000
108-500	2000
500-1000	5000
Above 1000	5 th harmonic of the highest frequency or 6 GHz, whichever is less

Remark: The highest tested frequency is generated by the **10 GHz**.
At least, the upper frequency of measurement range is **6GHz**.

5.7.1 30 MHz to 1 GHz

The measurement range of radiated emission, which is from **30 MHz to 1 GHz**, was investigated. All readings are quasi-peak values with a resolution bandwidth of 120 kHz. The initial step in collecting radiated emission data is a spectrum analyzer peak scans of the measurement range for all the test modes and then use test receiver for final measurement and record at least the disturbance levels and the frequencies of the six highest disturbances. Then the worst modes were reported the following data pages.

5.7.2 Above 1 GHz

The measurement range of radiated emission, which is from **1 GHz to 6 GHz**, was investigated. All readings with a resolution bandwidth of 1 MHz. Use spectrum analyzer for final peak and average measurement and record at least the disturbance levels and the frequencies of the six highest disturbances. Then the worst modes were reported the following data pages.

5.8 RADIATED EMISSIONS MEASUREMENT RESULTS

Date of Test	December 23, 2025	Temperature	20.8 deg/C
EUT	PCIe Pi HAT SSD	Humidity	51.7 %RH
Working Cond.	Mode 1	Display Pattern	Program
Antenna distance	3m at Horizontal	Test Frequency Range	30-1000MHz
Test Power Supply	DC 3.3V (by PC)		

No.	Frequency MHz	Reading Level dBμV	Factor dB	Measurement dBμV/m	Limit dBμV/m	Over Limit dB	Detector
1	106.1500	38.15	- 12.70	25.45	40.00	- 14.55	QP
2	144.1500	37.46	- 8.93	28.53	40.00	- 11.47	QP
3	151.9800	35.06	- 8.57	26.49	40.00	- 13.51	QP
4	166.2700	34.18	- 8.56	25.62	40.00	- 14.38	QP
5	498.9500	30.60	- 2.63	27.97	47.00	- 19.03	QP
6	775.0500	26.25	3.61	29.86	47.00	- 17.14	QP
7	972.6700	25.11	7.02	32.13	47.00	- 14.87	QP

Remarks:

1. All Readings below 1GHz are Quasi-Peak.
2. Measurement = Reading + Factor (Could have ±0.01 tolerance due to computer automatically round off calculation).
3. Over Limit (Margin Value)=Measurement level-Limit value.
4. Factor = antenna factor + cable loss – amplifier gain.
5. “ ★ ” means that this data is the worse case measurement level.
6. The antenna height could have ±1cm tolerance and the turn table degree could have ±1° tolerance.
7. The measurement uncertainty is 3.7 dB.

80.0 dBμV/m

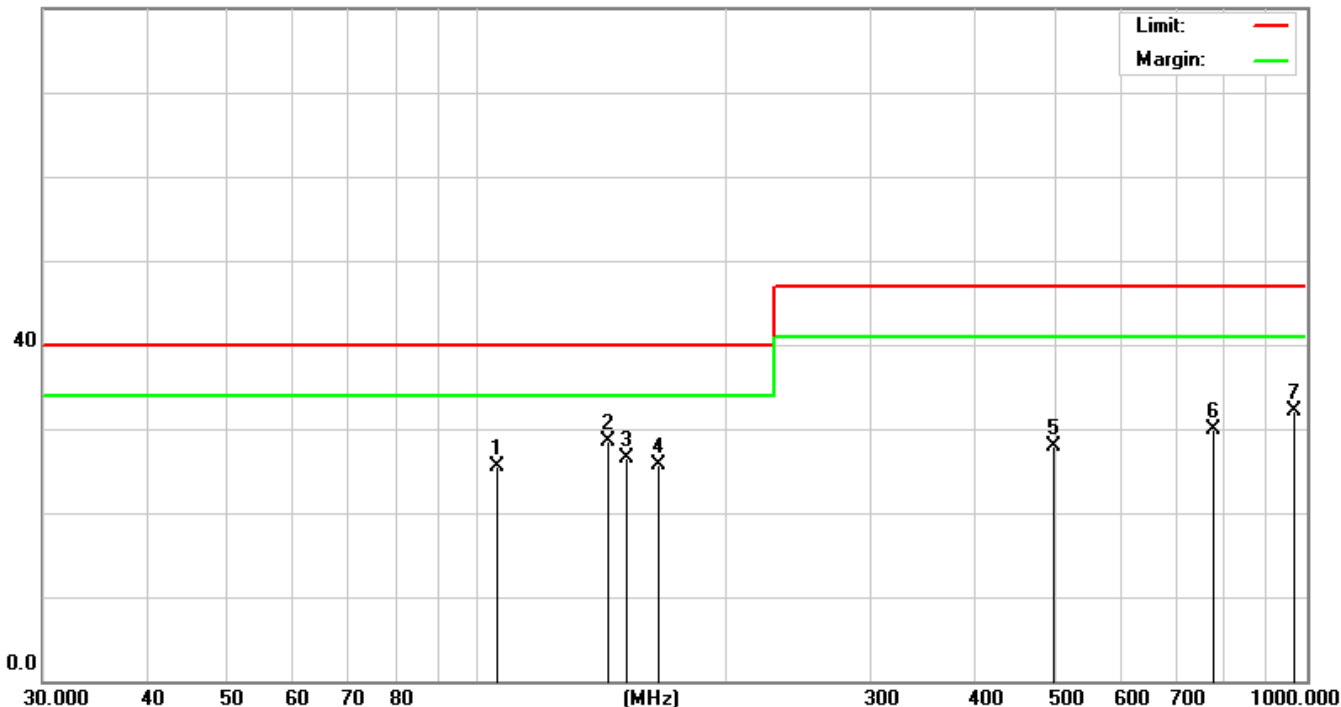

- Remark:
1. The Limit (The red line of the graph indicates the quasi -peak measurements).
 2. The Margin (The green line of the graph indicates the 6dB margin).

Date of Test	December 23, 2025	Temperature	20.8 deg/C
EUT	PCIe Pi HAT SSD	Humidity	51.7 %RH
Working Cond.	Mode 1	Display Pattern	Program
Antenna distance	3m at Vertical	Test Frequency Range	30-1000MHz
Test Power Supply	DC 3.3V (by PC)		

No.	Frequency MHz	Reading Level dB μ V	Factor dB	Measurement dB μ V/m	Limit dB μ V/m	Over Limit dB	Detector
1	30.2150	40.15	-11.46	28.69	40.00	-11.31	QP
2	★40.1800	41.06	-10.19	30.87	40.00	-9.13	QP
3	106.0250	38.25	-12.73	25.52	40.00	-14.48	QP
4	139.5170	37.15	-9.37	27.78	40.00	-12.22	QP
5	166.0200	33.06	-8.52	24.54	40.00	-15.46	QP
6	499.5200	38.19	-2.64	35.55	47.00	-11.45	QP
7	996.5270	28.15	7.46	35.61	47.00	-11.39	QP

Remarks:

1. All Readings below 1GHz are Quasi-Peak.
2. Measurement = Reading + Factor (Could have ± 0.01 tolerance due to computer automatically round off calculation).
3. Over Limit (Margin Value)=Measurement level-Limit value.
4. Factor = antenna factor + cable loss – amplifier gain.
5. “★” means that this data is the worse case measurement level.
6. The antenna height could have ± 1 cm tolerance and the turn table degree could have $\pm 1^\circ$ tolerance.
7. The measurement uncertainty is 3.7 dB.

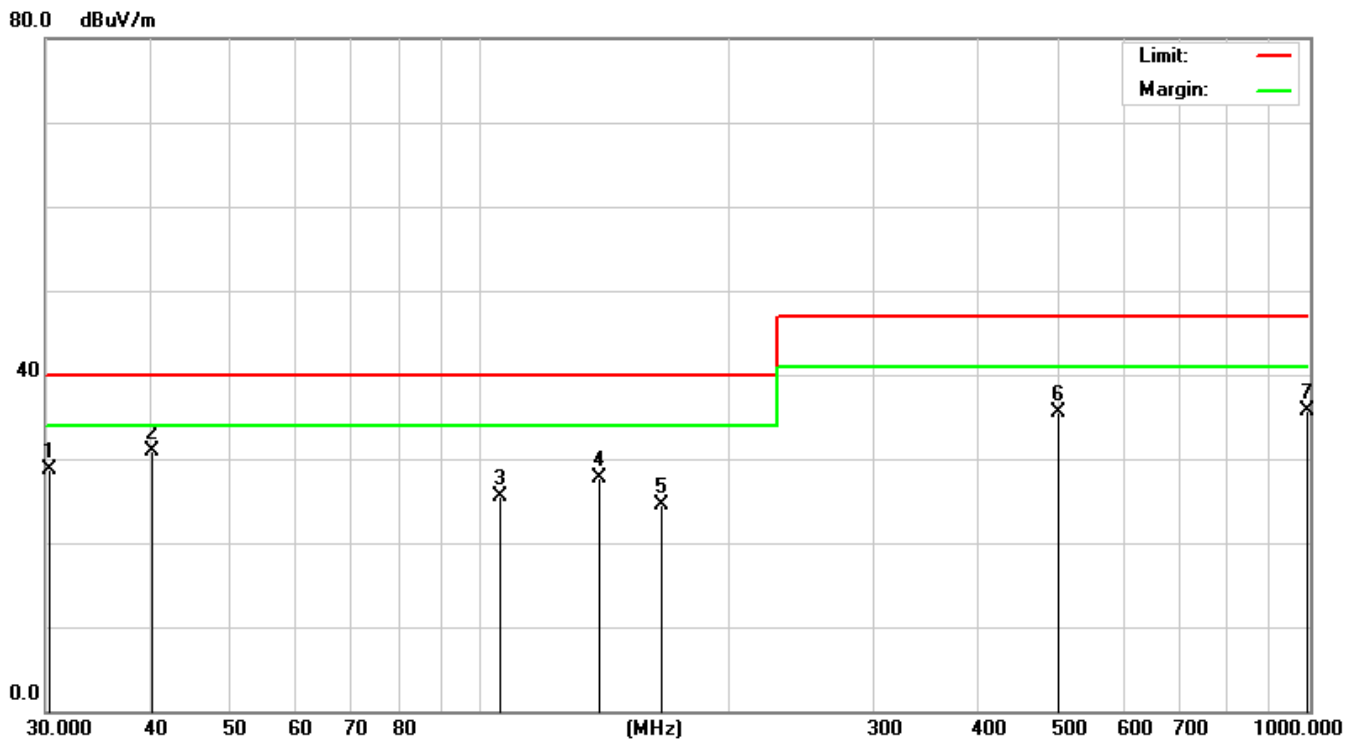

- Remark:
1. The Limit (The red line of the graph indicates the quasi -peak measurements).
 2. The Margin (The green line of the graph indicates the 6dB margin).

Date of Test	December 29, 2025	Temperature	22.4 deg/C
EUT	PCIe Pi HAT SSD	Humidity	52.6 %RH
Working Cond.	Mode 1	Display Pattern	Program
Antenna distance	3m at Horizontal	Test Frequency Range	1GHz~6GHz
Test Power Supply	DC 3.3V (by PC)		

No.	Frequency MHz	Reading Level dBμV	Factor dB/m	Measurement dBμV/m	Limit dBμV/m	Over Limit dB	Detector
1	1733.1050	49.15	-9.00	40.15	74.00	-33.85	peak
2	1733.1050	38.09	-9.00	29.09	54.00	-24.91	AVG
3	1972.5100	50.33	-7.41	42.92	74.00	-31.08	peak
4	1972.5100	40.27	-7.41	32.86	54.00	-21.14	AVG
5	2480.0600	46.62	-5.53	41.09	74.00	-32.91	peak
6	2480.0600	35.19	-5.53	29.66	54.00	-24.34	AVG
7	2733.0900	49.35	-4.95	44.40	74.00	-29.60	peak
8	2733.0900	38.47	-4.95	33.52	54.00	-20.48	AVG
9	3133.4000	46.33	-4.42	41.91	74.00	-32.09	peak
10	3133.4000	35.66	-4.42	31.24	54.00	-22.76	AVG
11	5980.0900	47.18	1.47	48.65	74.00	-25.35	peak
12	5980.0900	36.08	1.47	37.55	54.00	-16.45	AVG

Remarks:

- All Readings are Peak and Average value.
- Measurement = Reading + Factor (Could have ±0.01 tolerance due to computer automatically round off calculation).
- Over Limit (Margin Value)=Measurement level-Limit value.
- Factor = antenna factor + cable loss - amplifier gain + Coaxial Switch.
- The antenna height could have ±1cm tolerance and the turn table degree could have ±1° tolerance.
- The measurement uncertainty is 5.0 dB.

97.0 dBμV/m

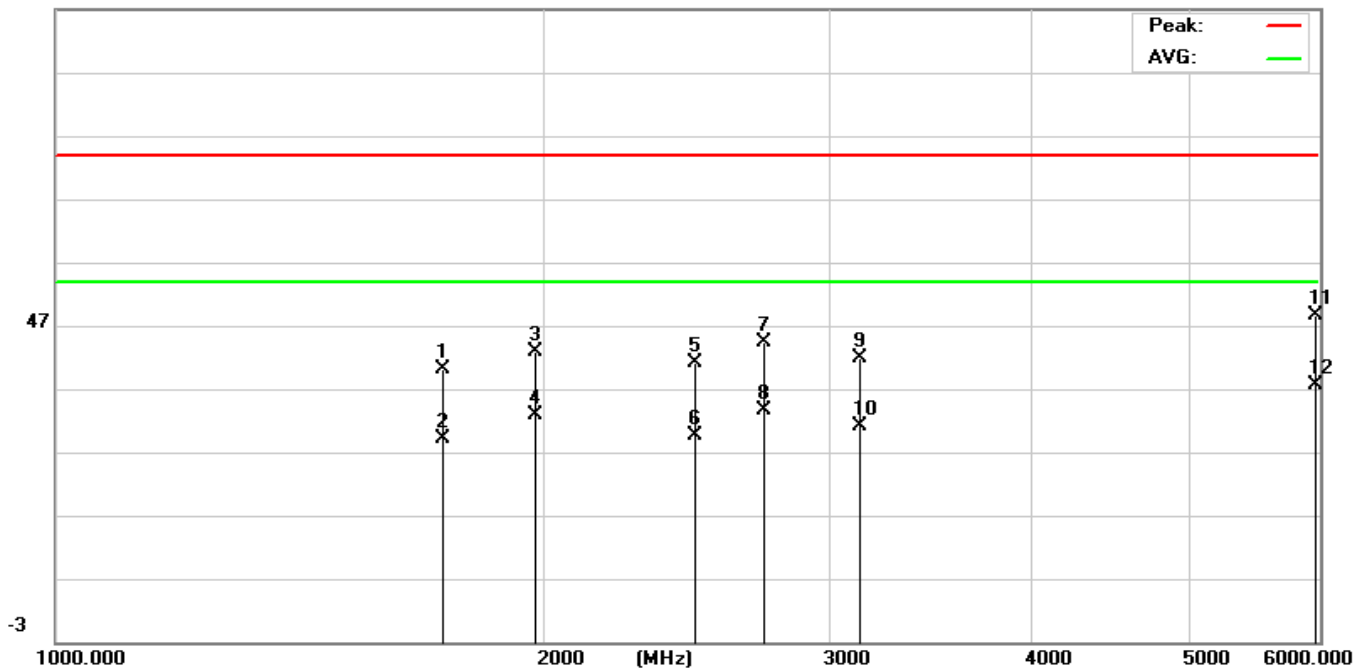

- Remark:
- The Peak (The red line of the graph indicates the peak measurements).
 - The AVG (The purple line of the graph indicates the average measurements).
 - The frequency range indicated in this graph is just a frequency range set automatically by the test equipment. The tested frequency range is mention in above column of the test data table.

Date of Test	December 29, 2025	Temperature	22.4 deg/C
EUT	PCIe Pi HAT SSD	Humidity	52.6 %RH
Working Cond.	Mode 1	Display Pattern	Program
Antenna distance	3m at Vertical	Test Frequency Range	1GHz~6GHz
Test Power Supply	DC 3.3V (by PC)		

No.	Frequency MHz	Reading Level dBμV	Factor dB/m	Measurement dBμV/m	Limit dBμV/m	Over Limit dB	Detector
1	1645.0200	48.52	-9.52	39.00	74.00	-35.00	peak
2	1645.0200	37.15	-9.52	27.63	54.00	-26.37	AVG
3	1733.0600	49.37	-9.00	40.37	74.00	-33.63	peak
4	1733.0600	38.06	-9.00	29.06	54.00	-24.94	AVG
5	1996.3400	48.27	-7.33	40.94	74.00	-33.06	peak
6	1996.3400	36.85	-7.33	29.52	54.00	-24.48	AVG
7	2433.0500	48.50	-5.76	42.74	74.00	-31.26	peak
8	2433.0500	37.18	-5.76	31.42	54.00	-22.58	AVG
9	2480.0600	49.27	-5.53	43.74	74.00	-30.26	peak
10	2480.0600	38.19	-5.53	32.66	54.00	-21.34	AVG
11	2646.1900	49.66	-5.10	44.56	74.00	-29.44	peak
12	2646.1900	39.06	-5.10	33.96	54.00	-20.04	AVG

Remarks:

- All Readings are Peak and Average value.
- Measurement = Reading + Factor (Could have ±0.01 tolerance due to computer automatically round off calculation).
- Over Limit (Margin Value)=Measurement level-Limit value.
- Factor = antenna factor + cable loss - amplifier gain + Coaxial Switch.
- The antenna height could have ±1cm tolerance and the turn table degree could have ±1° tolerance.
- The measurement uncertainty is 5.0 dB.

97.0 dBμV/m

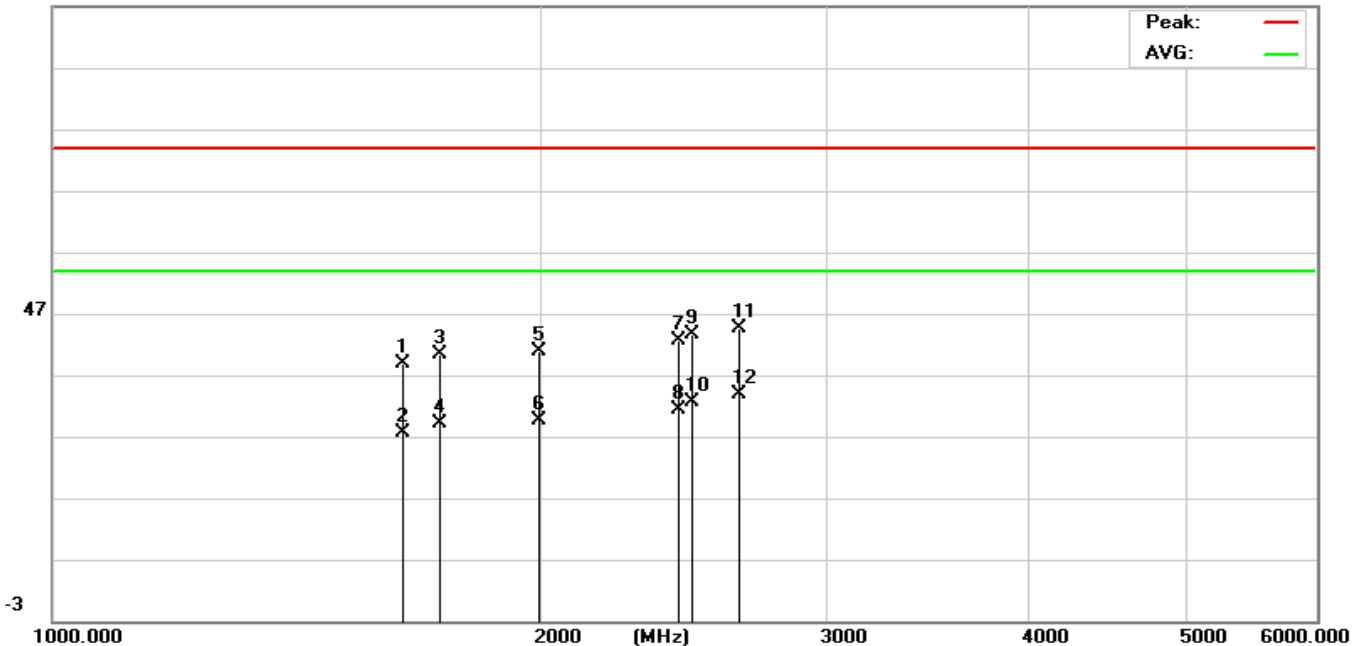

- Remark:
- The Peak (The red line of the graph indicates the peak measurements).
 - The AVG (The purple line of the graph indicates the average measurements).
 - The frequency range indicated in this graph is just a frequency range set automatically by the test equipment. The tested frequency range is mention in above column of the test data table.

6. HARMONIC CURRENT EMISSIONS, VOLTAGE FLUCTUATIONS AND FLICKER MEASUREMENT

6.1 TEST EQUIPMENT

Item	Instrument	Manufacturer	Model	S/N or Version	Next Cal. Date
1	45kVA AC/DC Power Source	TESEQ	NSG 1007-45	1248A04038	2026. 02. 10
2	Signal Conditioning Unit	TESEQ	CCN 1000-3	1234A03680	2026. 02. 10
3	Three Phase Impedance Network	TESEQ	INA 2197	1234A03681	2026. 02. 10
4	Proflin AC Switching Unit	TESEQ	NSG 2200-3	EK 22713	2026. 02. 10
5	Digital Thermo-Hygro Meter	iMax	HTC-1	No.2 Harmonics	2026. 04. 08
6	Test Software	California Instrument	CTS MXL	V2.26.0	N.C.R.

Note: 1. All equipments are calibrated and will be valid only for a period of 1 year.

2. The test was performed at Audix Technology Corporation No.2 Harmonics..

6.2 TEST METHOD

According to EN IEC 61000-3-2:2019 +A1:2021+A2: 2024

(Note: EUT power level is below 75 Watts and therefore has no defined limits)

EN 61000-3-3:2013 + A1:2019 + A2:2021 + AC:2022.

6.3 BLOCK DIAGRAM OF TEST SETUP

Note: This is a representative setup diagram for Table-top EUT.

For Floor-standing EUT, the table will be removed with all others setup condition remain the same.

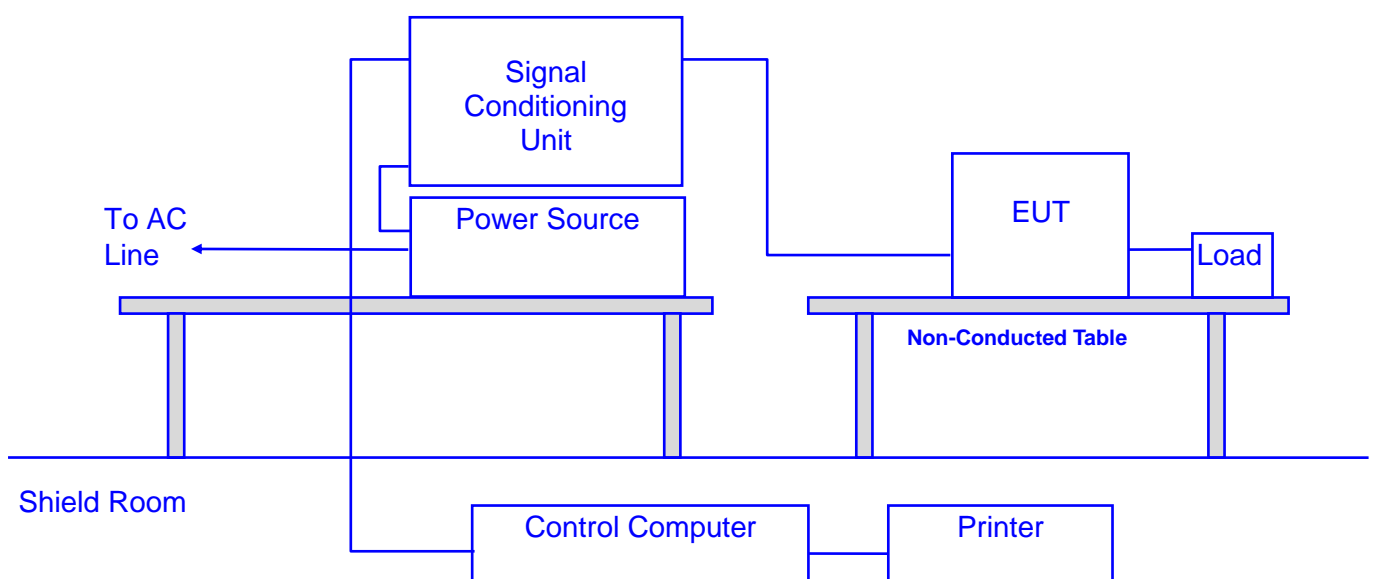

6.4 LIMITS OF HARMONIC CURRENT EMISSIONS AND FLICKER MEASUREMENT

Power Line Harmonics:

Class A

Harmonics Order	Maximum Permissible Harmonic current Per watt (mA/W)	Maximum Permissible Harmonic current (in amperes)
3	3.4	2.30
5	1.9	1.14
7	1.0	0.77
9	0.5	0.40
11	0.35	0.33
13 ≤ n ≤ 39 (Odd harmonics only)	3.85/n	See limit of Class A

Note: Harmonic currents less than 0.6% of the input current measured under the Test conditions, or less than 5mA, whichever is greater, are disregarded.

Flicker:

Limits	
P _{st}	1.0
P _{lt}	0.65
d(t)	3.3%
Time(ms)>dt	500ms
d _c	3.3%
d _{max}	4%

6.5 OPERATING CONDITIONS OF THE EUT

1. Setup the EUT and Test Equipment as shown on 6.3.
2. Power on the EUT. Acting performance checking program to allow EUT executing its usual operation mode during test.

6.6 TEST PROCEDURE

6.6.1 Flicker:

The test voltage supplied the EUT shall be maintained within 230V±2%.

The frequency shall be 50Hz±0.5%.

The observation period Tp:

-for P_{st} Tp=10min.

-for P_{lt} Tp=2h.

6.7 TEST RESULT

1. The measurement of the flicker, which test at the extremes of EUT's supply range was investigated, and the test result are reported the following data pages. The measurement limits were met, and the EUT passed the test.
2. The Flicker measurement uncertainty is 2 %.

Current Test Result Summary (Run time)

Date : 2026/01/15 AM 09:56:58

Operator **Ghost Chang**
 Unit **PCIe Pi HAT SSD**
 Serial Number **PT25R-Pi HAT SSD**

Remarks **The test point is at the AC power input terminal of the computer.**
 Test by Global EMC Standard Tech. Corp..

Test Result: **Pass** Source qualification: **Normal**
 THC(A): **0.081** I-THD(%): **33.6** POHC(A): **0.013** POHC Limit(A): **0.251**

Highest parameter values during test:

V_RMS (Volts): **230.013** Frequency(Hz): **50.00**
 I_Peak (Amps): **0.781** I_RMS (Amps): **0.351**
 I_Fund (Amps): **0.242** Crest Factor: **2.964**
 Power (Watts): **47.5** Power Factor: **0.843**

Harm#	Harms(avg)	100%Limit	%of Limit	Harms(max)	150%Limit	%of Limit	Status
2	0.002	1.080	N/A	0.004	1.620	N/A	Pass
3	0.072	2.300	3.1	0.082	3.450	2.4	Pass
4	0.002	0.430	N/A	0.003	0.645	N/A	Pass
5	0.018	1.140	1.6	0.024	1.710	1.4	Pass
6	0.001	0.300	N/A	0.002	0.450	N/A	Pass
7	0.020	0.770	2.6	0.021	1.155	1.8	Pass
8	0.001	0.230	N/A	0.002	0.345	N/A	Pass
9	0.011	0.400	2.9	0.014	0.600	2.3	Pass
10	0.001	0.184	N/A	0.002	0.276	N/A	Pass
11	0.010	0.330	3.0	0.012	0.495	2.3	Pass
12	0.001	0.153	N/A	0.002	0.230	N/A	Pass
13	0.009	0.210	4.5	0.011	0.315	3.4	Pass
14	0.002	0.131	N/A	0.003	0.197	N/A	Pass
15	0.007	0.150	4.8	0.008	0.225	3.7	Pass
16	0.002	0.115	N/A	0.002	0.173	N/A	Pass
17	0.008	0.132	6.3	0.010	0.198	4.9	Pass
18	0.002	0.102	N/A	0.002	0.153	N/A	Pass
19	0.006	0.118	5.4	0.007	0.178	4.1	Pass
20	0.002	0.092	N/A	0.002	0.138	N/A	Pass
21	0.005	0.107	4.7	0.006	0.161	3.7	Pass
22	0.002	0.084	N/A	0.002	0.125	N/A	Pass
23	0.005	0.098	N/A	0.006	0.147	N/A	Pass
24	0.002	0.077	N/A	0.002	0.115	N/A	Pass
25	0.005	0.090	N/A	0.005	0.135	N/A	Pass
26	0.001	0.071	N/A	0.002	0.107	N/A	Pass
27	0.005	0.083	6.0	0.006	0.125	4.7	Pass
28	0.001	0.066	N/A	0.002	0.099	N/A	Pass
29	0.004	0.078	N/A	0.006	0.116	N/A	Pass
30	0.001	0.061	N/A	0.002	0.092	N/A	Pass
31	0.004	0.073	N/A	0.005	0.109	N/A	Pass
32	0.001	0.058	N/A	0.002	0.086	N/A	Pass
33	0.003	0.068	N/A	0.004	0.102	N/A	Pass
34	0.001	0.054	N/A	0.002	0.081	N/A	Pass
35	0.004	0.064	N/A	0.004	0.096	N/A	Pass
36	0.001	0.051	N/A	0.002	0.077	N/A	Pass
37	0.003	0.061	N/A	0.004	0.091	N/A	Pass
38	0.001	0.048	N/A	0.001	0.073	N/A	Pass
39	0.003	0.058	N/A	0.004	0.087	N/A	Pass
40	0.001	0.046	N/A	0.001	0.069	N/A	Pass

Flicker Test Summary per EN/IEC61000-3-3 (Run time)

Date : 2026/01/15 AM 09:56:58

Operator Ghost Chang
 Unit PCIe Pi HAT SSD
 Serial Number PT25R-Pi HAT SSD

Remarks The test point is at the AC power input terminal of the computer.
 Test by Global EMC Standard Tech. Corp..

Pst_i and limit line

European Limits

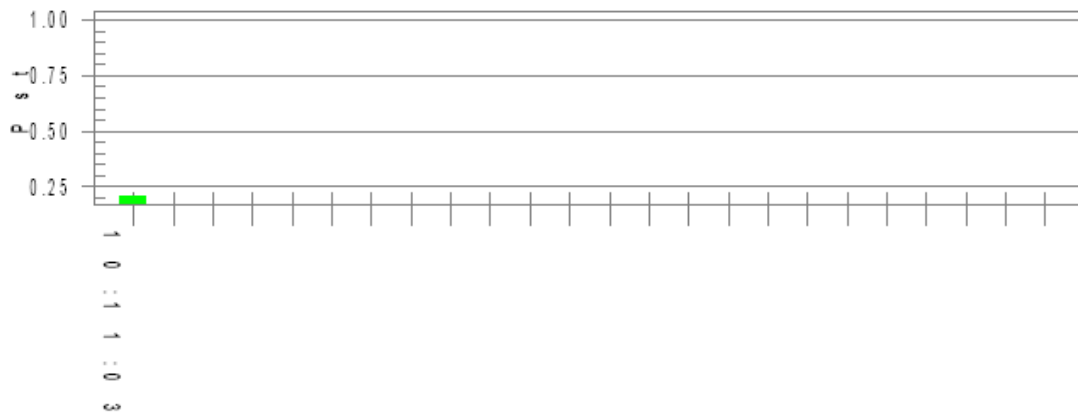

Plt and limit line

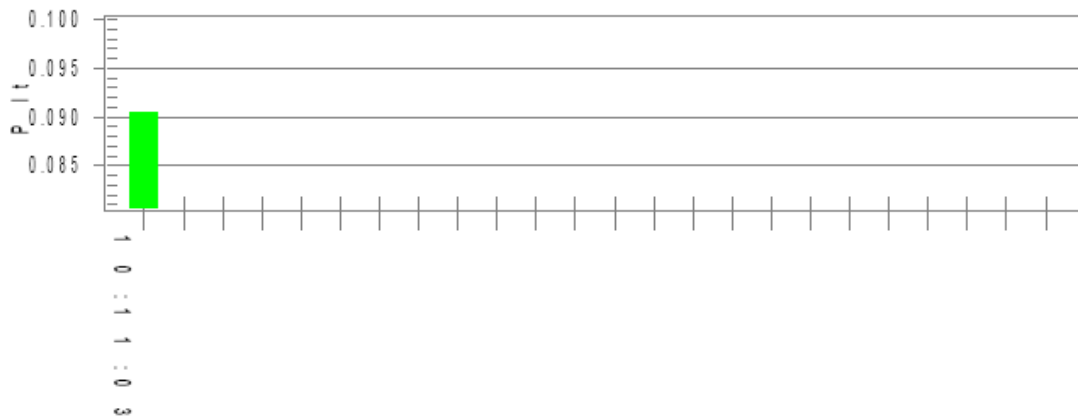

Parameter values recorded during the test:

Vrms at the end of test (Volt):	229.89		
T-max (mS):	0.0	Test limit (mS):	500.0 Pass
Highest dc (%):	0.00	Test limit (%):	3.30 Pass
Highest dmax (%):	-0.04	Test limit (%):	4.00 Pass
Highest Pst (10 min. period):	0.207	Test limit:	1.000 Pass

7. ESD IMMUNITY TEST

7.1 TEST EQUIPMENT

Item	Instrument	Manufacturer	Model	Serial No.	Next Cal. Date
1	ESD SIMULATOR SYSTEM	EM TEST	ESD 30C	V0611101245	2026.05.05

Note: 1. All equipments are calibrated and will be valid only for a period of 1 year.

2. The test was performed at GTK Shielded Room A3.

7.2 TEST METHOD

According to EN 55035:2017 + A11:2020

IEC 61000-4-2:2008

7.3 BLOCK DIAGRAM OF TEST SETUP

Note: This is a representative setup diagram for Table-top EUT.

For Floor-standing EUT, the table will be removed with all others setup condition remain the same.

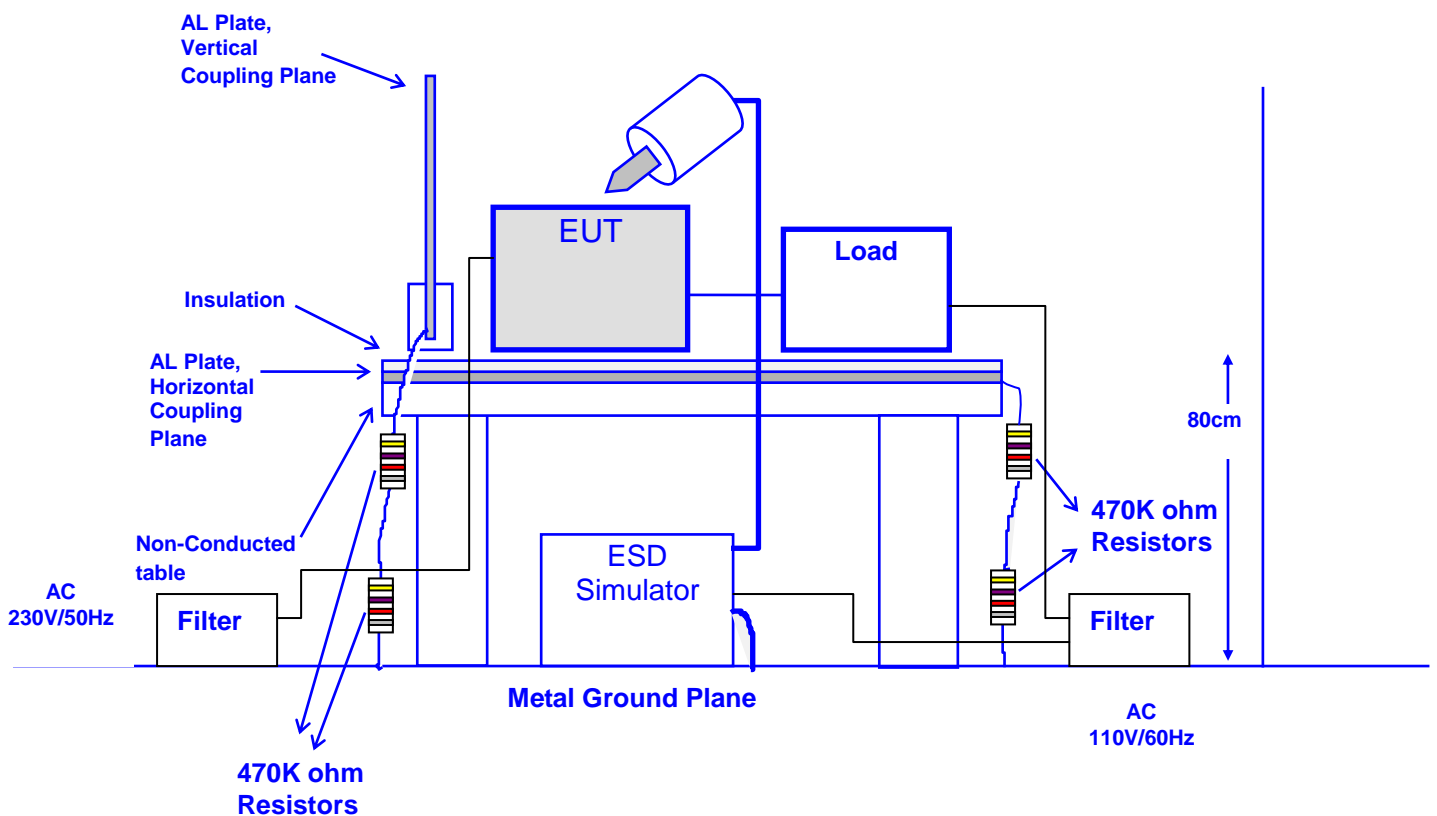

7.4 SEVERITY LEVELS

Contact discharge		Air discharge	
Level	Test voltage kV	Level	Test voltage kV
1	2	1	2
2	4	2	4
3	6	3	8
4	8	4	15
X	Special	X	Special

Required Performance Criteria : B
 Level : $\pm 8\text{kV}$ and lower levels (Air Discharge)
 $\pm 4\text{kV}$ and lower levels (Contact Discharge)

7.5 OPERATING CONDITIONS OF THE EUT

1. Setup the EUT and Test Equipment as shown on 7.3.
2. Power on the EUT. Acting performance checking program to allow EUT executing its usual operation mode during test.

7.6 TEST PROCEDURE

Air Discharge: discharge at slots and apertures and insulating surfaces:

This test was performed on non-conductive surfaces in accordance with IEC 61000-4-2.

The selected test point shall be subjected to at least 10 positive & 10 negative discharges with >1 second interval.

Contact Discharge: discharge to the conductive surfaces and coupling planes:

Each one test point shall be subjected to at least 10 positive & 10 negative discharges with >1 second interval.

Horizontal Coupling Plane (HCP) under the EUT & Vertical Coupling Plane (VCP) beside the 4 sides of the EUT, with the sharp discharge electrode touching the coupling plane.

HCP discharge:

ESD was applied to the earth reference plane on each accessible side of the EUT.

VCP discharge:

Vertical Coupling Plane was positioned at a distance of 0.1m from the EUT.

7.7 TEST RESULT

Date of Test	December 24, 2025	Temperature	20.2 °C
Test Mode	Mode 1	Humidity	51.7 %
Test Power Supply	DC 3.3V (by PC)	Atmospheric Pressure	998 hPa (mbar)

Item	Each Point of Discharge	Voltage	Required Criteria	Complied to Criteria (A, B, C)	Result
Air Discharge (Green arrow)	10	<input checked="" type="checkbox"/> +2kV <input checked="" type="checkbox"/> +4kV <input checked="" type="checkbox"/> +8kV	B	A	PASS
	10	<input checked="" type="checkbox"/> -2kV <input checked="" type="checkbox"/> -4kV <input checked="" type="checkbox"/> -8kV	B	A	PASS
Contact Discharge (Red arrow)	10	<input checked="" type="checkbox"/> +2kV <input checked="" type="checkbox"/> +4kV	B	A	PASS
	10	<input checked="" type="checkbox"/> -2kV <input checked="" type="checkbox"/> -4kV	B	A	PASS
Indirect Discharge (HCP)	10	<input checked="" type="checkbox"/> +2kV <input checked="" type="checkbox"/> +4kV	B	A	PASS
	10	<input checked="" type="checkbox"/> -2kV <input checked="" type="checkbox"/> -4kV	B	A	PASS
Indirect Discharge (VCP) (Front)	10	<input checked="" type="checkbox"/> +2kV <input checked="" type="checkbox"/> +4kV	B	A	PASS
	10	<input checked="" type="checkbox"/> -2kV <input checked="" type="checkbox"/> -4kV	B	A	PASS
Indirect Discharge (VCP) (Left)	10	<input checked="" type="checkbox"/> +2kV <input checked="" type="checkbox"/> +4kV	B	A	PASS
	10	<input checked="" type="checkbox"/> -2kV <input checked="" type="checkbox"/> -4kV	B	A	PASS
Indirect Discharge (VCP) (Back)	10	<input checked="" type="checkbox"/> +2kV <input checked="" type="checkbox"/> +4kV	B	A	PASS
	10	<input checked="" type="checkbox"/> -2kV <input checked="" type="checkbox"/> -4kV	B	A	PASS
Indirect Discharge (VCP) (Right)	10	<input checked="" type="checkbox"/> +2kV <input checked="" type="checkbox"/> +4kV	B	A	PASS
	10	<input checked="" type="checkbox"/> -2kV <input checked="" type="checkbox"/> -4kV	B	A	PASS

- Meet criteria A: Operate as intended during and after the test
- Meet criteria B: Operate as intended after the test
- Meet criteria C: Loss/Error of function
- Additional Information
 - There was no observable degradation in performance.
 - No false alarms or other malfunctions were observed during or after the test.

The acceptance criteria were met, and the EUT passed the test.

★ The green tag means the air discharge point (See the report page 53-54).

★ The red tag means the contact point (See the report page 53-54)

8. RF FIELD STRENGTH SUSCEPTIBILITY TEST

8.1 TEST EQUIPMENT

Item	Instrument	Manufacturer	Model	S/N or Version	Next Cal. Date
1	SIGNAL GENERATOR	RS	SMT03	838077/019	2026.03.05
2	Power Amplifier	AR	250W1000A	313023	N/A
3	BILOG ANTENNA	SCHAFFNER	CBL6112B	2935	N/A
4	Ultra Breitband Antenna	RS	ULTRALOG HL562	100282	N/A
5	Microwave Horn Antenna	AR	AT4510	308405	N/A
6	CHAMBER	GTK	N/A	A5	2026.12.19
7	Software	AR	SW1006	1.13	N/A
8	Radiated Immunity System	TESEQ	ITS 6006	77039	2026.01.21
9	Power Amplifier	TESEQ	CBA 3G-050	T44215	NCR
10	Power Amplifier	TESEQ	CBA 6G-050	1053053	NCR
11	Stacked Double Log.-Per. Antenna	Schwarzbeck	STLP 9128E	9128E084	NCR
12	Power Meter (1GHz-3GHz)	TESEQ	PM 6006	073363	2026.08.06
13	Power Meter (3GHz-6GHz)	TESEQ	PM 6006	073364	2026.08.06
14	Power Antenna	Schwarzbeck	STLP 9149	9149-185	NCR
15	Direction Coupler	WERLATONE	C6187-10	98619	2026.07.29
16	Direction Coupler	ATM	CHP-274-40F-40R	N482208-01	2026.07.29
17	Digital Thermo-Hygro Meter	iMAX	HTC-1	No. 2 RS Room	2026. 04. 08

Note: 1. All equipments are calibrated and will be valid only for a period of 1 year.

2. The test was performed at GTK Chamber A5 and Audix No.2 RS Room.

8.2 TEST METHOD

According to EN 55035:2017 + A11:2020

IEC 61000-4-3: 2020

8.3 BLOCK DIAGRAM OF TEST SETUP

Note: This is a representative setup diagram for Table-top EUT.
 For Floor-standing EUT, the table will be removed with all others setup condition remain the same.

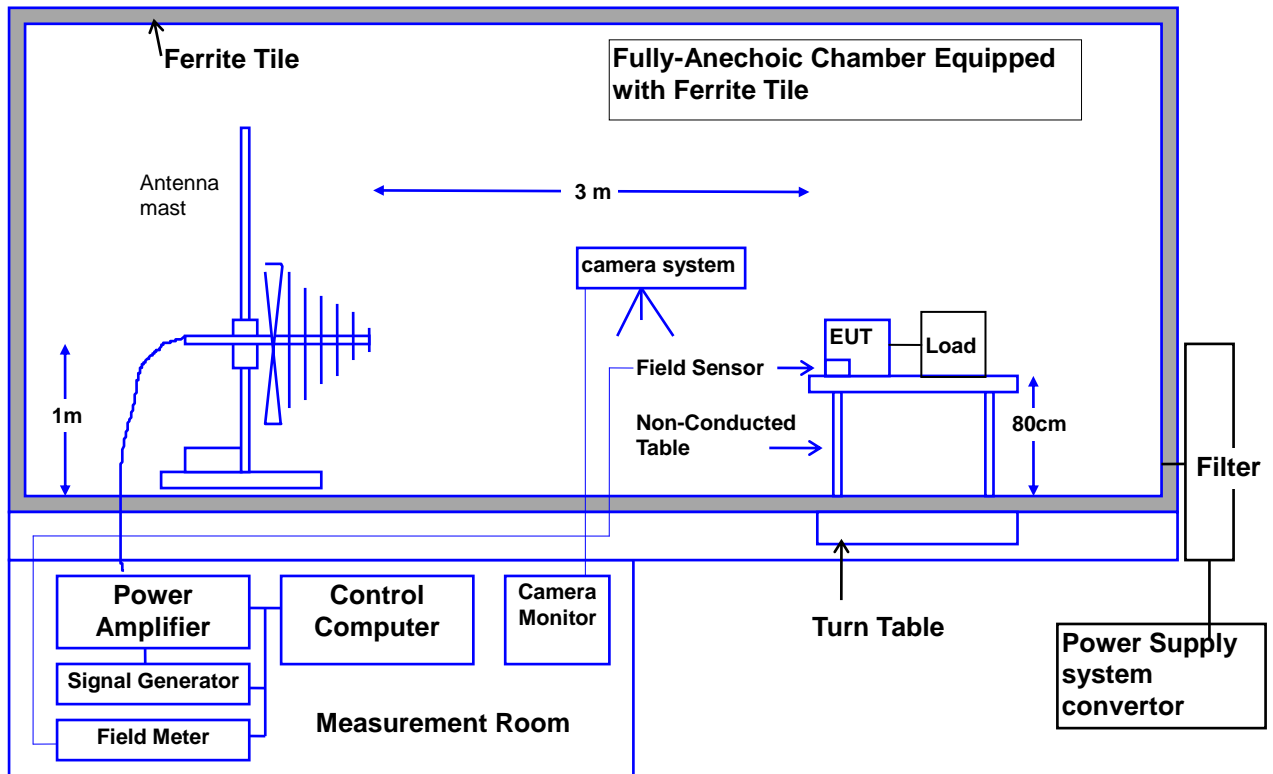

8.4 SEVERITY LEVELS

Required Performance Criteria : A
 Level : 80~1000, 1800, 2600, 3500, 5000MHz (1kHz
 sinewave with 80% Amplitude Modulation: 3V/m)

8.5 OPERATING CONDITIONS OF THE EUT

1. Setup the EUT and Test Equipment as shown on 8.3.
2. Power on the EUT. Acting performance checking program to allow EUT executing its usual operation mode during test.

8.6 TEST PROCEDURE

The EUT and load were placed on a table, which was 0.8 meters high. The field sensor was also placed on the same table to monitor field strength from transmitting antenna. EUT was set 3 meters away from the transmitting antenna. The transmitting antenna was fixed at 1 meter above ground. Both horizontal and vertical polarizations of the antenna were used during testing. In order to judge the EUT performance, a CCD camera was used to monitor the EUT screen.

All the scanning conditions are as follows:

Condition of Test	Remarks
Field Strength	3V/m
Radiated Signal	80-1000, 1800, 2600, 3500, 5000MHz (1kHz sinewave with 80% Amplitude modulation)
Dwell Time	3 Seconds
Frequency step size	1 % of the present frequency

8.7 TEST RESULT

Date of Test	December 23, 2025	Temperature	22.6 °C
Test Mode	Mode 1	Humidity	51.7 %
Test Power Supply	DC 3.3V (by PC)	Test by Global EMC Standard Tech. Corp..	

Freq. Range (MHz)	Position (Angle)	Polarity (H or V)	Field Strength (V/m)	Performance Criteria Complied to	Results
<input type="checkbox"/> 27-80 MHz	0	H / V	3	A	PASS
<input checked="" type="checkbox"/> 80-1000 MHz	90	H / V	3	A	PASS
<input type="checkbox"/> 900 ± 5 MHz	180	H / V	3	A	PASS
	270	H / V	3	A	PASS

- Meet criteria A: Operate as intended during and after the test
- Meet criteria B: Operate as intended after the test
- Meet criteria C: Loss/Error of function
- Additional Information
 - There was no observable degradation in performance.
 - No false alarms or other malfunctions were observed during or after the test. The acceptance criteria were met, and the EUT passed the test.

Date of Test	December 30, 2025	Temperature	22.0 °C
Test Mode	Mode 1	Humidity	49.0 %
Test Power Supply	DC 3.3V (by PC)	Test by Audix Technology Corporation.	

Freq. Range (MHz)	Position (Angle)	Polarity (H or V)	Field Strength (V/m)	Performance Criteria Complied to	Results
<input checked="" type="checkbox"/> 1800MHz	0	H / V	3	A	PASS
<input checked="" type="checkbox"/> 2600MHz	90	H / V	3	A	PASS
<input checked="" type="checkbox"/> 3500MHz	180	H / V	3	A	PASS
<input checked="" type="checkbox"/> 5000MHz	270	H / V	3	A	PASS

- Meet criteria A: Operate as intended during and after the test
- Meet criteria B: Operate as intended after the test
- Meet criteria C: Loss/Error of function
- Additional Information
 - There was no observable degradation in performance.
 - No false alarms or other malfunctions were observed during or after the test. The acceptance criteria were met, and the EUT passed the test.

9. ELECTRICAL FAST TRANSIENT/BURST IMMUNITY TEST

9.1 TEST EQUIPMENT

Item	Instrument	Manufacturer	Model	S/N or Version	Next Cal. Date
1	Ultra Compact Simulator	EM TEST	UCS 500N5.1	P1310114655	2026.04.22
2	Software	EM TEST	ISMIEC	5.3.0	N/A

Note: 1. All equipments are calibrated and will be valid only for a period of 1 year.

2. The test was performed at GTK Shielded Room A4.

9.2 TEST METHOD

According to EN 55035:2017 + A11:2020

IEC 61000-4-4:2012

9.3 BLOCK DIAGRAM OF TEST SETUP

Note: This is a representative setup diagram for Table-top EUT.

For Floor-standing EUT, the table will be removed with all others setup condition remain the same.

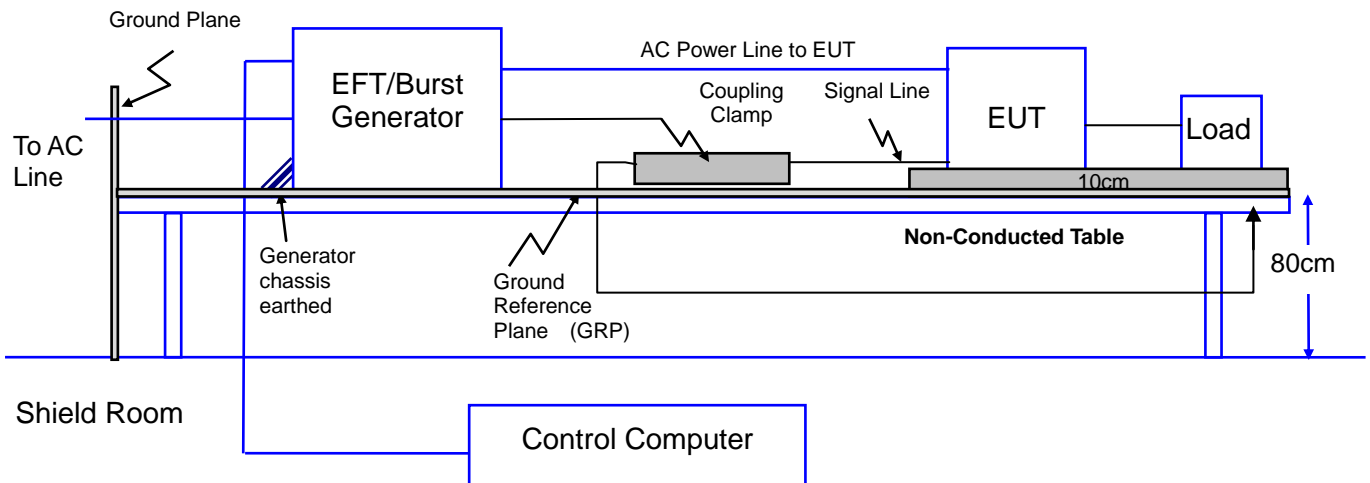

9.4 SEVERITY LEVELS

Required Performance Criteria : B
 Level : ±0.5kV, ±1.0kV for Power Lines

9.5 OPERATING CONDITIONS OF THE EUT

1. Setup the EUT and Test Equipment as shown on 9.3.
2. Power on the EUT. Acting performance checking program to allow EUT executing its usual operation mode during test.

The EUT and its load were placed on a table which was 0.8 meters above a metal ground plane measuring 2m by 2m and 0.65mm thick min, and projecting beyond the EUT by at least 0.1m on all sides. More than 0.5 meters separated the EUT from the walls of the shielded room.

Prior to the start of the test, a functional test was performed on the EUT to ensure proper operation. The EUT was also monitored during the test for any degradation of performance.

For AC Power lines test:

The EUT is connected to the power mains through a coupling/decoupling network that directly injected the transient energy. Bursts of pulse trains were injected onto the power line, in both positive and negative polarities. The test level was 0.5kV & 1.0kV. The Line, Neutral, and protective earth conductors were impressed with burst noise for one minute.

9.6 TEST RESULT

Date of Test	December 24, 2025	Temperature	22.5 °C
Test Mode	Mode 1	Humidity	50.9 %
Test Power Supply	The test point is at the AC power input terminal of the computer.		

Inject Place: Power Supply Line							
Inject Line	Polarity	Voltage kV	Inject time (minute)	Inject Method	Required Criteria	Complied to Criteria	Result
L+N+PE	+	<input checked="" type="checkbox"/> 0.5	1	DIRECT	B	A	PASS
		<input checked="" type="checkbox"/> 1.0	1	DIRECT	B	A	PASS
L+N+PE	-	<input checked="" type="checkbox"/> 0.5	1	DIRECT	B	A	PASS
		<input checked="" type="checkbox"/> 1.0	1	DIRECT	B	A	PASS

- Meet criteria A: Operate as intended during and after the test
- Meet criteria B: Operate as intended after the test
- Meet criteria C: Loss/Error of function
- Additional Information
 - There was no observable degradation in performance.
 - No false alarms or other malfunctions were observed during or after the test. The acceptance criteria were met, and the EUT passed the test.

10. SURGE IMMUNITY TEST

10.1 TEST EQUIPMENT

Item	Instrument	Manufacturer	Model	S/N or Version	Next Cal. Date
1	Ultra Compact Simulator	EM TEST	UCS 500N5.1	P1310114655	2026.04.22
2	Software	EM TEST	ISMIEC	5.3.0	N/A

Note: 1. All equipments are calibrated and will be valid only for a period of 1 year.

2. The test was performed at GTK Shielded Room A4.

10.2 TEST METHOD

According to EN 55035:2017 + A11:2020

IEC 61000-4-5: 2014+A1: 2017

10.3 BLOCK DIAGRAM OF TEST SETUP

Note: This is a representative setup diagram for Table-top EUT.

For Floor-standing EUT, the table will be removed with all others setup condition remain the same.

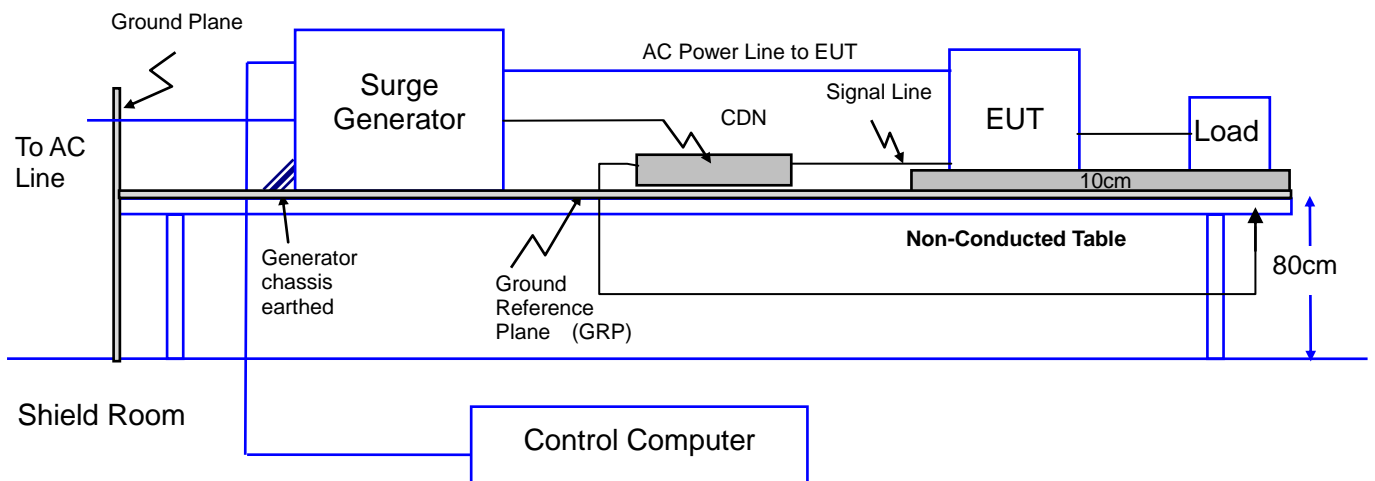

10.4 SEVERITY LEVELS

Open Circuit Output Test Voltage +/- 10%	
Level	On power supply lines
1	0.5kV
2	1kV
3	2kV
4	4kV
X	Special

10.5 OPERATING CONDITIONS OF THE EUT

1. Setup the EUT and Test Equipment as shown on 10.3.
2. Power on the EUT. Acting performance checking program to allow EUT executing its usual operation mode during test.

10.6 TEST PROCEDURE

A "combination wave" as specified in IEC 61000-4-5 was applied to the EUT. The amplitude was gradually increased using control software. Surges were initiated line synced. The surges were applied at a rate of 1 surge per minute. The EUT was monitored for any degradation of performance. The AC test was conducted for differential mode at 0.5kV & 1.0kV and common mode at 0.5kV & 1.0kV & 2.0kV. All tests were run in both the positive and negative polarity for differential and common modes.

The number of pulses applied shall be as follows:

- Five positive pulses line-to-neutral at 90° phase
- Five negative pulses line-to-neutral at 270° phase

The following additional pulses are required only if the EUT has an earth connection or if the EUT is earthed via any AE.

- Five positive pulses line-to-earth at 90° phase
- Five negative pulses line-to-earth at 270° phase
- Five positive pulses neutral-to-earth at 270° phase
- Five negative pulses neutral-to-earth at 90° phase

10.7 TEST RESULT

Date of Test	December 24, 2025	Temperature	22.1 °C
Test Mode	Mode 1	Humidity	51.3 %
Test Power Supply	The test point is at the AC power input terminal of the computer.		

AC Power line test								
Inject Line	Voltage kV	Repetition Rate (minute)	Phase Angle	Surge applied Method	Number of pulse	Required Criteria	Complied to Criteria	Result
L-N (Differential mode)	<input checked="" type="checkbox"/> +0.5 <input checked="" type="checkbox"/> +1.0	1	90°	CDN	5	B	A	PASS
	<input checked="" type="checkbox"/> -0.5 <input checked="" type="checkbox"/> -1.0	1	270°	CDN	5	B	A	PASS
L-PE (Common mode)	<input checked="" type="checkbox"/> +0.5 <input checked="" type="checkbox"/> +1.0 <input checked="" type="checkbox"/> +2.0	1	90°	CDN	5	B	A	PASS
	<input checked="" type="checkbox"/> -0.5 <input checked="" type="checkbox"/> -1.0 <input checked="" type="checkbox"/> -2.0	1	270°	CDN	5	B	A	PASS
	<input checked="" type="checkbox"/> +0.5 <input checked="" type="checkbox"/> +1.0 <input checked="" type="checkbox"/> +2.0	1	270°	CDN	5	B	A	PASS
N-PE (Common mode)	<input checked="" type="checkbox"/> -0.5 <input checked="" type="checkbox"/> -1.0 <input checked="" type="checkbox"/> -2.0	1	90°	CDN	5	B	A	PASS
	<input checked="" type="checkbox"/> +0.5 <input checked="" type="checkbox"/> +1.0 <input checked="" type="checkbox"/> +2.0	1	270°	CDN	5	B	A	PASS
	<input checked="" type="checkbox"/> -0.5 <input checked="" type="checkbox"/> -1.0 <input checked="" type="checkbox"/> -2.0	1	90°	CDN	5	B	A	PASS

- Meet criteria A: Operate as intended during and after the test
- Meet criteria B: Operate as intended after the test
- Meet criteria C: Loss/Error of function
- Additional Information
 - There was no observable degradation in performance.
 - No false alarms or other malfunctions were observed during or after the test. The acceptance criteria were met, and the EUT passed the test.

11. CONDUCTED DISTURBANCE SUSCEPTIBILITY TEST

11.1 TEST EQUIPMENT

Item	Instrument	Manufacturer	Model	S/N or Version	Next Cal. Date
1	Continuous Wave Simulator	EM TEST	CWS 500 A	1099-01	2026.03.04
2	Dual Directional Couplor	AR	DC-2600	20193	N/A
3	VOLTMETER	BOONTON	9200C	361501AA	2026.12.11
4	ATTENUATOR	BNOS	AT50-6-250	521926	N/A
5	CDN(EUT)	LUTHI	CDN L-801 M2/M3	2627	2026.07.08
6	CDN (AE)	Knorr Bremse	M3	12184	N/A
7	SHIELDING ROOM	GTK	N/A	A4	2026.05.20
8	Software	EM TEST	ICD	2.20	N/A

Note: 1. All equipments are calibrated and will be valid only for a period of 1 year.

2. The test was performed at GTK Shielded Room A4.

11.2 TEST METHOD

According to EN 55035:2017 + A11:2020
 IEC 61000-4-6:2023

11.3 BLOCK DIAGRAM OF TEST SETUP

Note: This is a representative setup diagram for Table-top EUT.

For Floor-standing EUT, the table will be removed with all others setup condition remain the same.

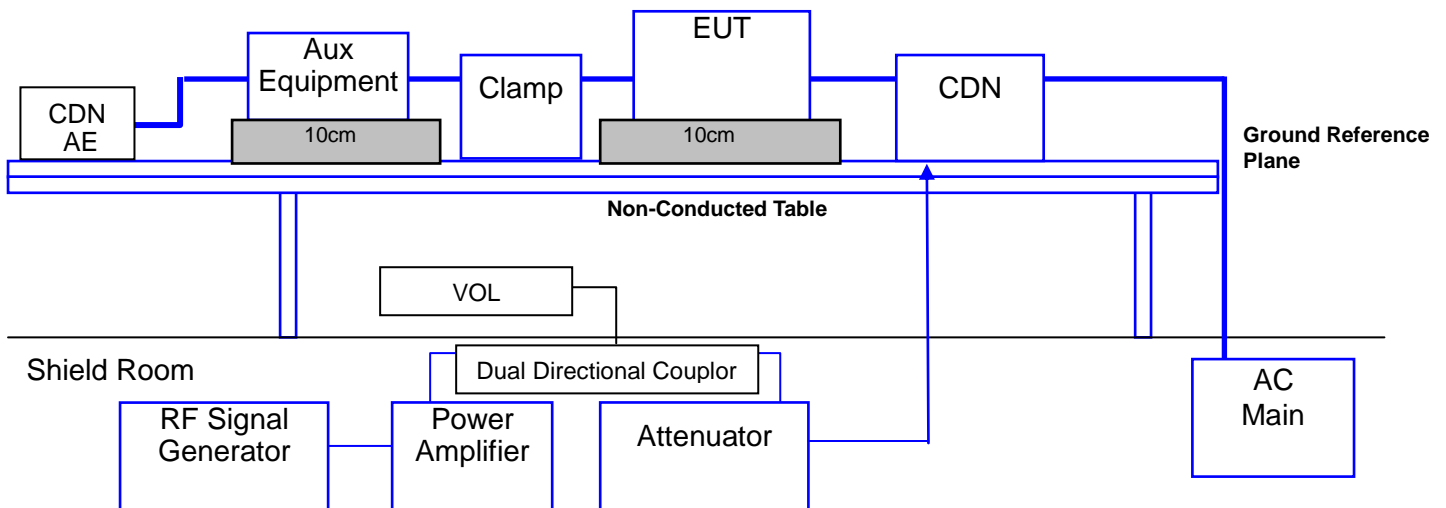

11.4 SEVERITY LEVELS

Test specification	
Required Performance Criteria	: A
Level	: 1kHz sine wave with 80% Amplitude Modulation: 3V
Frequency range	: 0.15-10MHz
Level	: 1kHz sine wave with 80% Amplitude Modulation: 3V~1V
Frequency range	: 10-30MHz
Level	: 1kHz sine wave with 80% Amplitude Modulation: 1V
Frequency range	: 30-80MHz

11.5 OPERATING CONDITIONS OF THE EUT

1. Setup the EUT and Test Equipment as shown on 11.3.
2. Power on the EUT. Acting performance checking program to allow EUT executing its usual operation mode during test.

11.6 TEST PROCEDURE

The EUT and load were placed on a table, which was 0.1 meters high from a Ground reference plane. Prior to the start of the test, a functional test was performed on the EUT to ensure proper operation. The EUT was also monitored during the test for any degradation of performance. Also, prior to the start of the test, clamp injection (RF current probe) calibration measurements were performed as described in IEC 61000-4-6: 2023.

For AC Power line test & For Signal Lines and Control Lines test:

The disturbance signal is through a coupling and decoupling networks (CDN) or EM-clamp device couples to the signal and control lines of the EUT.

After completion of the test, a functional test was performed on the EUT to ensure proper operation.

All the scanning conditions are as follows:

Condition of Test	Remarks
Field Strength	3V 3~1V 1V
Radiated Signal	0.15-10MHz (1kHz sinewave with 80% Amplitude modulation) 10-30MHz (1kHz sinewave with 80% Amplitude modulation) 30-80MHz (1kHz sinewave with 80% Amplitude modulation)
Dwell Time	3 Seconds
Frequency step size	1% of the present frequency

11.7 TEST RESULT

Date of Test	December 24, 2025	Temperature	21.4 °C
Test Mode	Mode 1	Humidity	51.8 %
Test Power Supply	The test point is at the AC power input terminal of the computer.		

Frequency Range (MHz)	Inject Line	Field Strength	Inject Method	Required Criteria	Performance Criteria Complied To	Result
0.15~10	AC Line	3V	CDN	A	A	PASS
10~30	AC Line	3~1V	CDN	A	A	PASS
30~80	AC Line	1V	CDN	A	A	PASS

- Meet criteria A: Operate as intended during and after the test
- Meet criteria B: Operate as intended after the test
- Meet criteria C: Loss/Error of function
- Additional Information
 - There was no observable degradation in performance.
 - No false alarms or other malfunctions were observed during or after the test. The acceptance criteria were met, and the EUT passed the test.

12. MAGNETIC FIELD IMMUNITY MEASUREMENT

12.1 TEST EQUIPMENT

Item	Instrument	Manufacturer	Model	S/N or Version	Next Cal. Date
1	Ultra Compact Simulator	EM TEST	UCS 500N5.1	P1310114655	2026.04.22
2	MAGNETIC FIELD ANTENNA	EM TEST	MS100	D3730	2026.04.22
3	Software	EM TEST	ISMIEC	5.3.0	N/A

Note: 1. All equipments are calibrated and will be valid only for a period of 1 year.

2. The test was performed at GTK Shielded Room A4.

12.2 TEST METHOD

According to EN 55035:2017 + A11:2020

IEC 61000-4-8:2009

12.3 BLOCK DIAGRAM OF TEST SETUP

Note: This is a representative setup diagram for Table-top EUT.

For Floor-standing EUT, the table will be removed with all others setup condition remain the same.

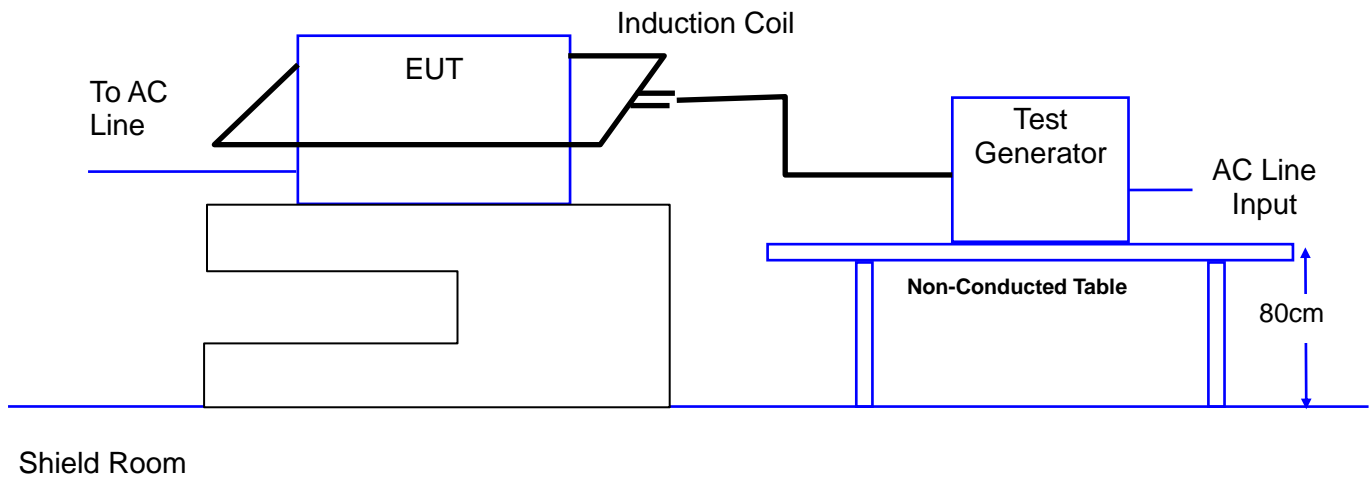

12.4 SEVERITY LEVELS

Test level for continuous field		Test levels for short duration: 1to3s	
Level	Magnetic Field Strength A/m	Level	Magnetic Field Strength A/m
1	1	1	n.a.
2	3	2	n.a.
3	10	3	n.a.
4	30	4	300
5	100	5	1000
X	Special	X	Special
"X" is an open level.		"X" is an open level. n.a.= not application	
Test level	Required Performance Criteria	Test Duration	
1	A	Continued Field	

12.5 EUT OPERATION CONDITION

1. Setup the EUT and Test Equipment as shown on 12.3.
2. Power on. Active performance checking program to allow EUT execute its usual operation mode during test.

12.6 TEST PROCEDURE

The EUT and its load are placed on a table which is 0.8 meter above a metal ground plane measured at least 1m*1m min. The test magnetic Field shall be applied by the immersion method to the EUT, previously set-up as specified in 12.3. And 90 shall rotate the induction coil° in order to expose the EUT to the test field with different orientation.

12.7 TEST RESULT

Date of Test	December 24, 2025	Temperature	21.7 °C
Test Mode	Mode 1	Humidity	51.6 %
Test Power Supply	DC 3.3V (by PC)		

Induction Coil Orientation	Testing Duration	Magnetic Field Strength A/m	Performance Criteria Complied To	Test Result
X	60 sec.	1 A/m, 50Hz	A	PASS
Y	60 sec.	1 A/m, 50Hz	A	PASS
Z	60 sec.	1 A/m, 50Hz	A	PASS

- Meet criteria A: Operate as intended during and after the test
 - Meet criteria B: Operate as intended after the test
 - Meet criteria C: Loss/Error of function
 - Additional Information
 - There was no observable degradation in performance.
 - No false alarms or other malfunctions were observed during or after the test.
- The acceptance criteria were met, and the EUT passed the test.

Date of Test	December 24, 2025	Temperature	21.7 °C
Test Mode	Mode 1	Humidity	51.6 %
Test Power Supply	DC 3.3V (by PC)		

Induction Coil Orientation	Testing Duration	Magnetic Field Strength A/m	Performance Criteria Complied To	Test Result
X	60 sec.	1 A/m, 60Hz	A	PASS
Y	60 sec.	1 A/m, 60Hz	A	PASS
Z	60 sec.	1 A/m, 60Hz	A	PASS

- Meet criteria A: Operate as intended during and after the test
 - Meet criteria B: Operate as intended after the test
 - Meet criteria C: Loss/Error of function
 - Additional Information
 - There was no observable degradation in performance.
 - No false alarms or other malfunctions were observed during or after the test.
- The acceptance criteria were met, and the EUT passed the test.

13. VOLTAGE DIPS AND SHORT INTERRUPTIONS TEST

13.1 TEST EQUIPMENT

Item	Instrument	Manufacturer	Model	S/N or Version	Next Cal. Date
1	Ultra Compact Simulator	EM TEST	UCS 500N5.1	P1310114655	2026.04.22

Note: 1. All equipments are calibrated and will be valid only for a period of 1 year.

2. The test was performed at GTK Shielded Room A4.

13.2 TEST METHOD

According to EN 55035:2017 + A11:2020

IEC 61000-4-11:2020 +COR1:2020 +COR2:2022

13.3 BLOCK DIAGRAM OF TEST SETUP

Note: This is a representative setup diagram for Table-top EUT.

For Floor-standing EUT, the table will be removed with all others setup condition remain the same.

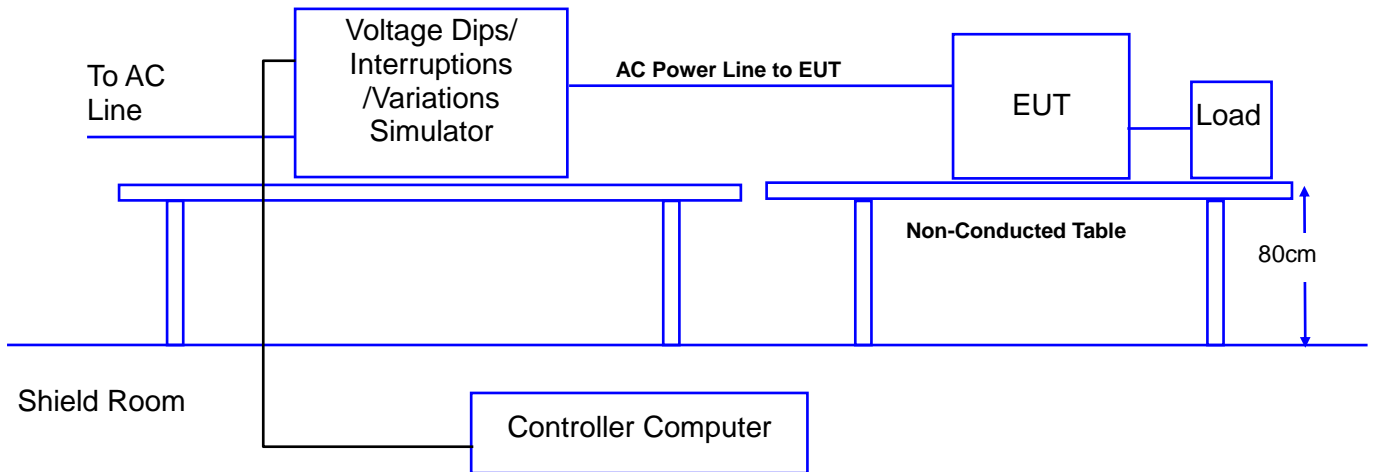

13.4 SEVERITY LEVELS

For 50Hz

Voltage Dips and Interruption Reduction(%)	Test Duration	Required Performance Criteria
>95	10 ms	B
30	500 ms	C
>95	5s	C

For 60Hz

Voltage Dips and Interruption Reduction(%)	Test Duration	Required Performance Criteria
>95	8.33 ms	B
30	500 ms	C
>95	5s	C

13.5 OPERATING CONDITIONS OF THE EUT

1. Setup the EUT and Test Equipment as shown on 13.3.
2. Power on the EUT. Acting performance checking program to allow EUT executing its usual operation mode during test.

13.6 TEST PROCEDURE

The EUT and its load were placed on a table which was 0.8 meters height.

For AC Power line test (For 50Hz):

The EUT was connected to the power mains through a coupling device that directly couples to the Voltage Dips and Interruption Generator.

Voltage dips of >95% for 10ms and 30% for 500ms were applied to the EUT three times with 10 sec intervals between dips. A power interruption of >95% for 5000ms (5 sec) was applied to the EUT three times with 60-second intervals between interruptions.

For AC Power line test (For 60Hz):

The EUT was connected to the power mains through a coupling device that directly couples to the Voltage Dips and Interruption Generator.

Voltage dips of >95% for 8.33ms and 30% for 500ms were applied to the EUT three times with 10 sec intervals between dips. A power interruption of >95% for 5000ms (5 sec) was applied to the EUT three times with 60-second intervals between interruptions.

13.7 TEST RESULT

Date of Test	December 24, 2025	Temperature	21.7 °C
Test Mode	Mode 1	Humidity	51.3 %
Test Power Supply	The test point is at the AC power input terminal of the computer. 100V/50Hz		

Item	Phase Angle	Reduction (%)	Test Duration (ms)	Required Criteria	Complied to Criteria	Result
Voltage Short Interruptions	<input checked="" type="checkbox"/> 0	>95	5000	C	B	PASS
	<input checked="" type="checkbox"/> 0	>95	10	B	A	PASS
Voltage Dips	<input checked="" type="checkbox"/> 0	30	500	C	A	PASS

- Meet criteria A: Operate as intended during and after the test
- Meet criteria B: Operate as intended after the test
- Meet criteria C: Loss of function, provided the function is self-recoverable, or can be restored by the operation of the controls
- Additional Information
 - There was no observable degradation in performance.
 - No false alarms or other malfunctions were observed during or after the test. The acceptance criteria were met, and the EUT passed the test.

Date of Test	December 24, 2025	Temperature	21.7 °C
Test Mode	Mode 1	Humidity	51.3 %
Test Power Supply	The test point is at the AC power input terminal of the computer. 100V/60Hz		

Item	Phase Angle	Reduction (%)	Test Duration (ms)	Required Criteria	Complied to Criteria	Result
Voltage Short Interruptions	<input checked="" type="checkbox"/> 0	>95	5000	C	B	PASS
	<input checked="" type="checkbox"/> 0	>95	8.33	B	A	PASS
Voltage Dips	<input checked="" type="checkbox"/> 0	30	500	C	A	PASS

- Meet criteria A: Operate as intended during and after the test
- Meet criteria B: Operate as intended after the test
- Meet criteria C: Loss of function, provided the function is self-recoverable, or can be restored by the operation of the controls
- Additional Information
 - There was no observable degradation in performance.
 - No false alarms or other malfunctions were observed during or after the test. The acceptance criteria were met, and the EUT passed the test.

Date of Test	December 24, 2025	Temperature	21.7 °C
Test Mode	Mode 1	Humidity	51.3 %
Test Power Supply	The test point is at the AC power input terminal of the computer. 240V/50Hz		

Item	Phase Angle	Reduction (%)	Test Duration (ms)	Required Criteria	Complied to Criteria	Result
Voltage Short Interruptions	<input checked="" type="checkbox"/> 0	>95	5000	C	B	PASS
Voltage Dips	<input checked="" type="checkbox"/> 0	>95	10	B	A	PASS
	<input checked="" type="checkbox"/> 0	30	500	C	A	PASS

- Meet criteria A: Operate as intended during and after the test
- Meet criteria B: Operate as intended after the test
- Meet criteria C: Loss of function, provided the function is self-recoverable, or can be restored by the operation of the controls
- Additional Information
 - There was no observable degradation in performance.
 - No false alarms or other malfunctions were observed during or after the test. The acceptance criteria were met, and the EUT passed the test.

Date of Test	December 24, 2025	Temperature	21.7 °C
Test Mode	Mode 1	Humidity	51.3 %
Test Power Supply	The test point is at the AC power input terminal of the computer. 240V/60Hz		

Item	Phase Angle	Reduction (%)	Test Duration (ms)	Required Criteria	Complied to Criteria	Result
Voltage Short Interruptions	<input checked="" type="checkbox"/> 0	>95	5000	C	B	PASS
Voltage Dips	<input checked="" type="checkbox"/> 0	>95	8.33	B	A	PASS
	<input checked="" type="checkbox"/> 0	30	500	C	A	PASS

- Meet criteria A: Operate as intended during and after the test
- Meet criteria B: Operate as intended after the test
- Meet criteria C: Loss of function, provided the function is self-recoverable, or can be restored by the operation of the controls
- Additional Information
 - There was no observable degradation in performance.
 - No false alarms or other malfunctions were observed during or after the test. The acceptance criteria were met, and the EUT passed the test.

14. PHOTOGRAPHS FOR TEST

14.1 TEST PHOTOGRAPHS FOR CONDUCTION



14.2 TEST PHOTOGRAPHS FOR RADIATED (30 MHz to 1 GHz)

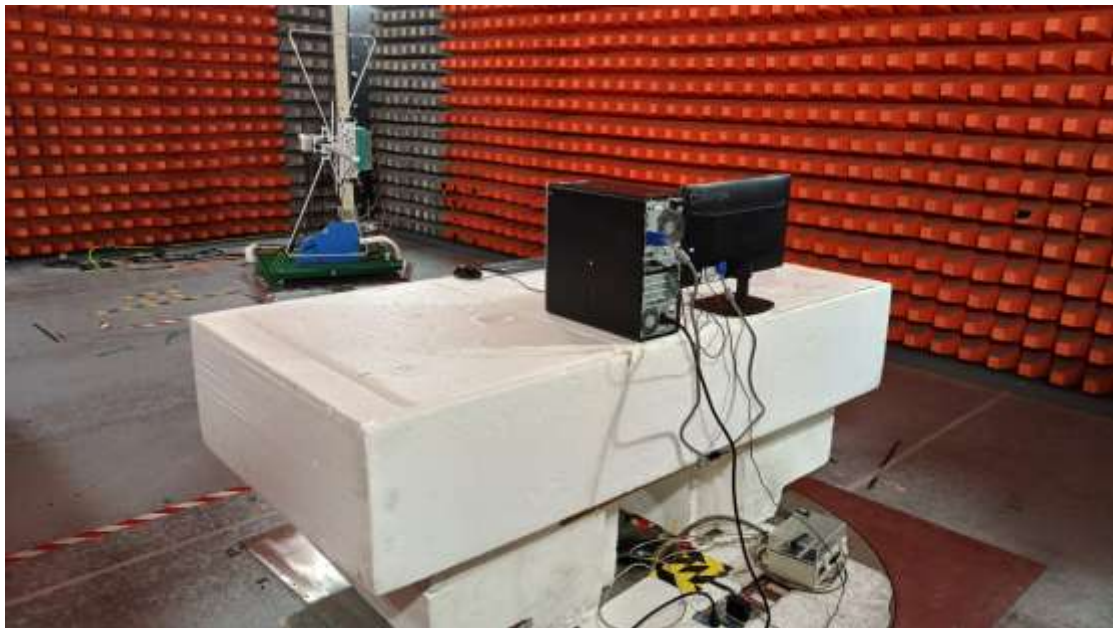

(Above 1 GHz)

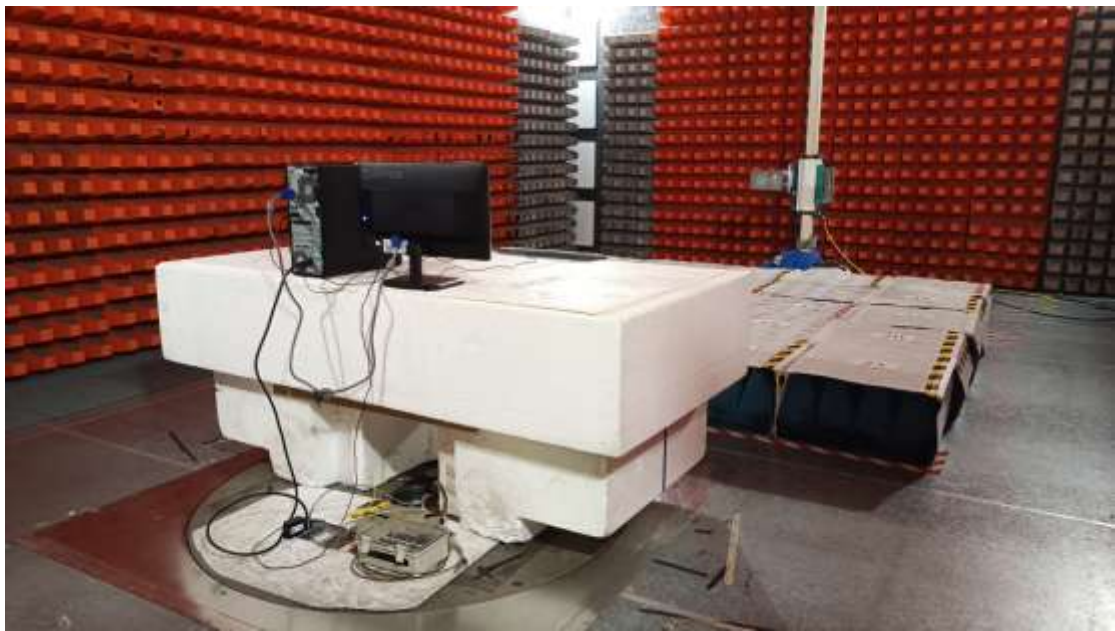

14.3 TEST PHOTOGRAPHS FOR HARMONIC/FLICKER Test by Global EMC Standard Tech. Corp..



14.4 TEST PHOTOGRAPHS FOR ESD



14.5 TEST PHOTOGRAPHS FOR ESD TEST POINTS





14.6 TEST PHOTOGRAPHS FOR RS

Test by Global EMC Standard Tech. Corp..

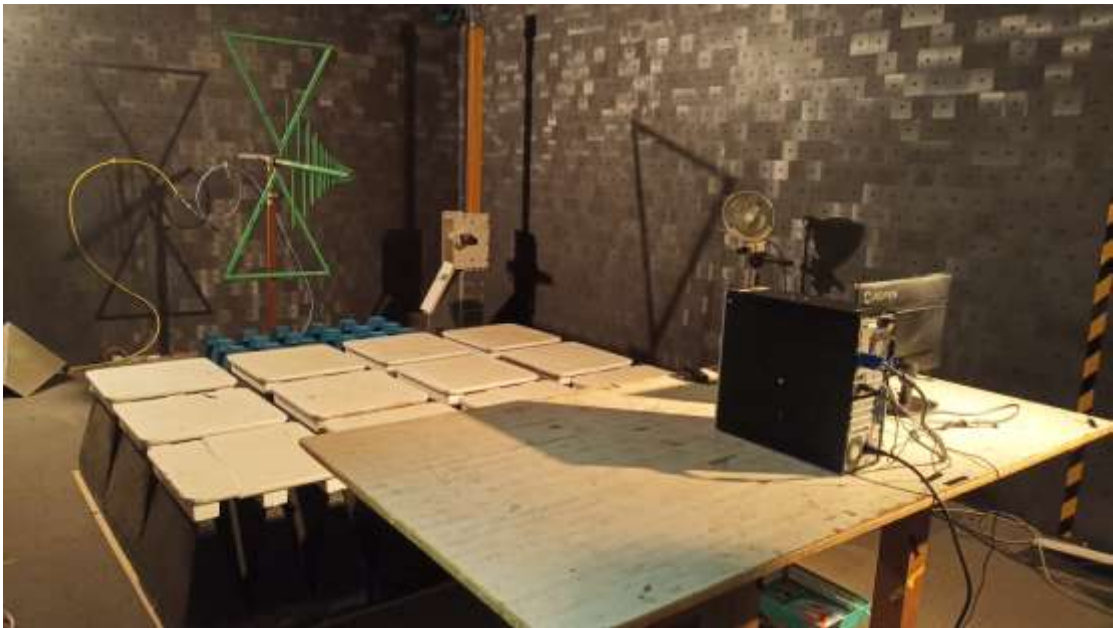

Test by Audix Technology Corporation.



14.7 TEST PHOTOGRAPHS FOR EFT



14.8 TEST PHOTOGRAPHS FOR SURGE



14.9 TEST PHOTOGRAPHS FOR CS



14.10 TEST PHOTOGRAPHS FOR MAGNETIC

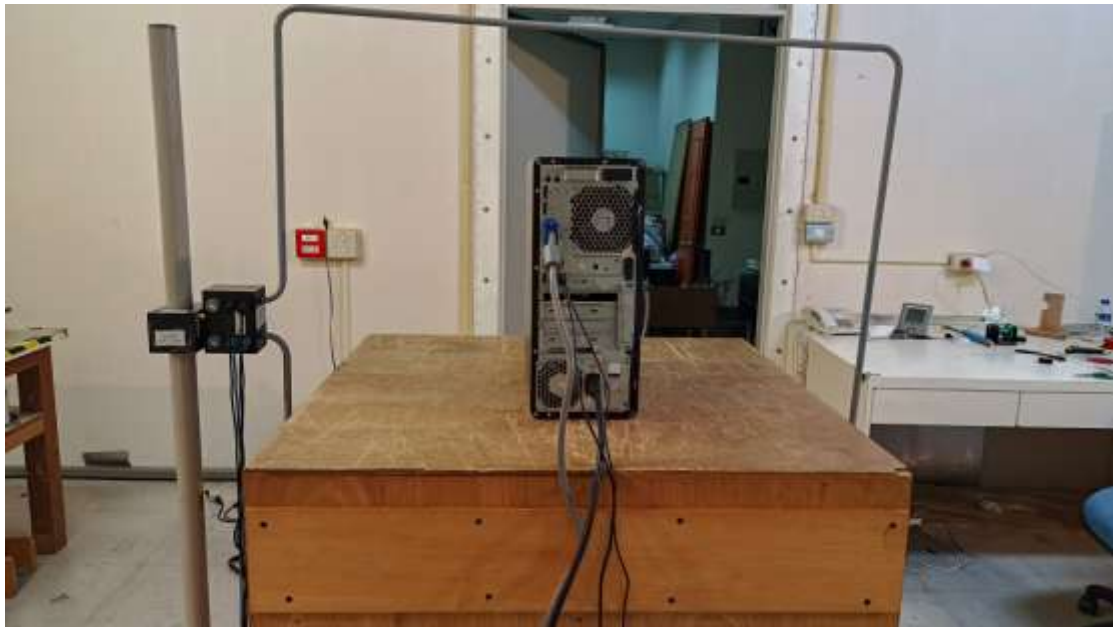
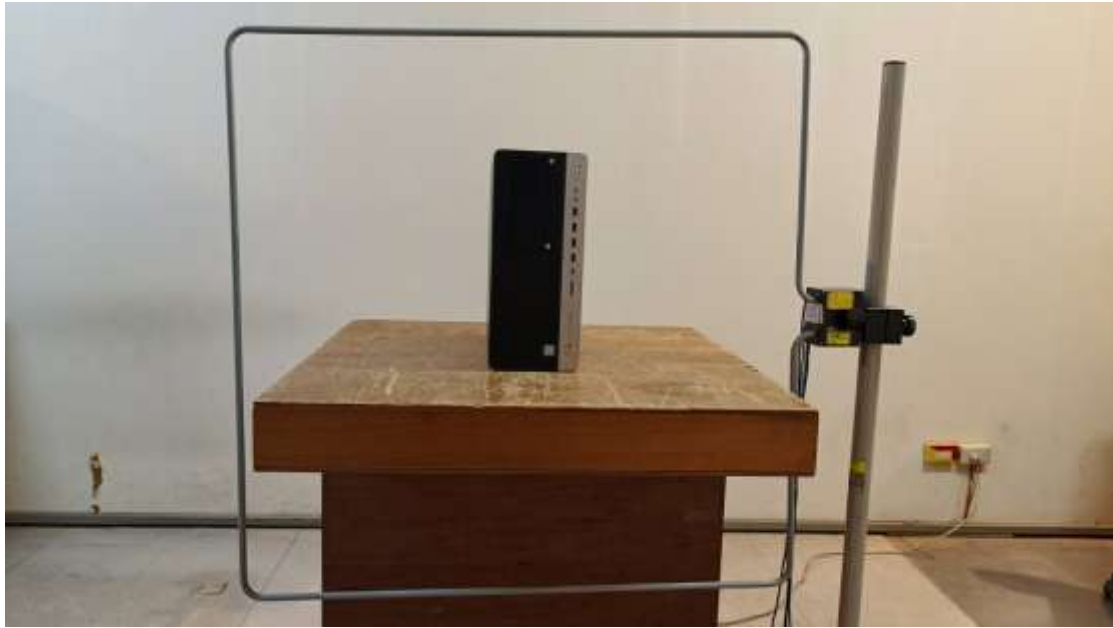

14.11 TEST PHOTOGRAPHS FOR DIPS



15. PHOTOGRAPHS FOR PRODUCT

1. Front View of PCIe Pi HAT SSD.
2. Back View of PCIe Pi HAT SSD.

