

# Certificate

Issue Date: September 23, 2019  
Ref. Report No. ISL-19LE512CE-MA

Product Name : PCIe CFexpress  
Model(s) : PV130-CFX  
Brand : Apacer  
Responsible Party : Apacer Technology Inc.  
Address : 1F., No.32, Zhongcheng Rd., Tucheng Dist., New Taipei City 236, Taiwan ,  
R.O.C.

We, **International Standards Laboratory Corp.**, hereby certify that:

The sample ISL received which bearing the trade name and model specified above has been shown to comply with the applicable technical standards as indicated in the measurement report and was tested in accordance with the measurement procedures specified in European Council Directive EMC Directive 2014/30/EU. And Our laboratories is the accredited laboratories and are approved according to ISO/IEC 17025. The device was passed the test performed according to :

## Standards:

EN 55032:2015+AC:2016, CISPR 32: 2015+COR1:2016: Class B  
AS/NZS CISPR 32:2015: Class B  
EN 61000-3-2:2014 and IEC 61000-3-2:2014  
EN 61000-3-3: 2013 and IEC 61000-3-3: 2013  
EN 55024: 2010+A1:2015 and CISPR 24: 2010+A1:2015  
EN 61000-4-2: 2009 and IEC 61000-4-2: 2008  
EN 61000-4-3: 2006+A1: 2008 +A2: 2010 and  
IEC 61000-4-3:2006+A1: 2007+A2: 2010  
EN 61000-4-4:2012 and IEC 61000-4-4:2012  
EN 61000-4-5: 2014+A1:2017 and IEC 61000-4-5: 2014+A1:2017  
EN 61000-4-6:2014+AC:2015 and IEC 61000-4-6:2013  
EN 61000-4-8: 2010 and IEC 61000-4-8: 2009  
EN 61000-4-11: 2004+A1:2017 and IEC 61000-4-11: 2004+A1:2017

I attest to the accuracy of data and all measurements reported herein were performed by me or were made under my supervision and are correct to the best of my knowledge and belief. I assume full responsibility for the completeness of these measurements and vouch for the qualifications of all persons taking them.

The determination of the test results is determined by customer agreement, regulations or standard document specifications.

The Laboratory evaluates measurement inaccuracies based on regulatory or standard document specifications and is listed in the report for reference. The quantitative project part judges the conformity of the test results based on the evaluation results of the standard cited uncertainty, and the qualitative project does not temporarily evaluate the measurement uncertainty.

*Bert Chen*

Bert Chen / Director



**International Standards Laboratory Corp.**

**LT LAB:**

No. 120, Lane 180, Hsin Ho Rd., Lung-Tan Dist., Tao Yuan City 325, Taiwan  
Tel: 886-3-407-1718; Fax: 886-3-407-1738

# CE MARK TECHNICAL FILE

## AS/NZS EMC CONSTRUCTION FILE

of

Product Name

**PCIe CFexpress**

Model

**PV130-CFX**

Brand

**Apacer**

Contains:

1. Declaration of Conformity
2. EN 55032/CISPR 32, AS/NZS CISPR 32 EMI test report
3. EN 55024/CISPR 24, EN 61000-3-2 / IEC 61000-3-2, and EN 61000-3-3 / IEC 61000-3-3 test report
4. Block Diagram and Schematics
5. Users' manual

### Declaration of Conformity

Name of Responsible Party: Apacer Technology Inc.  
Address of Responsible Party: 1F., No.32, Zhongcheng Rd., Tucheng Dist.,  
New Taipei City 236, Taiwan , R.O.C.  
Declares that product: PCIe CFexpress  
Model: PV130-CFX  
Brand: Apacer  
Assembled by: Same as above  
Address: Same as above

Conforms to the EMC Directive 2014/30/EU as attested by conformity with the following harmonized standards:

EN 55032:2015+AC:2016, CISPR 32: 2015+COR1:2016: Class B:  
Electromagnetic compatibility of multimedia equipment - Emission requirements.  
AS/NZS CISPR 32:2015: Class B: Electromagnetic compatibility of multimedia  
equipment- Emission requirements

Performed Item	Test Performed	Deviation	Result
Conducted emissions from the AC mains power ports	Yes	No	PASS
Telecommunication Port Conducted Emissions (asymmetric mode)	N/A	N/A	N/A
Radiated emissions at frequencies below 1 GHz	Yes	No	PASS
Radiated emissions at frequencies above 1 GHz	Yes	No	PASS
Radiated emissions from FM receivers	N/A	N/A	N/A
Voltage Disturbance Emissions at Antenna Terminals	N/A	N/A	N/A
Differential voltage emissions	N/A	N/A	N/A
Outdoor units of home satellite receiving systems	N/A	N/A	N/A

<to be continued>

EN 55024:2010+A1:2015 and CISPR 24:2010+A1:2015: Information technology equipment-Immunity characteristics - Limits and methods of measurement.

Standard	Description	Results	Criteria
EN 61000-4-2:2009 IEC 61000-4-2:2008	Electrostatic Discharge	Pass	B
EN 61000-4-3:2006+A1:2008 +A2:2010 IEC 61000-4-3:2006+A1:2007+A2:2010	Radio-Frequency, Electromagnetic Field	Pass	A
EN 61000-4-4:2012 IEC 61000-4-4:2012	Electrical Fast Transient/Burst	Pass	B
EN 61000-4-5:2014+A1:2017 IEC 61000-4-5:2014+A1:2017	Surge	Pass	B
EN 61000-4-6:2014+AC:2015 IEC 61000-4-6:2013	Conductive Disturbance	Pass	A
EN 61000-4-8:2010 IEC 61000-4-8:2009	Power Frequency Magnetic Field	Pass	A
EN 61000-4-11:2004+A1:2017 IEC 61000-4-11:2004+A1:2017	Voltage Dips / Short Interruption and Voltage Variation		
	>95% in 0.5 period	Pass	B
	30% in 25 period	Pass	C
	>95% in 250 period	Pass	C

Standard	Description	Results
EN 61000-3-2:2014 IEC 61000-3-2:2014	Limits for harmonics current emissions	Pass
EN 61000-3-3:2013 IEC 61000-3-3:2013	Limits for voltage fluctuations and flicker in low-voltage supply systems.	Pass

*We, Apacer Technology Inc., hereby declare that the equipment bearing the trade name and model number specified above was tested conforming to the applicable Rules under the most accurate measurement standards possible, and that all the necessary steps have been taken and are in force to assure that production units of the same equipment will continue to comply with the requirements.*

-----  
Sheng-Wei Yu  
Apacer Technology Inc.

**Date: September 23, 2019**

Remarks: 1) The responsible party for Declaration of Conformity must be located within Europe, 2) The above is a sample of DoC, one should modify it to meet remark 1.

## Declaration of Conformity

Name of Responsible Party: Apacer Technology Inc.  
Address of Responsible Party: 1F., No.32, Zhongcheng Rd., Tucheng Dist.,  
New Taipei City 236, Taiwan , R.O.C.  
Declares that product: PCIe CFexpress  
Model: PV130-CFX  
Brand: Apacer  
Assembled by: Same as above  
Address: Same as above

Conforms to the EMI part of RCM Mark requirements as attested by conformity with the following standards:

AS/NZS CISPR 32:2015: Class B: Electromagnetic compatibility of multimedia equipment- Emission requirements

*We, Apacer Technology Inc., hereby declare that the equipment bearing the trade name and model number specified above was tested conforming to the applicable Rules under the most accurate measurement standards possible, and that all the necessary steps have been taken and are in force to assure that production units of the same equipment will continue to comply with the requirements.*

-----  
Sheng-Wei Yu  
Apacer Technology Inc.

**Date: September 23, 2019**

# CE TEST REPORT

of  
**EN 55032 / CISPR 32 / AS/NZS CISPR 32**  
**Class B**  
**EN 55024 / CISPR 24 / IMMUNITY**  
**EN 61000-3-2 / EN 61000-3-3**

Product : **PCIe CFexpress**

Model(s): **PV130-CFX**

Brand: **Apacer**

Applicant: **Apacer Technology Inc.**

Address: **1F., No.32, Zhongcheng Rd., Tucheng Dist.,  
New Taipei City 236, Taiwan , R.O.C.**

Test Performed by:

**International Standards Laboratory Corp.**

<LT LAB>

\*Address:

No. 120, Lane 180, Hsin Ho Rd.,  
Lung-Tan Dist., Tao Yuan City 325, Taiwan

\*Tel: 886-3-407-1718; Fax: 886-3-407-1738

Report No.: **ISL-19LE512CE-MA**

Issue Date : **September 23, 2019**

This report totally contains 62 pages including this cover page and contents page.

Test results given in this report apply only to the specific sample(s) tested and are traceable to national or international standard through calibration of the equipment and evaluating measurement uncertainty herein.

This test report shall not be reproduced except in full, without the written approval of International Standards Laboratory Corp.

## Contents of Report

1.	General.....	1
1.1	Certification of Accuracy of Test Data .....	1
1.2	Test Standards .....	2
1.3	Description of EUT .....	5
1.4	Description of Support Equipment .....	6
1.5	Software for Controlling Support Unit.....	7
1.6	I/O Cable Condition of EUT and Support Units .....	8
2.	Power Main Port Conducted Emissions .....	9
2.1	Test Setup and Procedure .....	9
2.2	Conduction Test Data: Configuration 1 .....	11
2.3	Test Setup Photo.....	13
3.	Telecommunication Port Conducted Emissions .....	15
3.1	Test Setup and Procedure .....	15
4.	Radiated Disturbance Emissions .....	17
4.1	Test Setup and Procedure .....	17
4.2	Limit .....	19
4.3	Radiation Test Data: Configuration 1.....	21
4.4	Test Setup Photo.....	25
5.	Voltage Disturbance Emissions at Antenna Terminals .....	27
5.1	Test Setup and Procedure .....	27
6.	Differential Voltage Emissions.....	29
6.1	Test Setup and Procedure .....	29
7.	Outdoor units of home satellite receiving systems .....	31
7.1	Test Setup and Procedure .....	31
8.	Electrostatic discharge (ESD) immunity .....	33
8.1	Test Specification and Setup .....	33
8.2	Test Point.....	34
8.3	Test Setup Photo.....	35
9.	Radio-Frequency, Electromagnetic Field immunity.....	36
9.1	Test Specification and Setup .....	36
9.2	Test Setup Photo.....	37
10.	Electrical Fast transients/burst immunity .....	38
10.1	Test Specification and Setup .....	38
10.2	Test Setup Photo .....	40
11.	Surge Immunity .....	41
11.1	Test Specification and Setup .....	41
11.2	Test Setup Photo .....	42
12.	Immunity to Conductive Disturbance.....	43
12.1	Test Specification and Setup .....	43
12.2	Test Setup Photo .....	44
13.	Power Frequency Magnetic Field immunity .....	45
13.1	Test Specification and Setup .....	45
13.2	Test Setup Photo .....	46
14.	Voltage Dips, Short Interruption and Voltage Variation immunity .....	47
14.1	Test Specification and Setup .....	47
14.2	Test Setup Photo .....	48
15.	Harmonics .....	49
15.1	Test Specification and Setup .....	49

16.	Voltage Fluctuations .....	51
16.1	Test Specification and Setup .....	51
16.2	Test Data .....	52
16.3	Test Setup Photo .....	53
17.	Appendix.....	54
17.1	Appendix A: Test Equipment.....	54
17.2	Appendix B: Uncertainty of Measurement .....	57
17.3	Appendix C: Photographs of EUT Please refer to the File of ISL-19LE512P-MA....	59

ISL  
Draft

## 1. General

### 1.1 Certification of Accuracy of Test Data

**Standards:** Please refer to 1.2

**Equipment Tested:** PCIe CFexpress

**Model:** PV130-CFX

**Brand:** Apacer

**Applicant:** Apacer Technology Inc.

**Sample received Date:** August 20, 2019

**Final test Date:** EMI: refer to the date of test data  
EMS: August 30, 2019

**Test Site:** Chamber 02; Chamber 14; Conduction 02; Immunity 02

**Test Distance:** 10M; 3M (above1GHz) (EMI test)

**Temperature:** refer to each site test data

**Humidity:** refer to each site test data

**Atmospheric Pressure:** 86 kPa to 106 kPa

**Input power:** Conduction input power: AC 230 V / 50 Hz  
Radiation input power: AC 230 V / 50 Hz  
Immunity input power: AC 230 V / 50 Hz

**Test Result:** **PASS**

**Report Engineer:** Cheryl Tung

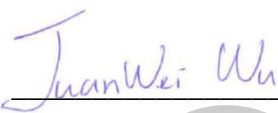
**Test Engineer:**   
Juanwei Wu

**Approved By:**   
Angus Chu / Director

## 1.2 Test Standards

The tests which this report describes were conducted by an independent electromagnetic compatibility consultant, International Standards Laboratory Corp. in accordance with the following

EN 55032:2015+AC:2016, CISPR 32: 2015+COR1:2016: Class B: Electromagnetic compatibility of multimedia equipment - Emission requirements.

AS/NZS CISPR 32:2015: Class B: Electromagnetic compatibility of multimedia equipment- Emission requirements

Performed Item	Test Performed	Deviation	Result
Conducted emissions from the AC mains power ports	Yes	No	PASS
Telecommunication Port Conducted Emissions (asymmetric mode)	N/A	N/A	N/A
Radiated emissions at frequencies below 1 GHz	Yes	No	PASS
Radiated emissions at frequencies above 1 GHz	Yes	No	PASS
Radiated emissions from FM receivers	N/A	N/A	N/A
Voltage Disturbance Emissions at Antenna Terminals	N/A	N/A	N/A
Differential voltage emissions	N/A	N/A	N/A
Outdoor units of home satellite receiving systems	N/A	N/A	N/A

EN 55024:2010+A1:2015 and CISPR 24:2010+A1:2015: Information technology equipment-Immunity characteristics - Limits and methods of measurement.

Standard	Description	Results	Criteria
EN 61000-4-2:2009 IEC 61000-4-2:2008	Electrostatic Discharge	Pass	B
EN 61000-4-3:2006+A1:2008 +A2:2010 IEC 61000-4-3:2006+A1:2007+A2:2010	Radio-Frequency, Electromagnetic Field	Pass	A
EN 61000-4-4:2012 IEC 61000-4-4:2012	Electrical Fast Transient/Burst	Pass	B
EN 61000-4-5:2014+A1:2017 IEC 61000-4-5:2014+A1:2017	Surge	Pass	B
EN 61000-4-6:2014+AC:2015 IEC 61000-4-6:2013	Conductive Disturbance	Pass	A
EN 61000-4-8:2010 IEC 61000-4-8:2009	Power Frequency Magnetic Field	Pass	A
EN 61000-4-11:2004+A1:2017 IEC 61000-4-11:2004+A1:2017	Voltage Dips / Short Interruption and Voltage Variation		
	>95% in 0.5 period	Pass	B
	30% in 25 period	Pass	C
	>95% in 250 period	Pass	C

Standard	Description	Results
EN 61000-3-2:2014 IEC 61000-3-2:2014	Limits for harmonics current emissions	Pass
EN 61000-3-3:2013 IEC 61000-3-3:2013	Limits for voltage fluctuations and flicker in low-voltage supply systems.	Pass

### 1.2.1 Performance Criteria for Compliance: EN 55024

#### **Performance criterion A**

During and after the test the EUT shall continue to operate as intended without operator intervention. No degradation of performance or loss of function is allowed below a minimum performance level specified by the manufacturer when the EUT is used as intended. The performance level may be replaced by a permissible loss of performance. If the minimum performance level or the permissible performance loss is not specified by the manufacturer, then either of these may be derived from the product description and documentation, and by what the user may reasonably expect from the EUT if used as intended.

#### **Performance criterion B**

After the test, the EUT shall continue to operate as intended without operator intervention. No degradation of performance or loss of function is allowed, after the application of the phenomena below a performance level specified by the manufacturer, when the EUT is used as intended. The performance level may be replaced by a permissible loss of performance. During the test, degradation of performance is allowed. However, no change of operating state or stored data is allowed to persist after the test. If the minimum performance level (or the permissible performance loss) is not specified by the manufacturer, then either of these may be derived from the product description and documentation, and by what the user may reasonably expect from the EUT if used as intended.

#### **Performance criterion C**

During and after testing, a temporary loss of function is allowed, provided the function is self-recoverable, or can be restored by the operation of the controls or cycling of the power to the EUT by the user in accordance with the manufacturer's instructions.

Functions, and/or information stored in non-volatile memory, or protected by a battery backup, shall not be lost.

### 1.3 Description of EUT

## EUT

**This report test data using the report number 19LE512CE**

Description	PCIe CFexpress
Condition	Pre-Production
Model	PV130-CFX
Serial Number	N/A
Power	From Personal Computer Supply
Control IC	PS5008
PCB Number	Q023008GF004801E
Memory Capacity	480GB
Highest working frequency	5GHz

The memory capacities listed below is chosen by the applicant to be the representative configuration for testing in this report.

#### Test configurations:

Configuration	Control IC	PCB Number	Memory Capacity
1	PS5008	Q023008GF004801E	480GB

#### EMI Noise Source:

Refer to the photo	Crystal	Point
EUT-7	25MHz	Y1

#### EMI Solution:

NA

#### 1.4 Description of Support Equipment

For EMI test Configuration Support unit: 1~6

For EMS test Configuration Support unit: 2~7

No	Unit	Model / Serial No.	Brand	Power Cord	FCC ID
1	LCD Monitor	P2416D S/N: N/A	DELL	Non-shielded	FCC DOC
2	PS/2 Keyboard	Y-S0002 S/N: N/A	Logitech	N/A	FCC DOC
3	PS/2 Mouse	M-SBM96B S/N: N/A	Logitech	N/A	FCC DOC
4	Printer	C930 S/N: N/A	HP	Non-shielded	FCC DOC
5	Modem	DM1414 S/N: N/A	Aceex	Non-shielded	FCC DOC
6	Personal Computer	HP ProDesk 400 G3 MT S/N: N/A	HP	Non-shielded	FCC DOC
7	LCD Monitor	ST2420L S/N: N/A	DELL	Non-shielded	FCC DOC

### 1.5 Software for Controlling Support Unit

Test programs exercising various part of EUT were used. The programs were executed as follows:

1. PC running Winthrax.exe to read and write the EUT.
2. Send signal to the Printer through PC USB Port.
3. Send signal to the Modem through PC Serial Port.
4. Send Color Bar to the LCD Monitor through PC D-SUB Port.
5. Repeat the above steps.

	<b>Filename</b>	<b>Issued Date</b>
EUT	Winthrax.exe	06/14/2005
LCD Monitor	Media Player.exe	11/04/2009
Printer	IntelEMC	04/11/2007
Modem	IntelEMC	04/11/2007

### 1.6 I/O Cable Condition of EUT and Support Units

Description	Path	Cable Length	Cable Type
AC Power Cable	110V (~240V) to PC SPS	1.8m	Non-shielded
Monitor Data Cable	Monitor D-SUB Port to PC D-SUB Port	1.8m	Shielded (with core)
Keyboard Data Cable	PS/2 Keyboard to PC PS/2 Port	1.8m	Shielded
Mouse Data Cable	PS/2 Mouse to PC PS/2 Port	1.8m	Shielded
Printer Data Cable	Printer to PC USB Port	1.8m	Shielded
Modem Data Cable	Modem to PC Serial Port	1.8m	Shielded

## 2. Power Main Port Conducted Emissions

### 2.1 Test Setup and Procedure

#### 2.1.1 Test Setup

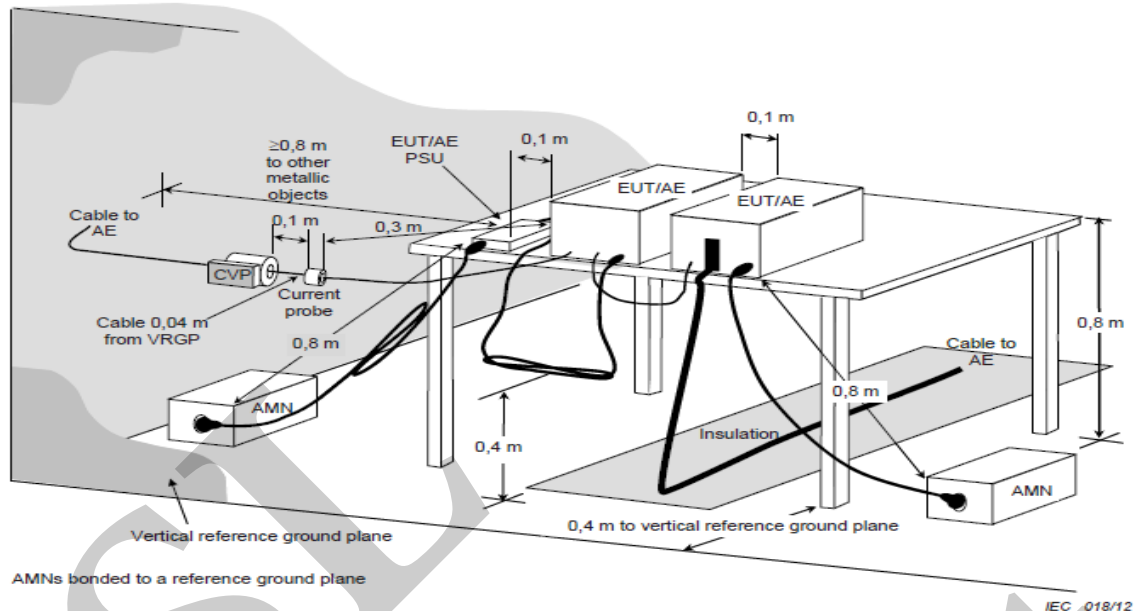

#### 2.1.2 Test Procedure

The measurements are performed in a shielded room test site. The EUT was placed on non-conduction 1.0m x 1.5m table, which is 0.8 meters above an earth-grounded.

Power to the EUT was provided through the LISN which has the Impedance (50ohm/50uH) vs. Frequency Characteristic in accordance with the standard. Power to the LISNs were filtered to eliminate ambient signal interference and these filters were bonded to the ground plane. Peripheral equipment required to provide a functional system (support equipment) for EUT testing was powered from the second LISN through a ganged, metal power outlet box which is bonded to the ground plane at the LISN.

The interconnecting cables were arranged and moved to get the maximum measurement. Both the line of power cord, live and neutral, were measured. All of the interface cables were manipulated according to EN 55032 requirements.

The highest emissions were analyzed in details by operating the spectrum analyzer in fixed tuned mode to determine the nature of the emissions and to provide information which could be useful in reducing their amplitude.

#### 2.1.3 EMI Receiver/Spectrum Analyzer Configuration (for the frequencies tested)

Frequency Range:	150kHz--30MHz
Detector Function:	Quasi-Peak / Average Mode
Resolution Bandwidth:	9kHz

**2.1.4 Limit**

**Conducted emissions from the AC mains power ports of Class\_A equipment:**

Frequency	QP	AV
MHz	dB( $\mu$ V)	dB( $\mu$ V)
0.15-0.50	79	66
0.50-30	73	60

Note: The lower limit shall apply at the transition frequencies

**Conducted emissions from the AC mains power ports of Class\_B equipment:**

Frequency	QP	AV
MHz	dB( $\mu$ V)	dB( $\mu$ V)
0.15-0.50	66-56	56-46
0.50-5.0	56	46
5.0-30	60	50

Note: The lower limit shall apply at the transition frequencies

ISL  
Draft

## 2.2 Conduction Test Data: Configuration 1 -Live

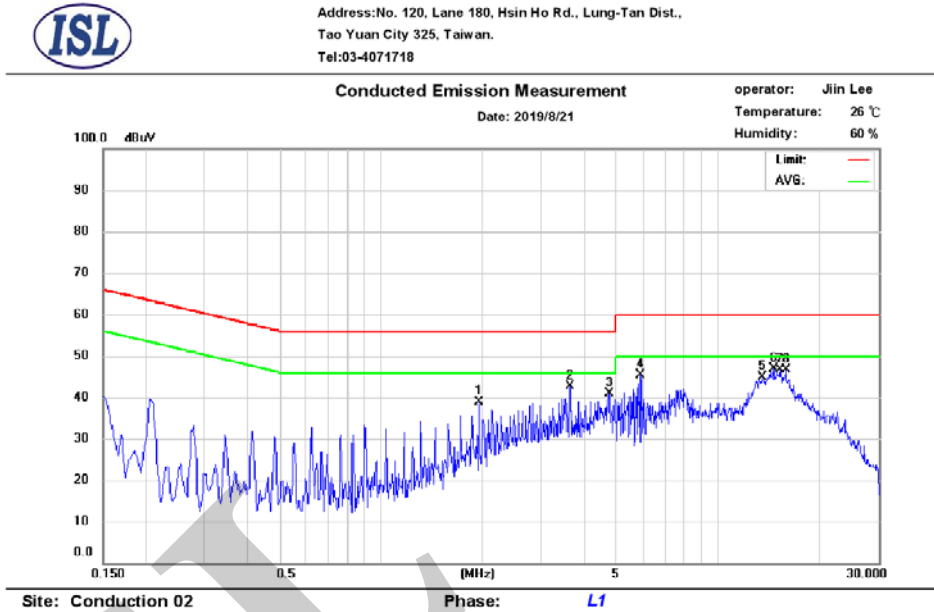

No.	Frequency (MHz)	QP_R (dBuV)	AVG_R (dBuV)	Correct Factor (dB)	QP Emission (dBuV)	QP Limit (dBuV)	QP Margin (dB)	AVG Emission (dBuV)	AVG Limit (dBuV)	AVG Margin (dB)
1	1.958	26.06	16.76	9.69	35.75	56.00	-20.25	26.45	46.00	-19.55
2	3.646	38.02	26.56	9.73	47.75	56.00	-8.25	36.29	46.00	-9.71
3	4.770	28.19	26.98	9.76	37.95	56.00	-18.05	36.74	46.00	-9.26
4	5.874	32.31	26.70	9.77	42.08	60.00	-17.92	36.47	50.00	-13.53
5	13.598	31.05	25.75	9.89	40.94	60.00	-19.06	35.64	50.00	-14.36
6	14.610	31.89	26.45	9.89	41.78	60.00	-18.22	36.34	50.00	-13.66
7	15.230	31.38	26.24	9.89	41.27	60.00	-18.73	36.13	50.00	-13.87
8	15.922	30.71	25.50	9.90	40.61	60.00	-19.39	35.40	50.00	-14.60

Note:

Margin = QP/AVG Emission - Limit

QP/AVG Emission = QP\_R/AVG\_R + Correct Factor

Correct Factor = LISN Loss + Cable Loss

A margin of -8dB means that the emission is 8dB below the limit

The frequency spectrum graph is for final peak graph, and the attached table is for QP/AVG test result.

If peak data can pass, it will be shown in "QP/AVG Correct" column, if not, QP/AVG data will instead.

- Neutral



Address: No. 120, Lane 180, Hsin Ho Rd., Lung-Tan Dist.,  
Tao Yuan City 325, Taiwan.  
Tel: 03-4071718

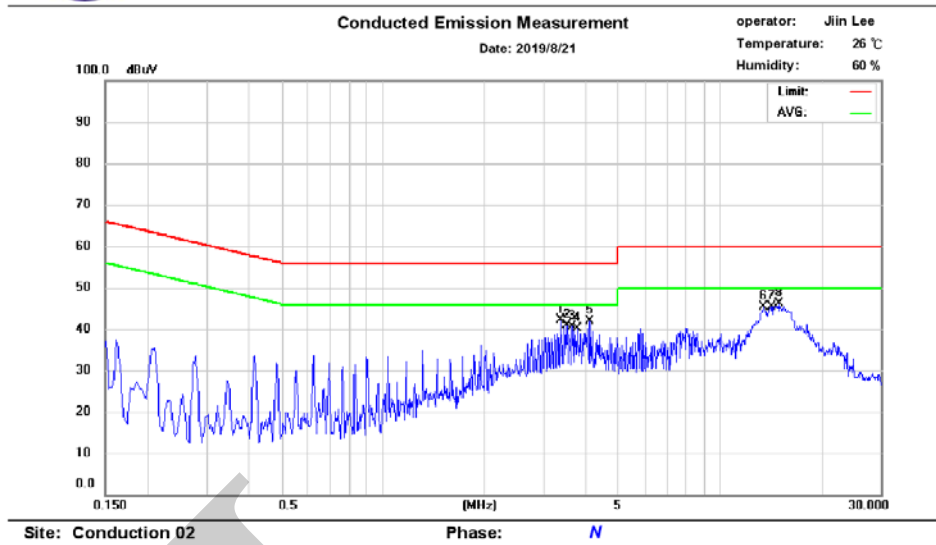

No.	Frequency (MHz)	QP_R (dBuV)	AVG_R (dBuV)	Correct Factor (dB)	QP Emission (dBuV)	QP Limit (dBuV)	QP Margin (dB)	AVG Emission (dBuV)	AVG Limit (dBuV)	AVG Margin (dB)
1	3.374	34.90	27.08	9.75	44.65	56.00	-11.35	36.83	46.00	-9.17
2	3.510	34.16	26.82	9.75	43.91	56.00	-12.09	36.57	46.00	-9.43
3	3.646	38.39	26.50	9.75	48.14	56.00	-7.86	36.25	46.00	-9.75
4	3.786	27.73	19.71	9.76	37.49	56.00	-18.51	29.47	46.00	-16.53
5	4.118	32.66	22.33	9.76	42.42	56.00	-13.58	32.09	46.00	-13.91
6	13.434	31.76	26.95	9.93	41.69	60.00	-18.31	36.88	50.00	-13.12
7	14.218	31.74	26.60	9.94	41.68	60.00	-18.32	36.54	50.00	-13.46
8	15.006	31.46	26.35	9.96	41.42	60.00	-18.58	36.31	50.00	-13.69

Note:

Margin = QP/AVG Emission - Limit

QP/AVG Emission = QP\_R/AVG\_R + Correct Factor

Correct Factor = LISN Loss + Cable Loss

A margin of -8dB means that the emission is 8dB below the limit

The frequency spectrum graph is for final peak graph, and the attached table is for QP/AVG test result.

If peak data can pass, it will be shown in "QP/AVG Correct" column, if not, QP/AVG data will instead.

### 2.3 Test Setup Photo

Front View



ISL  
Draft

Back View

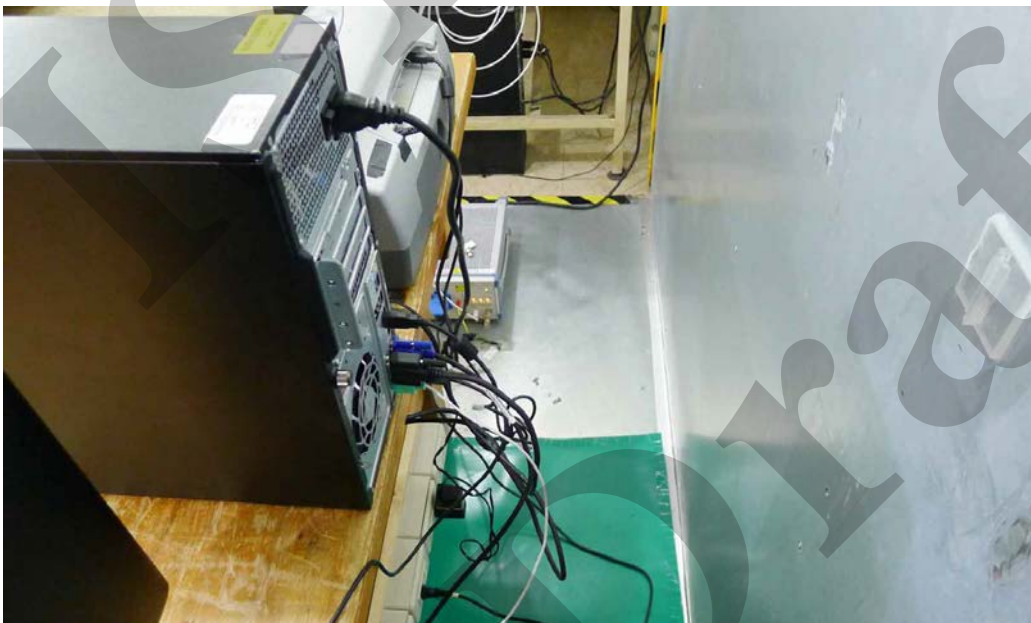

### 3. Telecommunication Port Conducted Emissions

#### 3.1 Test Setup and Procedure

##### 3.1.1 Test Setup

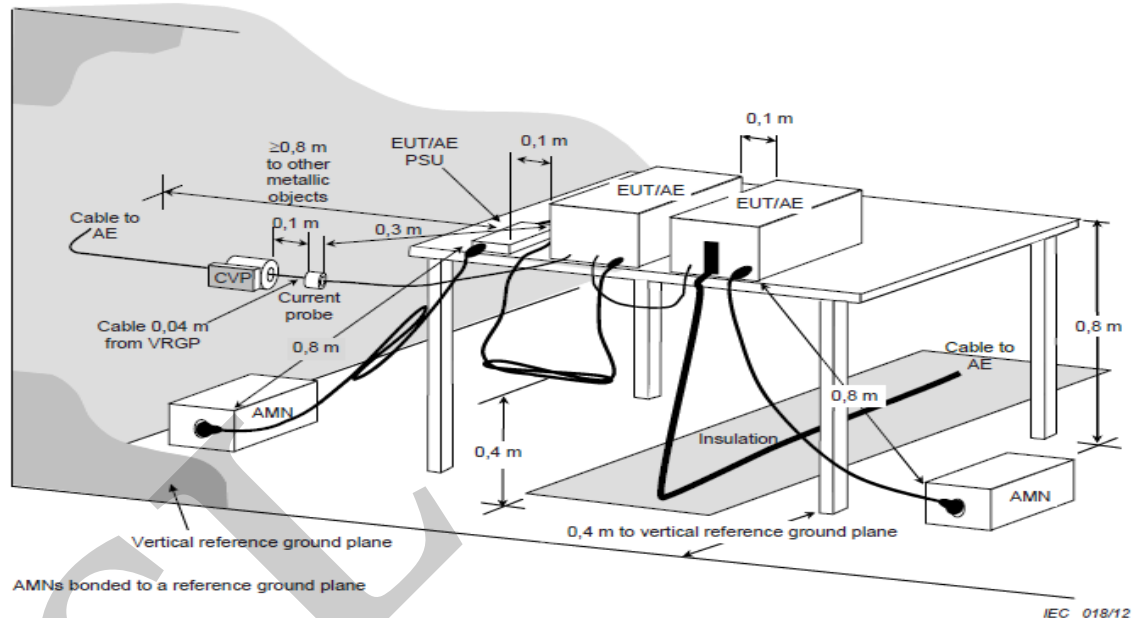

##### 3.1.2 Test Procedure

The measurements are performed in a shielded room test site. The EUT was placed on non-conduction 1.0m x 1.5m table, which is 0.8 meters above an earth-grounded.

The EUT, any support equipment, and any interconnecting cables were arranged and moved to get the maximum measurement. All of the interface cables were manipulated according to EN 55032 requirements.

The port of the EUT was connected to the support equipment through the ISN and linked in normal condition.

AC input power for the EUT & the support equipment power outlets were obtained from the same filtered source that provided input power to the LISN.

The highest emissions were analyzed in details by operating the spectrum analyzer in fixed tuned mode to determine the nature of the emissions and to provide information could be useful in reducing their amplitude.

##### 3.1.3 EMI Receiver/Spectrum Analyzer Configuration (for the frequencies tested)

Frequency Range:	150kHz--30MHz
Detector Function:	Quasi-Peak / Average Mode
Resolution Bandwidth:	9kHz

### 3.1.4 Limit

Asymmetric mode conducted emissions from Class\_A equipment:

Applicable to

1. wired network ports.
2. optical fibre ports with metallic shield or tension members.
3. antenna ports.

Frequency range MHz	Coupling device	Detector type / bandwidth	Class_A voltage limits dB( $\mu$ V)	Class_A current limits dB( $\mu$ A)
0.15-0.5	AAN	Quasi Peak / 9 kHz	97-87	n/a
0.5-30			87	
0.15-0.5	AAN	Average / 9 kHz	84-74	
0.5-30			74	
0.15-0.5	CVP and current probe	Quasi Peak / 9 kHz	97-87	53-43
0.5-30			87	43
0.15-0.5	CVP and current probe	Average / 9 kHz	84-74	40-30
0.5-30			74	30
0.15-0.5	Current Probe	Quasi Peak / 9 kHz	n/a	53-43
0.5-30				43
0.15-0.5	Current Probe	Average / 9 kHz		40-30
0.5-30				30

Asymmetric mode conducted emissions from Class\_B equipment:

Applicable to:

1. wired network ports.
2. optical fibre ports with metallic shield or tension members.
3. broadcast receiver tuner ports.
4. antenna ports.

Frequency range MHz	Coupling device	Detector type / bandwidth	Class_B voltage limits dB( $\mu$ V)	Class_B current limits dB( $\mu$ A)
0.15-0.5	AAN	Quasi Peak / 9 kHz	84-74	n/a
0.5-30			74	
0.15-0.5	AAN	Average / 9 kHz	74-64	
0.5-30			64	
0.15-0.5	CVP and current probe	Quasi Peak / 9 kHz	84-74	40-30
0.5-30			74	30
0.15-0.5	CVP and current probe	Average / 9 kHz	74-64	30-20
0.5-30			64	20
0.15-0.5	Current Probe	Quasi Peak / 9 kHz	n/a	40-30
0.5-30				30
0.15-0.5	Current Probe	Average / 9 kHz		30-20
0.5-30				20

**\*\*Remarks: It is not necessary to be tested on this item.**

## 4. Radiated Disturbance Emissions

### 4.1 Test Setup and Procedure

#### 4.1.1 Test Setup

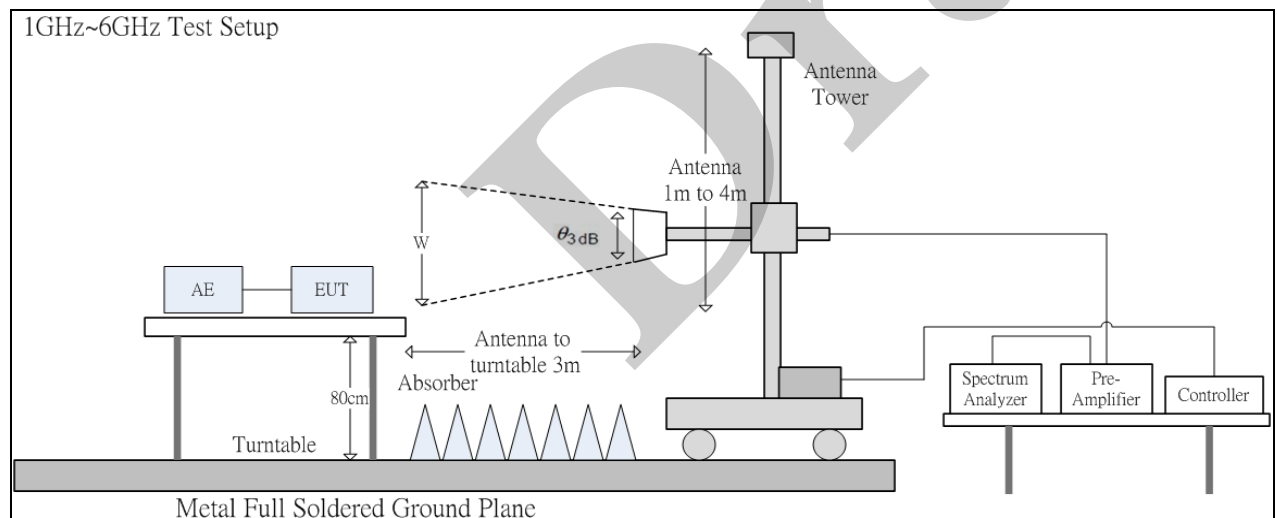
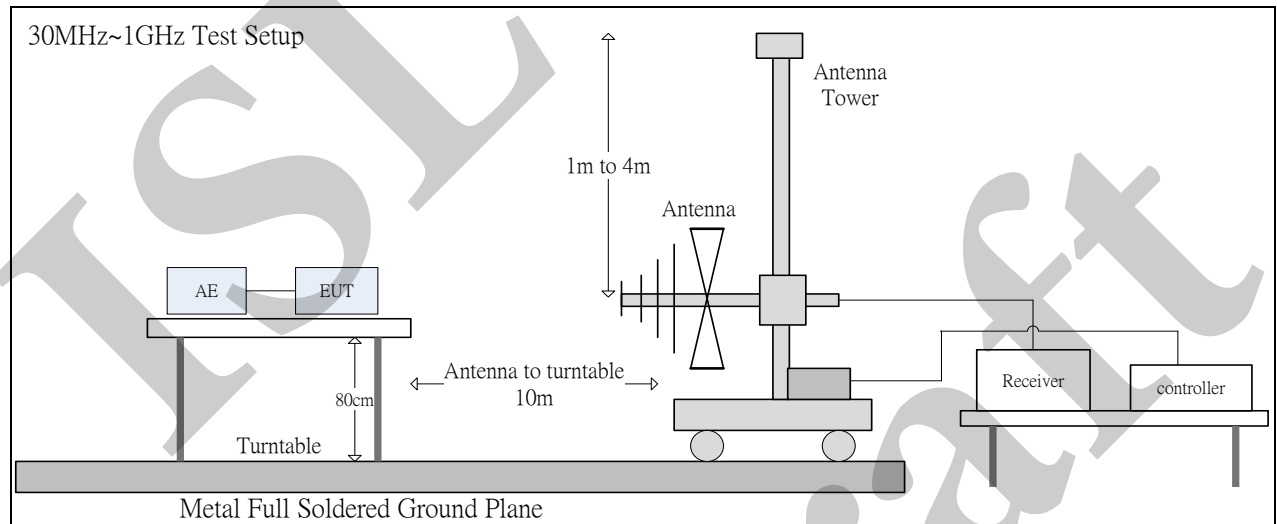
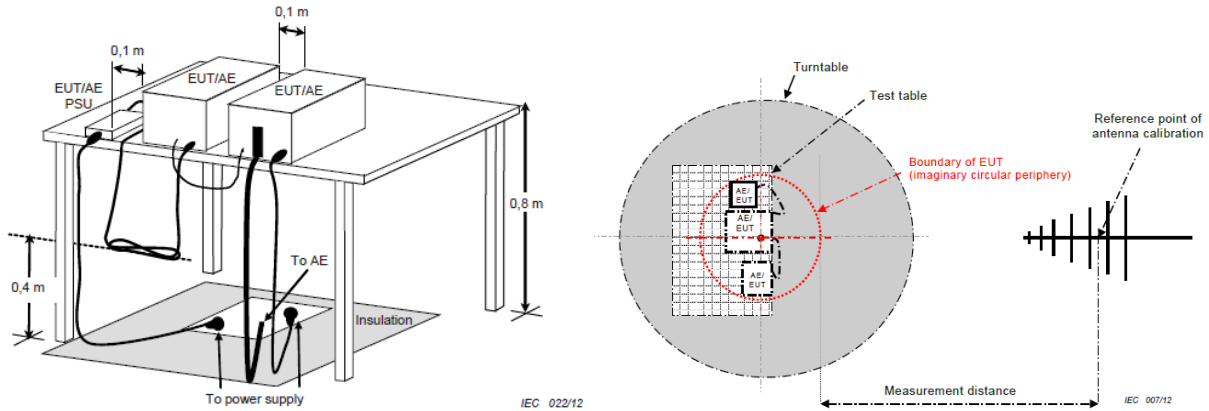

The 3dB beam width of the horn antenna used for the test is as shown in the table below.

Frequency (GHz)	E-plane	H-plane	$\theta_{3\text{dB}}(\text{min})$	d= 3 m
				w (m)
1	88°	147°	88°	5.79
2	68°	119°	68°	4.04
3	73°	92°	73°	4.44
4	70°	89°	70°	4.20
5	55°	60°	55°	3.12
6	63°	62°	62°	3.60

#### 4.1.2 Test Procedure

The radiated emissions test will then be repeated on the open site or chamber to measure the amplitudes accurately and without the multiple reflections existing in the shielded room. The EUT and support equipment are set up on the turntable of one of 10 meter open field sites or 10 meter chamber. Desktop EUT are set up on a FRP stand 0.8 meter above the ground or floor-standing arrangement shall be placed on the horizontal ground reference plane.

For the initial measurements, the receiving antenna is varied from 1-4 meter height and is changed in the vertical plane from vertical to horizontal polarization at each frequency. The highest emissions between 30 MHz to 1000 MHz were analyzed in details by operating the spectrum analyzer and/or EMI receiver in quasi-peak mode to determine the precise amplitude of the emissions. The highest emissions between 1 GHz to 6 GHz were analyzed in details by operating the spectrum analyzer in peak and average mode to determine the precise amplitude of the emissions. The test volume for a height of up to 30 cm may be obstructed by absorber placed on the ground plane.

At the highest amplitudes observed, the EUT is rotated in the horizontal plane while changing the antenna polarization in the vertical plane to maximize the reading. The interconnecting cables were arranged and moved to get the maximum measurement. Once the maximum reading is obtained, the antenna elevation and polarization will be varied between specified limits to maximize the readings. All of the interface cables were manipulated according to EN 55032 requirements.

The highest internal source of an EUT is defined as the highest frequency generated or used within the EUT or on which the EUT operates or tunes.

If the highest frequency of the internal sources of the EUT is less than 108 MHz, the measurement shall only be made up to 1 GHz.

If the highest frequency of the internal sources of the EUT is between 108 MHz and 500 MHz, the measurement shall only be made up to 2 GHz.

If the highest frequency of the internal sources of the EUT is between 500 MHz and 1 GHz, the measurement shall only be made up to 5 GHz.

If the highest frequency of the internal sources of the EUT is above 1 GHz, the measurement shall be made up to 5 times the highest frequency or 6 GHz, whichever is less.

### 4.1.3 Spectrum Analyzer Configuration (for the frequencies tested)

Frequency Range: 30MHz--1000MHz  
 Detector Function: Quasi-Peak Mode  
 Resolution Bandwidth: 120kHz

Frequency Range: Above 1 GHz to 6 GHz  
 Detector Function: Peak/Average Mode  
 Resolution Bandwidth: 1MHz

## 4.2 Limit

### Radiated emissions at frequencies up to 1 GHz for Class\_A equipment:

Frequency range MHz	Measurement		Class_A limits dB( $\mu$ V/m)
	Distance m	Detector type / bandwidth	OATS/SAC
30-230	10	Quasi Peak / 120 kHz	40
230-1000			47
30-230	3		50
230-1000			57

### Radiated emissions at frequencies above 1 GHz for Class\_A equipment:

Frequency range MHz	Measurement		Class_A limits dB( $\mu$ V/m)
	Distance m	Detector type / bandwidth	FSOATS
1000-3000	3	Average / 1MHz	56
3000-6000			60
1000-3000		Peak / 1MHz	76
3000-6000			80

### Radiated emissions at frequencies up to 1 GHz for Class\_B equipment:

Frequency range MHz	Measurement		Class_B limits dB( $\mu$ V/m)
	Distance m	Detector type / bandwidth	OATS/SAC
30-230	10	Quasi Peak / 120 kHz	30
230-1000			37
30-230	3		40
230-1000			47

**Radiated emissions at frequencies above 1 GHz for Class\_B equipment:**

Frequency range MHz	Measurement		Class_B limits dB( $\mu$ V/m)
	Distance m	Detector type / bandwidth	FSOATS
1000-3000	3	Average / 1MHz	50
3000-6000			54
1000-3000		Peak / 1MHz	70
3000-6000			74

**Radiated emissions from FM receivers:**

Frequency range MHz	Measurement		Class_B limits dB( $\mu$ V/m)		
	Distance m	Detector type / bandwidth	Fundamental	Harmonics	
			OATS/SAC	OATS/SAC	
30-230	10	Quasi Peak / 120 kHz	50	42	
230-300				42	
300-1000				46	
30-230	3		Quasi Peak / 120 kHz	60	52
230-300					52
300-1000					56

### 4.3 Radiation Test Data: Configuration 1 - Radiated Emissions (Horizontal)



Address: No. 120, Lane 180, Hsin Ho Rd., Lung-Tan Dist.,  
Tao Yuan City 325, Taiwan.  
Tel: 03-4071718

Radiated Emission Measurement  
Date: 2019/8/20  
Operator: Jerry Su  
Temperature: 26 °C  
Humidity: 60 %

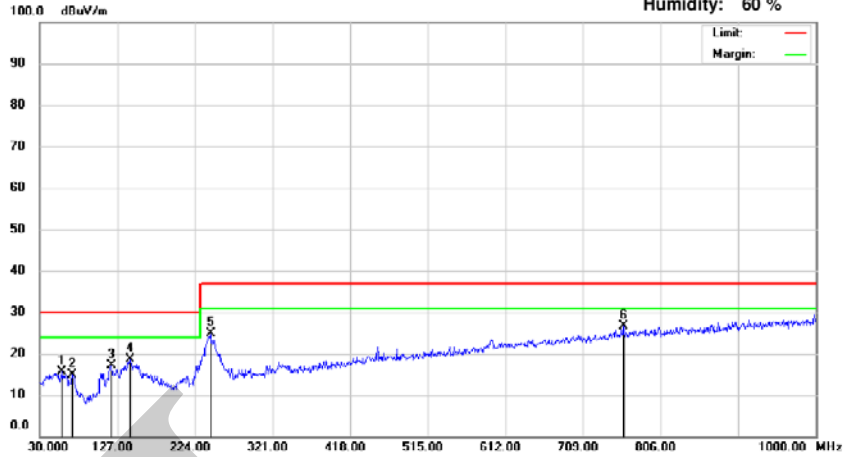

Site : Chamber 02

Polarization: *Horizontal*

Mk.	Frequency (MHz)	RX_R (dBuV)	Correct Factor (dB/m)	Emission (dBuV/m)	Limit (dBuV/m)	Margin (dB)	Ant.Pos (cm)	Tab.Pos (deg.)	Detector
1	58.13	33.06	-17.40	15.66	30.00	-14.34	200	100	QP
2	70.74	34.11	-19.17	14.94	30.00	-15.06	400	104	QP
3	119.24	35.83	-18.69	17.14	30.00	-12.86	400	133	QP
4	142.52	35.12	-16.44	18.68	30.00	-11.32	400	323	QP
5	243.40	41.73	-16.94	24.79	37.00	-12.21	200	140	QP
6	759.44	31.53	-4.80	26.73	37.00	-10.27	200	117	QP

\* Note:

Margin = Emission – Limit

Emission = Radiated Amplitude + Correct Factor

Correct Factor = Antenna Correction Factor + Cable Loss – Pre-Amplifier Gain

A margin of -8dB means that the emission is 8dB below the limit

Antenna Distance: 10 meters

Below 1GHz test, if the peak measured value meets the QP limit, it is unnecessary to perform the QP measurement.



Address: No. 120, Lane 180, Hsin Ho Rd., Lung-Tan Dist.,  
Tao Yuan City 325, Taiwan.  
Tel: 03-4071718

Radiated Emission Measurement  
Date: 2019/8/21

Operator: Juanwei  
Temperature: 26 °C  
Humidity: 60 %

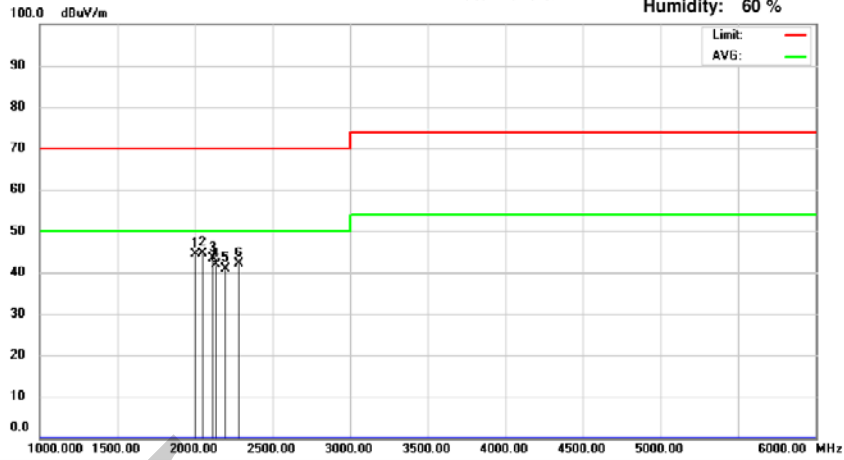

Site : Chamber 14

Polarization: Horizontal

Mk.	Frequency (MHz)	RX_R (dBuV)	Correct Factor(dB/m)	Emission (dBuV/m)	Limit (dBuV/m)	Margin (dB)	Ant.Pos (cm)	Tab.Pos (deg.)	Detector
1	2000.00	56.95	-12.56	44.39	70.00	-25.61	150	139	peak
2	2050.00	57.04	-12.53	44.51	70.00	-25.49	200	160	peak
3	2115.00	56.05	-12.69	43.36	70.00	-26.64	200	164	peak
4	2135.00	54.68	-12.80	41.88	70.00	-28.12	100	230	peak
5	2195.00	53.82	-12.85	40.97	70.00	-29.03	200	140	peak
6	2280.00	54.43	-12.37	42.06	70.00	-27.94	100	160	peak

\* Note:

Margin = Emission - Limit

Emission = Radiated Amplitude + Correct Factor

Correct Factor = Antenna Correction Factor + Cable Loss - Pre-Amplifier Gain

A margin of -8dB means that the emission is 8dB below the limit

Antenna Distance: 3 meters

Above 1GHz test, if the peak measured value meets the average limit, it is unnecessary to perform the average measurement.

**-Radiated Emissions (Vertical)**



Address: No. 120, Lane 180, Hsin Ho Rd., Lung-Tan Dist.,  
Tao Yuan City 325, Taiwan.  
Tel: 03-4071718

Radiated Emission Measurement  
Date: 2019/8/20

Operator: Jerry Su  
Temperature: 26 °C  
Humidity: 60 %

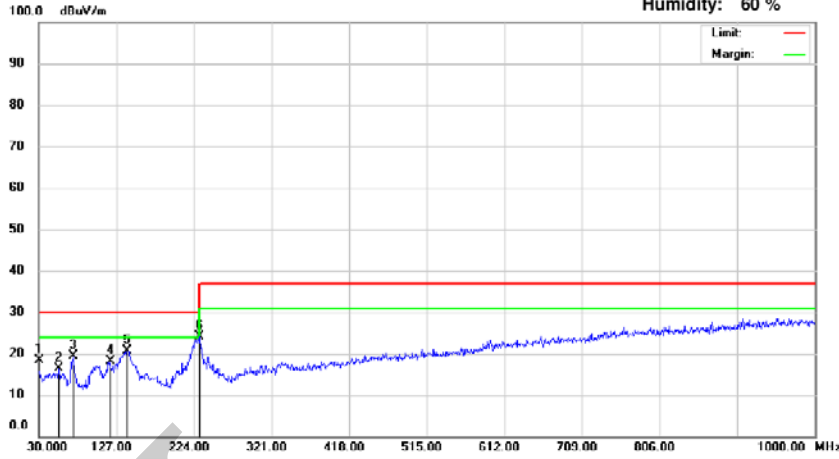

Site : Chamber 02

Polarization: Vertical

Mk.	Frequency (MHz)	RX R (dBuV)	Correct Factor (dB/m)	Emission (dBuV/m)	Limit (dBuV/m)	Margin (dB)	Ant.Pos (cm)	Tab.Pos (deg.)	Detector
1	30.00	37.19	-18.93	18.26	30.00	-11.74	100	186	QP
2	55.22	33.66	-17.16	16.50	30.00	-13.50	118	0	QP
3	72.68	38.74	-19.47	19.27	30.00	-10.73	300	195	QP
4	119.24	36.72	-18.69	18.03	30.00	-11.97	100	10	QP
5	140.58	37.25	-16.66	20.59	30.00	-9.41	100	30	QP
6	230.79	42.38	-18.37	24.01	37.00	-12.99	100	0	QP

\* Note:

Margin = Emission - Limit

Emission = Radiated Amplitude + Correct Factor

Correct Factor = Antenna Correction Factor + Cable Loss - Pre-Amplifier Gain

A margin of -8dB means that the emission is 8dB below the limit

Antenna Distance: 10 meters

Below 1GHz test, if the peak measured value meets the QP limit, it is unnecessary to perform the QP measurement.



Address: No. 120, Lane 180, Hsin Ho Rd., Lung-Tan Dist.,  
Tao Yuan City 325, Taiwan.  
Tel: 03-4071718

Radiated Emission Measurement  
Date: 2019/8/21

Operator: Juanwei  
Temperature: 26 °C  
Humidity: 60 %

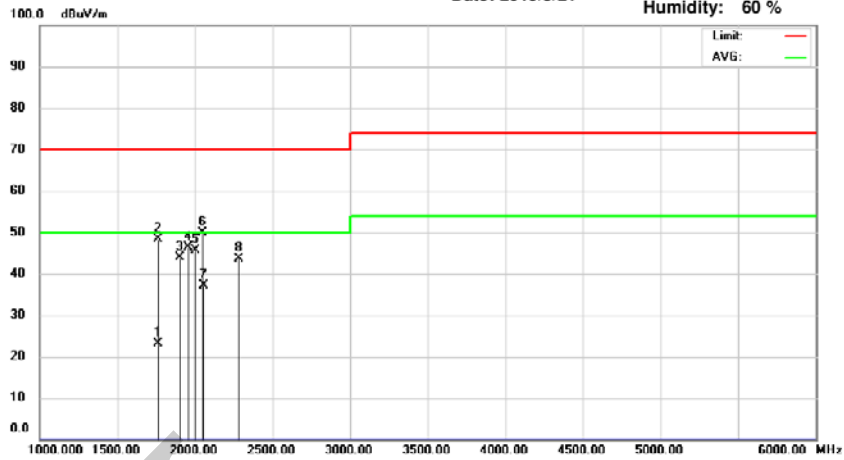

Site : Chamber 14

Polarization: Vertical

Mk.	Frequency (MHz)	RX_R (dBuV)	Correct Factor(dB/m)	Emission (dBuV/m)	Limit (dBuV/m)	Margin (dB)	Ant.Pos (cm)	Tab.Pos (deg.)	Detector
1	1755.43	37.63	-14.50	23.13	50.00	-26.87	143	360	AVG
2	1760.00	62.79	-14.44	48.35	70.00	-21.65	150	360	peak
3	1900.00	56.93	-13.01	43.92	70.00	-26.08	100	181	peak
4	1955.00	59.01	-12.58	46.43	70.00	-23.57	151	151	peak
5	2005.00	58.11	-12.56	45.55	70.00	-24.45	100	122	peak
6	2050.00	62.43	-12.53	49.90	70.00	-20.10	200	166	peak
7	2054.99	49.65	-12.54	37.11	50.00	-12.89	196	171	AVG
8	2280.00	56.01	-12.37	43.64	70.00	-26.36	151	179	peak

\* Note:

Margin = Emission - Limit

Emission = Radiated Amplitude + Correct Factor

Correct Factor = Antenna Correction Factor + Cable Loss - Pre-Amplifier Gain

A margin of -8dB means that the emission is 8dB below the limit

Antenna Distance: 3 meters

Above 1GHz test, if the peak measured value meets the average limit, it is unnecessary to perform the average measurement.

#### 4.4 Test Setup Photo

Front View (30MHz~1GHz)

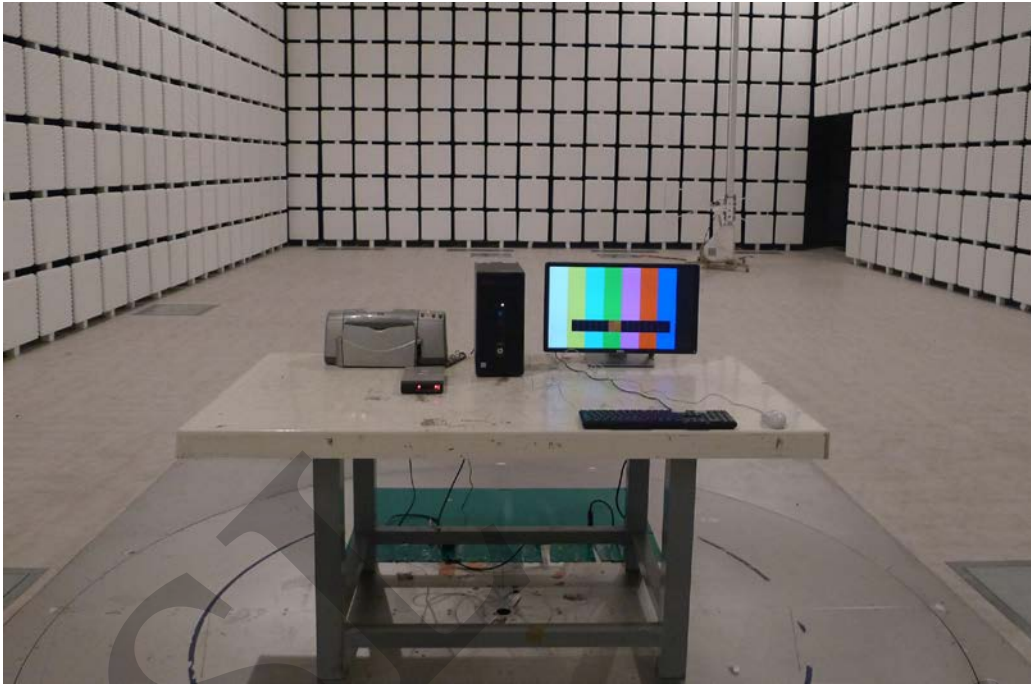

Back View (30MHz~1GHz)

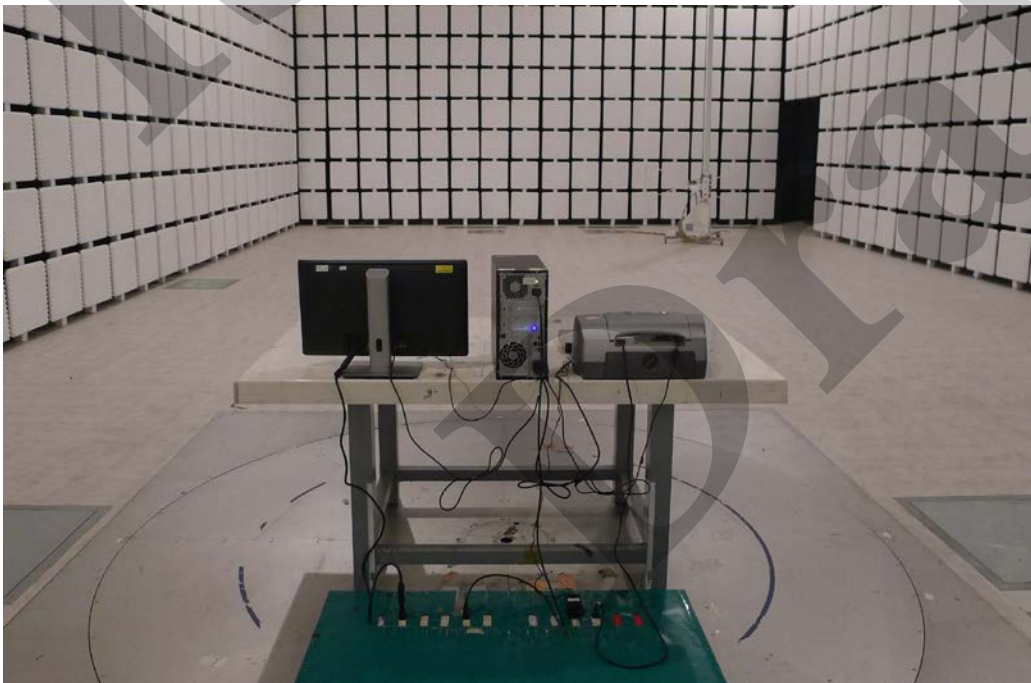

Front View (above 1GHz)

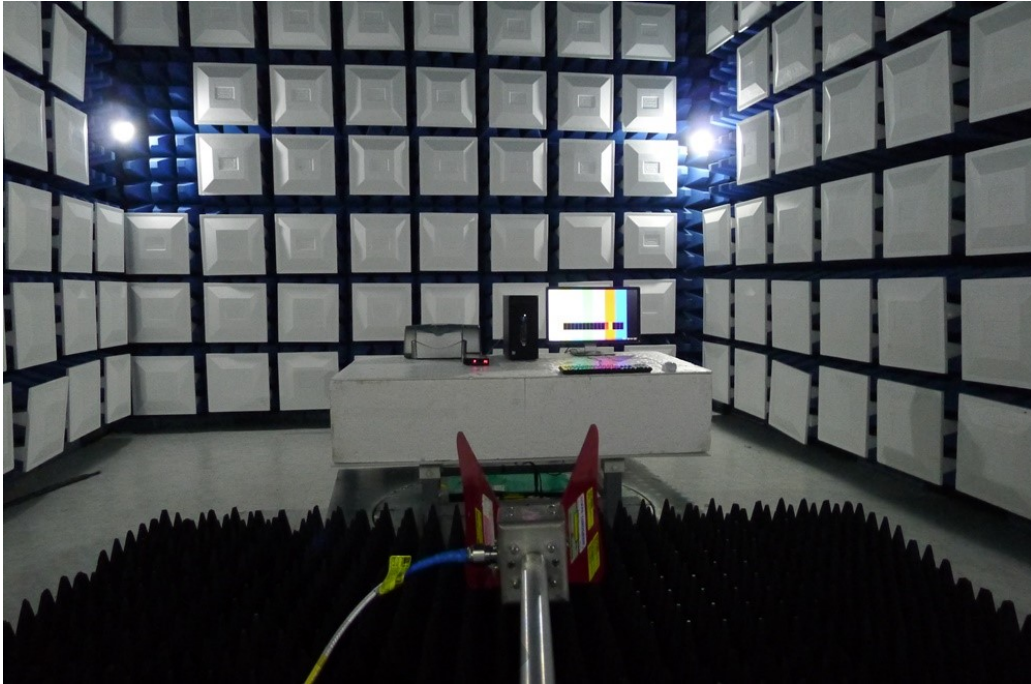

Back View (above 1GHz)

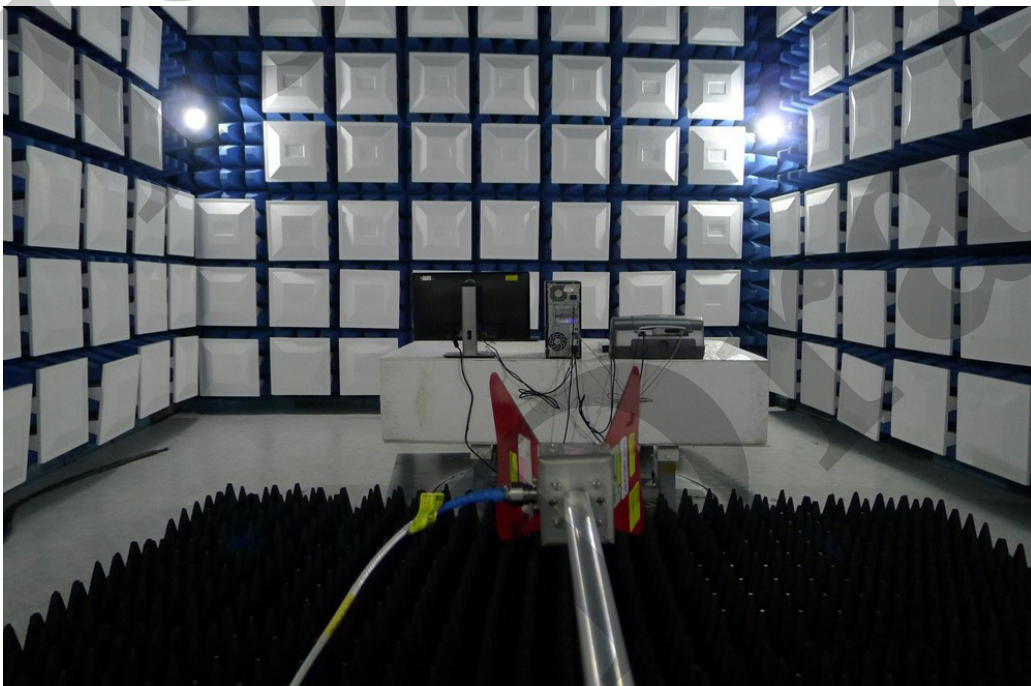

## 5. Voltage Disturbance Emissions at Antenna Terminals

### 5.1 Test Setup and Procedure

#### 5.1.1 Test Setup

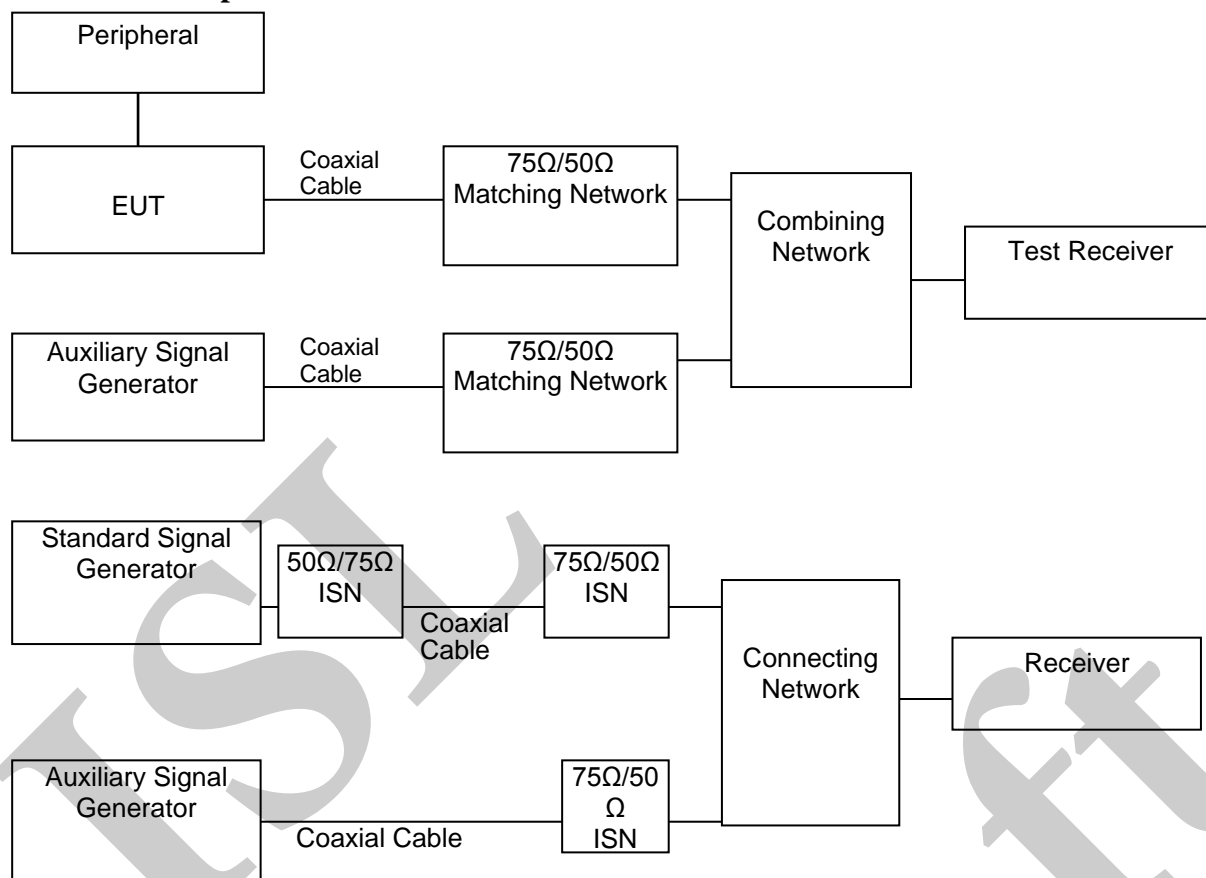

#### 5.1.2 Test Procedure

The output level of the auxiliary signal generator was set to 70dBuV at the EUT antenna terminal with 75 ohms impedance with an un-modulated carrier.

The highest emissions were analyzed in details by operating the spectrum analyzer and/or EMI receiver in quasi-peak mode to determine the precise amplitude of the emissions. The power of EUT was switched off to make sure the emission was not contributed by the auxiliary signal generator. While doing so, the interconnecting cables and major parts of the system were moved around to maximize the emission.

#### 5.1.3 EMI Receiver Configuration (for the frequencies tested)

Frequency Range:	30MHz-2150MHz
Detector Function:	Quasi-Peak Mode
Resolution Bandwidth:	120kHz

**5.1.4 Limit**

**Applicable to:**

- 1. TV broadcast receiver tuner ports with an accessible connector.**
- 2. RF modulator output ports.**
- 3. FM broadcast receiver tuner ports with an accessible connector.**

Table clause	Frequency range MHz	Detector type/ bandwidth	Class B limits dB(μV) 75 Ω			Applicability
			Other	Local Oscillator Fundamental	Local Oscillator Harmonics	
A12.1	30 – 950	For frequencies ≤1 GHz  Quasi Peak/ 120 kHz	46	46	46	See a)
	950 – 2 150		46	54	54	
A12.2	950 – 2 150		46	54	54	See b)
A12.3	30 – 300		46	54	50	See c)
	300 – 1 000	52				
A12.4	30 – 300	For frequencies ≥1 GHz	46	66	59	See d)
	300 – 1 000				52	
A12.5	30 – 950	Peak/ 1 MHz	46	76	46	See e)
	950 – 2 150			n/a	54	

a) Television receivers (analogue or digital), video recorders and PC TV broadcast receiver tuner cards working in channels between 30 MHz and 1 GHz, and digital audio receivers.

b) Tuner units (not the LNB) for satellite signal reception.

c) Frequency modulation audio receivers and PC tuner cards.

d) Frequency modulation car radios.

e) Applicable to EUTs with RF modulator output ports (for example DVD equipment, video recorders, camcorders and decoders etc.) designed to connect to TV broadcast receiver tuner ports.

**\*\*Remarks: It is not necessary to be tested on this item.**

## 6. Differential Voltage Emissions

### 6.1 Test Setup and Procedure

#### 6.1.1 Test Setup

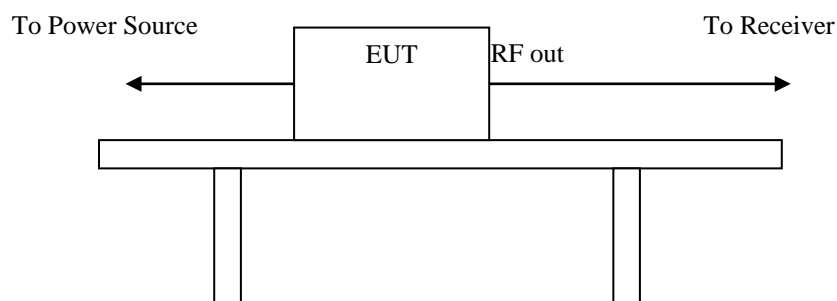

#### 6.1.2 Test Procedure

The output level of the auxiliary signal generator was set to 70dBuV at the EUT antenna terminal with 75 ohms impedance with an un-modulated carrier.

The highest emissions were analyzed in details by operating the spectrum analyzer and/or EMI receiver in quasi-peak mode to determine the precise amplitude of the emissions. The power of EUT was switched off to make sure the emission was not contributed by the auxiliary signal generator. While doing so, the interconnecting cables and major parts of the system were moved around to maximize the emission.

#### 6.1.3 EMI Receiver Configuration (for the frequencies tested)

Frequency Range:	30MHz-2150MHz
Detector Function:	Quasi-Peak Mode
Resolution Bandwidth:	120kHz

**6.1.4 Limit**

**Applicable to:**

- 1. TV broadcast receiver tuner ports with an accessible connector.**
- 2. RF modulator output ports.**
- 3. FM broadcast receiver tuner ports with an accessible connector.**

Table clause	Frequency range MHz	Detector type/ bandwidth	Class B limits dB(μV) 75 Ω			Applicability
			Other	Local Oscillator Fundamental	Local Oscillator Harmonics	
A12.1	30 – 950	For frequencies ≤1 GHz  Quasi Peak/ 120 kHz	46	46	46	See a)
	950 – 2 150		46	54	54	
A12.2	950 – 2 150		46	54	54	See b)
A12.3	30 – 300		For frequencies ≥1 GHz	46	54	50
	300 – 1 000	52				
A12.4	30 – 300	Peak/ 1 MHz	46	66	59	See d)
	300 – 1 000				52	
A12.5	30 – 950	Peak/ 1 MHz	46	76	46	See e)
	950 – 2 150			n/a	54	

a) Television receivers (analogue or digital), video recorders and PC TV broadcast receiver tuner cards working in channels between 30 MHz and 1 GHz, and digital audio receivers.

b) Tuner units (not the LNB) for satellite signal reception.

c) Frequency modulation audio receivers and PC tuner cards.

d) Frequency modulation car radios.

e) Applicable to EUTs with RF modulator output ports (for example DVD equipment, video recorders, camcorders and decoders etc.) designed to connect to TV broadcast receiver tuner ports.

**\*\*Remarks: It is not necessary to be tested on this item.**

## 7. Outdoor units of home satellite receiving systems

### 7.1 Test Setup and Procedure

#### 7.1.1 Test Setup

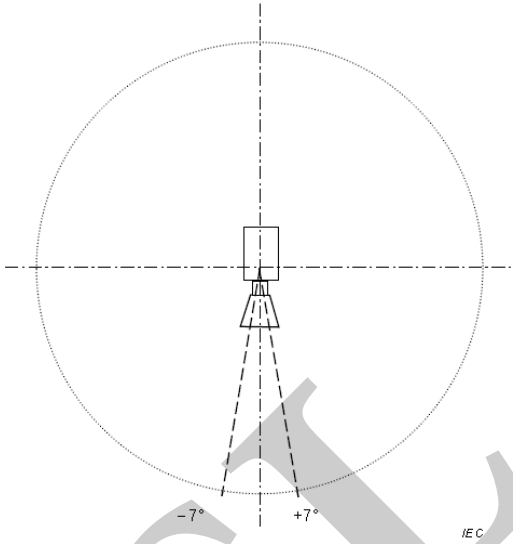
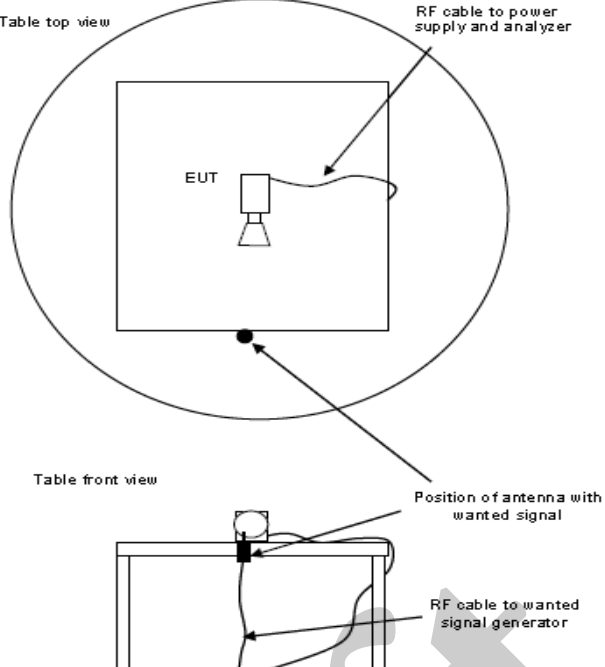
	
Description of $\pm 7^\circ$ of the main beam axis of the EUT	Measurement arrangements of transmit antenna for the wanted signal

#### 7.1.2 Test Procedure

The input signal shall be adjusted to get the maximum rated output level from the EUT. For the measurement in the frequency range from 30 MHz to 18 GHz the input signal shall be adjusted so that the output frequency is within this frequency range. For the measurement in the frequency range above 1 GHz, the frequency of the input signal shall be adjusted in such a way that the EUT is measured, as a minimum, at the lowest, middle and highest rated output frequency within the measured frequency range.

#### 7.1.3 Spectrum Analyzer Configuration (for the frequencies tested)

Frequency Range: 30MHz--1000MHz  
 Detector Function: Quasi-Peak Mode  
 Resolution Bandwidth: 120kHz

Frequency Range: Above 1000MHz  
 Detector Function: Peak/Average Mode  
 Resolution Bandwidth: 1MHz

### 7.1.4 Limit

Table Clause	Frequency Range MHz	Measurement			Class B Limits	Applicable to
		Facility (see Table A.1)	Distance m	Detector type / Bandwidth		
A7.1	30 to 1 000	SAC / OATS / FAR	See Table A.4	Quasi Peak / 120 kHz	See Table A.4	
A7.2	1 000 to 2 500	FSOATS	3	Average / 1 MHz	50 dB( $\mu$ V/m)	LO leakage and spurious radiated emissions from the EUT, in the region outside $\pm 7^\circ$ of the main beam axis. See Figure H.1
	2 500 to 18 000				64 dB( $\mu$ V/m)	
A7.3	1 000 to 18 000	FSOATS	3	Average / 1 MHz	37 dB( $\mu$ V/m)	LO leakage from the EUT, in the region within $\pm 7^\circ$ of the main beam axis. See Figure H.1
A7.4	1 000 to 18 000	Conducted (Clause H.4)	n/a	Average / 1 MHz	30 dBpW	

For details of the EUT configuration, see Annex H.

For radiated emissions measurements at frequencies up to 1 GHz, the requirements defined in Table A.4 shall be satisfied.

Apply the appropriate limits across the entire frequency range.

Apply the limits defined in table Clause A7.1 and A7.2. Also apply the limits defined in either table Clause A7.3 or A7.4.

**\*\*Remarks: It is not necessary to be tested on this item.**

## 8. Electrostatic discharge (ESD) immunity

### 8.1 Test Specification and Setup

#### 8.1.1 Test Specification

Port:	Enclosure
Basic Standard:	EN 61000-4-2/ IEC 61000-4-2 (details referred to Sec 1.2)
Test Level:	Air +/- 2 kV, +/- 4 kV, +/- 8 kV Contact +/- 4 kV
Criteria:	B
Test Procedure	refer to ISL QA -T4-E-S7
Temperature:	24 °C
Humidity:	40 %

#### Selected Test Point

**Air:** discharges were applied to slots, aperture or insulating surfaces. 10 single air discharges were applied to each selected points.

**Contact:** Total 200 discharges minimum were to the selected contact points.

**Indirect Contact Points:** 25 discharges were applied to center of one edge of VCP and each EUT side of HCP with 10 cm away from EUT.

#### 8.1.2 Test Setup

EUT is 1m from the wall and other metallic structure. When Battery test mode is needed, a cable with one 470K $\Omega$  resistor at two rare ends is connected from metallic part of EUT and screwed to HCP.

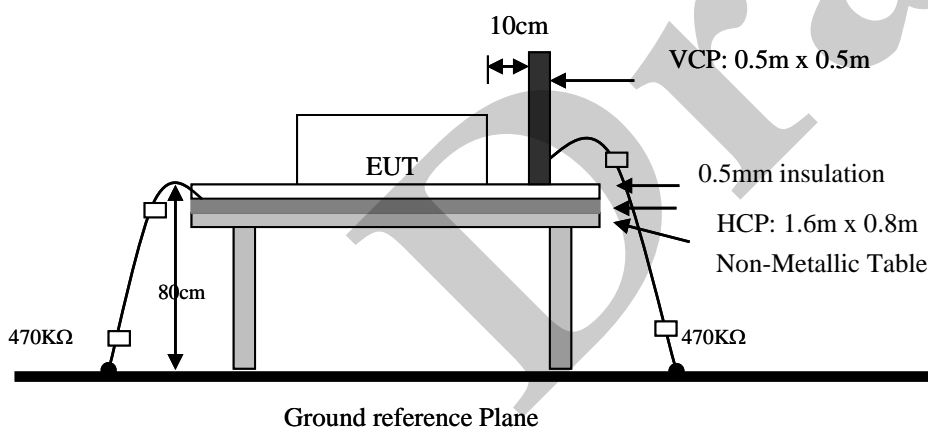

#### 8.1.3 Test Result

**Performance of EUT complies with the given specification**

## 8.2 Test Point

Red arrow lines indicate the contact points, and blue arrow lines indicate the air points.

Figure 1: Test Point Assignments Discharge:



### 8.3 Test Setup Photo

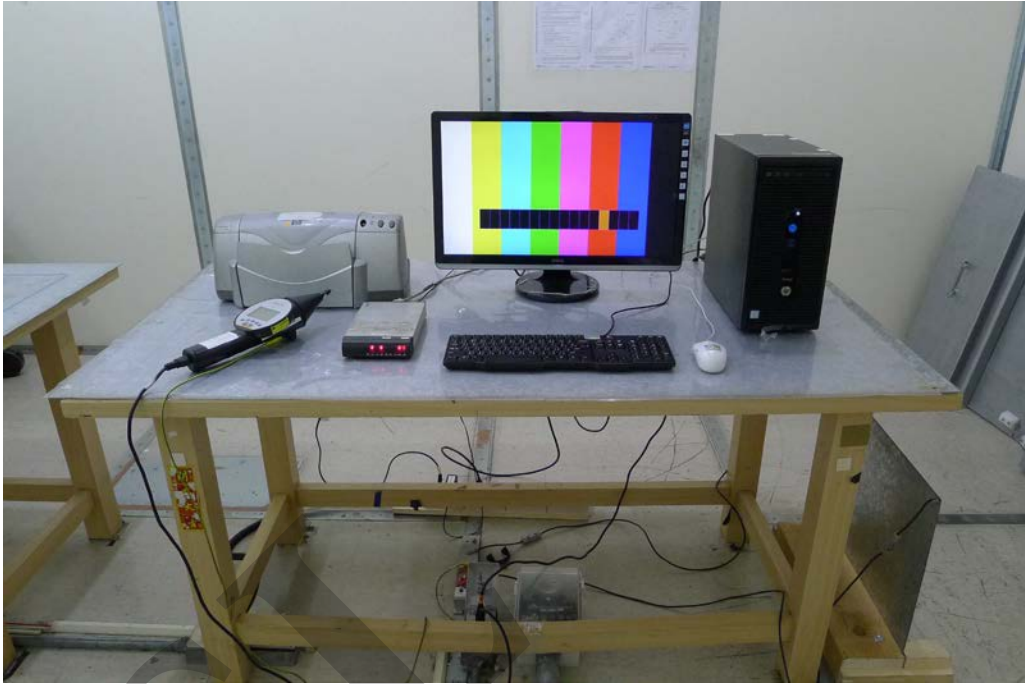

ISL  
Draft

## 9. Radio-Frequency, Electromagnetic Field immunity

### 9.1 Test Specification and Setup

#### 9.1.1 Test Specification

Port:	Enclosure
Basic Standard:	EN 61000-4-3/ IEC 61000-4-3 (details referred to Sec 1.2)
Test Level:	3 V/m
Modulation:	AM 1kHz 80%
Frequency range:	80 MHz~1 GHz
Frequency Step:	1% of last step frequency
Dwell time:	3s
Polarization:	Vertical and Horizontal
EUT Azimuth Angle	☒0° ☒90° ☒180° ☒270°
Criteria:	A
Test Procedure	refer to ISL QA -T4-E-S8
Temperature:	24 °C
Humidity:	53 %

#### 9.1.2 Test Setup

The field sensor is placed at one calibration grid point to check the intensity of the established fields on both polarizations. EUT is adjusted to have each side of EUT face coincident with the calibration plane. A CCD camera and speakers are used to monitor the condition of EUT for the performance judgment.

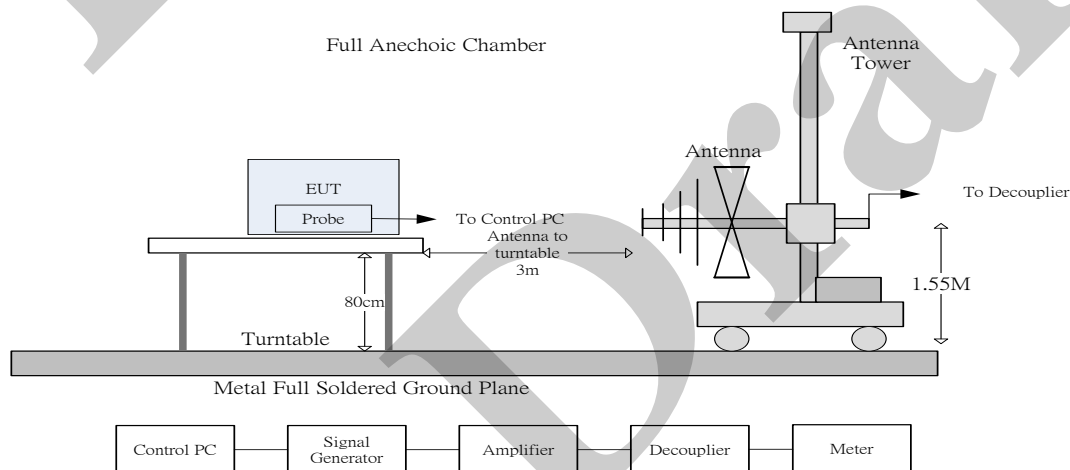

#### 9.1.3 Test Result

**Performance of EUT complies with the given specification**

## 9.2 Test Setup Photo

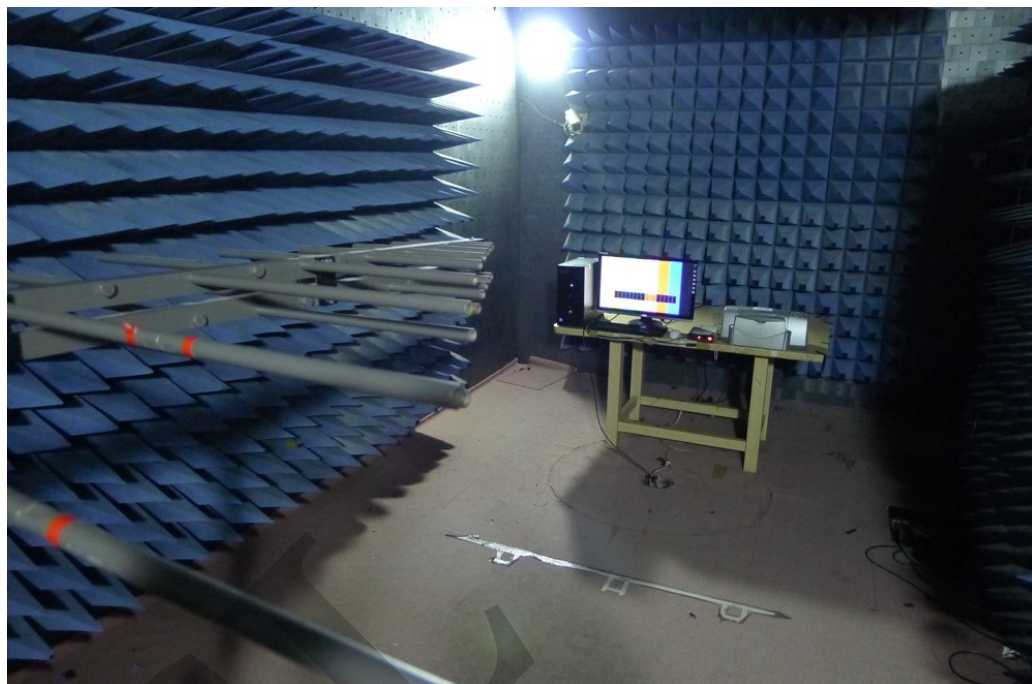

## 10. Electrical Fast transients/burst immunity

### 10.1 Test Specification and Setup

#### 10.1.1 Test Specification

Port:	AC mains
Basic Standard:	EN 61000-4-4/ IEC 61000-4-4 (details referred to Sec 1.2)
Test Level:	AC Power Port: +/- 1 kV
Rise Time:	5ns
Hold Time:	50ns
Burst Period:	300ms
Repetition Frequency:	5kHz
Criteria:	B
Test Procedure	refer to ISL QA -T4-E-S9
Temperature:	24 °C
Humidity:	52 %

#### Test Procedure

The EUT was setup on a nonconductive table 0.1 m above a reference ground plane.

Test Points	Polarity	Result	Comment
Line	+	N	60 sec
	-	N	60 sec
Neutral	+	N	60 sec
	-	N	60 sec
Ground	+	N	60 sec
	-	N	60 sec
Line to Neutral	+	N	60 sec
	-	N	60 sec
Line to Ground	+	N	60 sec
	-	N	60 sec
Neutral to Ground	+	N	60 sec
	-	N	60 sec
Line to Neutral to Ground	+	N	60 sec
	-	N	60 sec
Capacitive coupling clamp	+	N	60 sec
	-	N	60 sec

Note: 'N' means normal, the EUT function is correct during the test.

### 10.1.2 Test Setup

EUT is at least 50cm from the conductive structure.

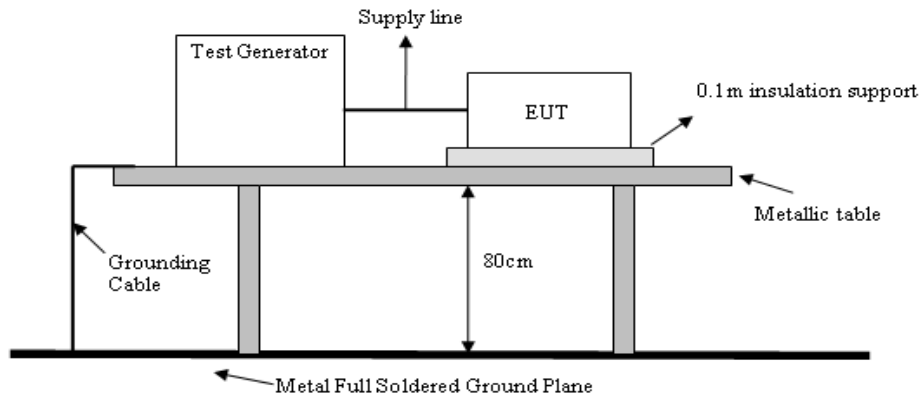

### 10.1.3 Test Result

Performance of EUT complies with the given specification

## 10.2 Test Setup Photo



ISL  
Draft

## 11. Surge Immunity

### 11.1 Test Specification and Setup

#### 11.1.1 Test Specification

Port:	AC mains
Basic Standard:	EN 61000-4-5/ IEC 61000-4-5 (details referred to Sec 1.2)
Test Level:	Line to Line: +/- 0.5 kV, +/- 1 kV Line to Earth: +/- 0.5 kV, +/- 1 kV, +/- 2kV
Rise Time:	1.2us
Hold Time:	50us
Repetition Rate:	30 seconds
Angle:	<input checked="" type="checkbox"/> 0° <input checked="" type="checkbox"/> 90° <input checked="" type="checkbox"/> 180° <input checked="" type="checkbox"/> 270°
Criteria:	B
Remarks:	
Test Procedure:	refer to ISL QA -T4-E-S10
Temperature:	24 °C
Humidity:	51 %

#### 11.1.2 Test Setup

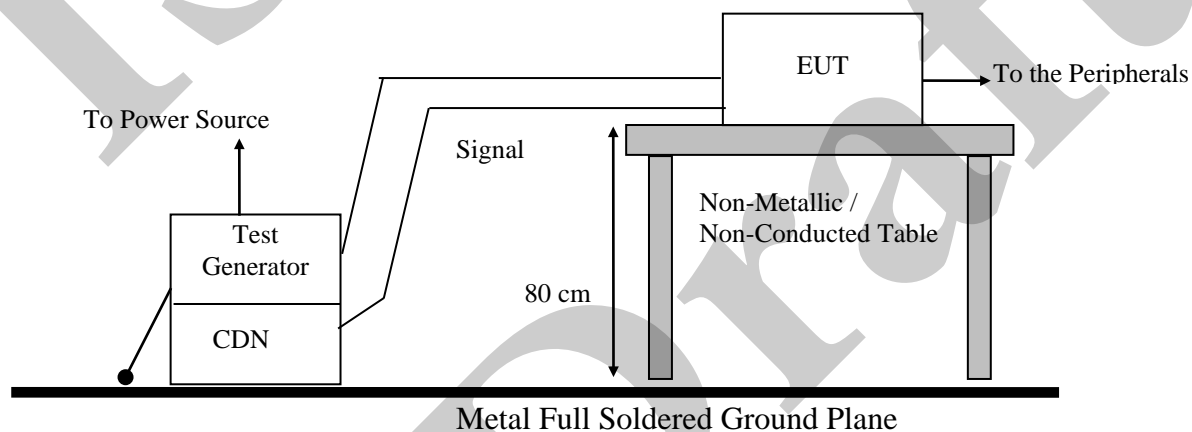

#### 11.1.3 Test Result

Performance of EUT complies with the given specification

## 11.2 Test Setup Photo



## 12. Immunity to Conductive Disturbance

### 12.1 Test Specification and Setup

#### 12.1.1 Test Specification

Port:	AC mains;
Basic Standard:	EN 61000-4-6/ IEC 61000-4-6 (details referred to Sec 1.2)
Test Level:	3 V
Modulation:	AM 1kHz 80%
Frequency range:	0.15 MHz - 80MHz
Frequency Step:	1% of last Frequency
Dwell time:	3s
Criteria:	A
CDN Type:	CDN M2+M3
Test Procedure	refer to ISL QA -T4-E-S11
Temperature:	23°C
Humidity:	52%

#### 12.1.2 Test Setup

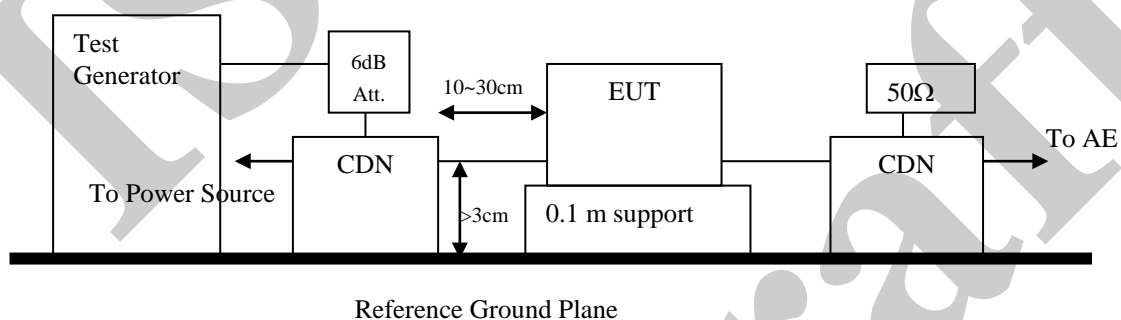

#### 12.1.3 Test Result

Performance of EUT complies with the given specification

## 12.2 Test Setup Photo



## 13. Power Frequency Magnetic Field immunity

### 13.1 Test Specification and Setup

#### 13.1.1 Test Specification

Port:	Enclosure
Basic Standard:	EN 61000-4-8/ IEC 61000-4-8 (details referred to Sec 1.2)
Test Level:	1A/m
Polarization:	X, Y, Z
Criteria:	A
Test Procedure	refer to ISL QA -T4-E-S12
Temperature:	23°C
Humidity:	51%

#### 13.1.2 Test Setup

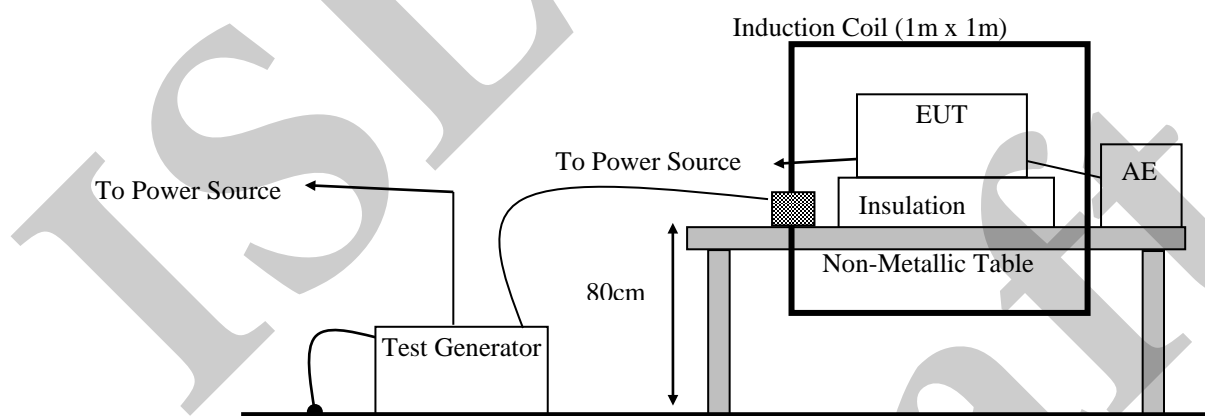

#### 13.1.3 Test Result

**Performance of EUT complies with the given specification**

### 13.2 Test Setup Photo



ISL  
Draft

## 14. Voltage Dips, Short Interruption and Voltage Variation immunity

### 14.1 Test Specification and Setup

#### 14.1.1 Test Specification

Port:	AC mains
Basic Standard:	EN 61000-4-11/ IEC 61000-4-11 (details referred to Sec 1.2)
Test Level: Criteria:	>95% in 0.5 period B
Test Level: Criteria:	30% in 25 period C
Test Level: Criteria:	>95% in 250 period C
Phase:	0°; 180°
Test intervals:	3 times with 10s each
Test Procedure	refer to ISL QA -T4-E-S13
Temperature:	23°C
Humidity:	52%

#### 14.1.2 Test Setup

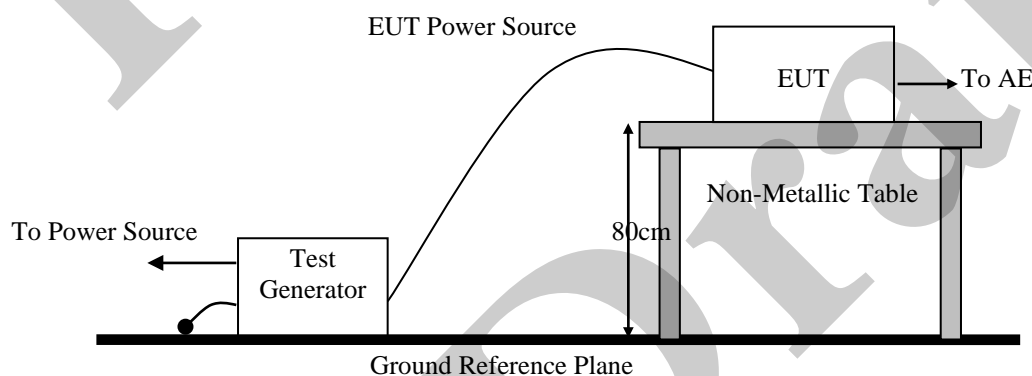

#### 14.1.3 Test Result

Performance of EUT complies with the given specification

## 14.2 Test Setup Photo



## 15. Harmonics

### 15.1 Test Specification and Setup

#### 15.1.1 Test Specification

Port:	AC mains
Active Input Power:	<75W
Basic Standard:	EN 61000-3-2/IEC 61000-3-2 (details referred to Sec 1.2)
Test Duration:	2.5min
Class:	A
Test Procedure	refer to ISL QA -T4-E-S14
Temperature:	23°C
Humidity:	52%

#### Test Procedure

The EUT is supplied in series with shunts or current transformers from a source having the same nominal voltage and frequency as the rated supply voltage and frequency of the EUT. The EUT is configured to its rated current with additional resistive load when the testing is performed.

Equipment having more than one rated voltage shall be tested at the rated voltage producing the highest harmonics as compared with the limits.

#### 15.1.2 Test Setup

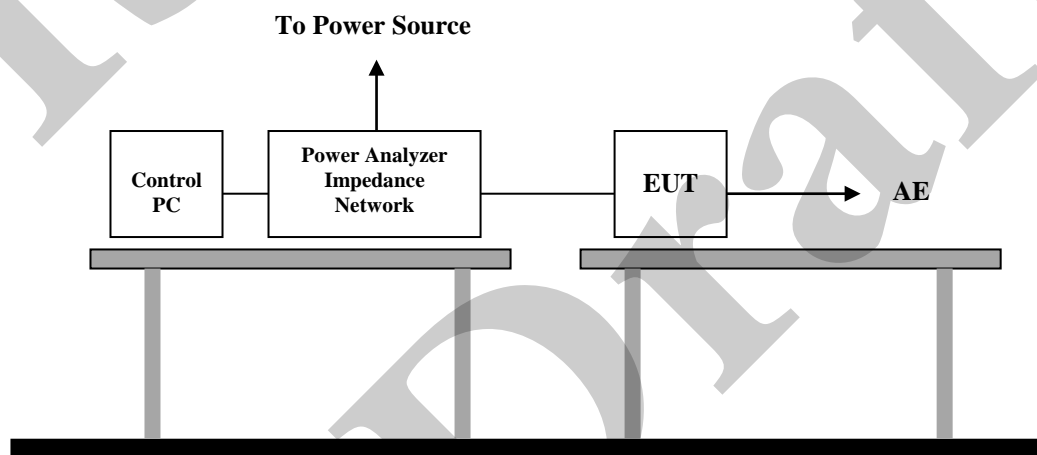

### 15.1.3 Limit

#### Limits of Class A Harmonics Currents

Harmonics Order n	Maximum Permissible harmonic current A	Harmonics Order n	Maximum Permissible harmonic current A
Odd harmonics		Even harmonics	
3	2.30	2	1.08
5	1.14	4	0.43
7	0.77	6	0.30
9	0.40	$8 \leq n \leq 40$	$0.23 * 8/n$
11	0.33		
13	0.21		
$15 \leq n \leq 39$	$0.15 * 15/n$		

### 15.1.4 Test Result

Active input power under 75W, no limit apply, declare compliance

## 16. Voltage Fluctuations

### 16.1 Test Specification and Setup

#### 16.1.1 Test Specification

Port:	AC mains
Basic Standard:	EN 61000-3-3/IEC61000-3-3 (details referred to Sec 1.2)
Test Procedure	refer to ISL QA -T4-E-S14
Observation period:	For Pst 10min
	For Plt 2 hours
Temperature:	23°C
Humidity:	52%

#### Test Procedure

The EUT is supplied in series with reference impedance from a power source with the voltage and frequency as the nominal supply voltage and frequency of the EUT.

#### 16.1.2 Test Setup

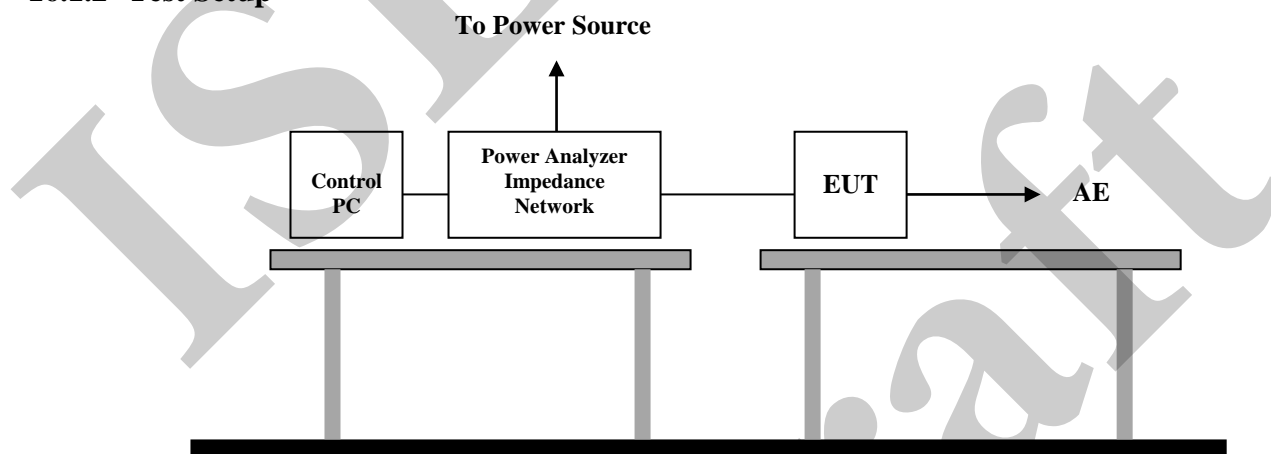

#### 16.1.3 Test Result

**Performance of EUT complies with the given specification.**

### 16.2 Test Data

#### Flicker Test Summary per EN/IEC61000-3-3 Ed. 3.0 (2013) (Run time)

Test category: All parameters (European limits)      Test Margin: 100  
 Test duration (min): 10      Data file name: CTSMXL\_F-001164.cts\_data

Test Result: Pass      Status: Test Completed

**Pst<sub>i</sub> and limit line** **European Limits**



**Plt and limit line**

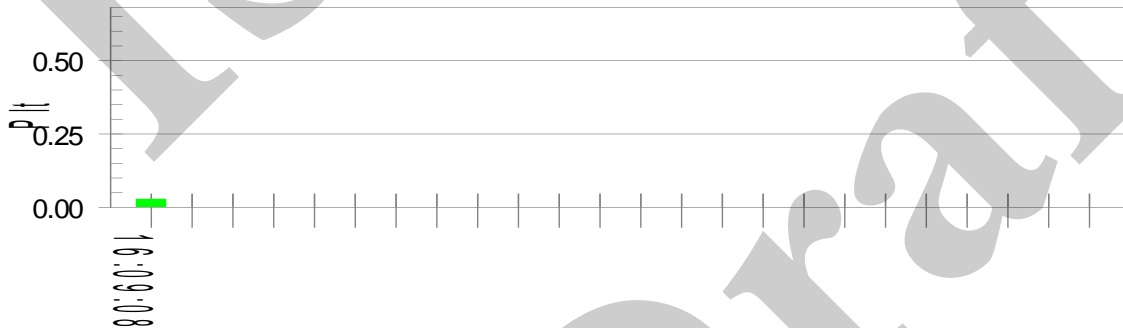

**Parameter values recorded during the test:**

Vrms at the end of test (Volt):	229.65			
T-max (mS):	0.0	Test limit (mS):	500.0	Pass
Highest dc (%):	0.00	Test limit (%):	3.30	Pass
Highest dmax (%):	0.06	Test limit (%):	4.00	Pass
Highest Pst (10 min. period):	0.064	Test limit:	1.000	Pass
Highest Plt (2 hr. period):	0.028	Test limit:	0.650	Pass

### 16.3 Test Setup Photo



## 17. Appendix

### 17.1 Appendix A: Test Equipment

#### 17.1.1 Test Equipment List

Location Con02	Equipment Name	Brand	Model	S/N	Last Cal. Date	Next Cal. Date
Conduction 02	LISN 26	R&S	ENV216	102378	11/21/2018	11/21/2019
Conduction 02	LISN 23	R&S	ENV216	101477	07/31/2019	07/31/2020
Conduction 02	Conduction 02-1 Cable	WOKEN	CFD 300-NL	Conduction 02 -1	08/23/2019	08/23/2020
Conduction 02	EMI Receiver 14	ROHDE& SCHWARZ	ESCI	101034	05/31/2019	05/31/2020

Location Chamber02	Equipment Name	Brand	Model	S/N	Last Cal. Date	Next Cal. Date
Radiation (Chamber02)	BILOG Antenna 17	Schwarzbeck	Schwarzbeck VULB 9168+EMCI-N -6-05	645	03/06/2019	03/06/2020
Radiation (Chamber02)	Preamplifier 25	EMCI	EMC9135	980295	02/27/2019	02/27/2020
Radiation (Chamber02)	Coaxial Cable Chmb 02-10M-02	EMC	RG214U	Chmb 02-10M-02	08/23/2019	08/23/2020
Radiation (Chamber02)	EMI Receiver 12	ROHDE & SCHWARZ	ESCI	100804	08/14/2019	08/14/2020

Location Chmb14	Equipment Name	Brand	Model	S/N	Last Cal. Date	Next Cal. Date
Rad. Above 1GHz	Spectrum Analyzer 25	R&S	FSV 40	101499	11/03/2018	11/03/2019
Rad. Above 1GHz	Spectrum Analyzer 24 (1G~26.5GHz)	Agilent	N9010A	MY49060537	08/29/2018	08/29/2019
Rad. Above 1GHz	Horn Antenna 06	ETS-Lindgren	3117	00066665	10/31/2018	10/31/2019
Rad. Above 1GHz	Preamplifier 13	MITEQ	JS44-0010180 0-25-10P-44	1329256	11/21/2018	11/21/2019
Rad. Above 1GHz	Microwave Cable 35	WOKEN	WCBA-WCA0 4NM.SM6	Chamber 14-1	01/31/2019	01/31/2020
Rad. Above 1GHz	Microwave Cable 36	WOKEN	WCBA-WCA0 4NM.SM0.8	Chamber 14-2	01/31/2019	01/31/2020

Location	Equipment Name	Brand	Model	S/N	Last Cal. Date	Next Cal. Date
EN61K-4-2	ESD Gun 12	EM TEST	Dito	P1650188689	05/07/2019	05/07/2020
EN61K-4-3	Broadband Log-Periodic Antenna	AR	AT1080	310698	N/A	N/A
EN61K-4-3	Horn Antenna RF-01	AR	ATS700M11 G	0335864	N/A	N/A
EN61K-4-3	Amplifier 80Mz~1GHz 250W	AR	250W1000A	312494	N/A	N/A
EN61K-4-3	Amplifier 800MHz~4.2GHz 50W	AR	50S1G4M1	312762	N/A	N/A
EN61K-4-3	Amplifier 4.0~8.0GHz 35W	AR	35S4G8AM1	0335752	N/A	N/A
EN61K-4-3	Broadband Coupler 80M~1GHz	Amplifier Research	DC6180A	0341805	N/A	N/A
EN61K-4-3	Coaxial Cable	INSULATED	NPS-4806-23 60-NP3	108599.003.01.03	N/A	N/A
EN61K-4-3	Broadband Coupler 0.8G~4.26GHz	AR	DC7144A	0335226	N/A	N/A
EN61K-4-3	Broadband Coupler 4G~8GHz	AR	DC7350A	0335817	N/A	N/A
EN61K-4-3	Signal Generator 07	ROHDE& SCHWARZ	SMB100A	107780	10/28/2018	10/28/2019
EN61K-4-4	EFT and SURGE Test System	EM TEST	UCS-500 M6B	V0728102674	02/14/2019	02/14/2020
EN61K-4-4	Capacitive Coupling Clamp	EM TEST	HFK	0907-106	02/14/2019	02/14/2020
EN61K-4-5	CDN-UTP8 ED3	EMC-PARTNER	CDN-UTP8	1509	04/02/2019	04/02/2020
EN61K-4-5	SURGE-TESTER	EMC Partner	MIG0603IN3	523	04/02/2019	04/02/2020
EN61K-4-6	CDN M2+M3 05	Frankonia	CDN M2+M3	A2210235/2013	09/22/2018	09/22/2019
EN61K-4-6	CDN T2 04	FCC Inc.	FCC-801-T2	02067	08/14/2019	08/14/2020
EN61K-4-6	CDN T4 06	FCC Inc.	FCC-801-T4	02068	06/24/2019	06/24/2020
EN61K-4-6	CDN T8-10_2	Teseq GmbH	CDN T8 10	41241	03/26/2019	03/26/2020
EN61K-4-6	Coaxial Cable 4-6 02-1			4-6 02-1	N/A	N/A
EN61K-4-6	Conducted Immunity Test System 02	Frankonia	CIT-10-75-D C	126B1301/2014	03/25/2019	03/25/2020
EN61K-4-6	EM-Clamp	Schaffner	KEMZ-801	19215	11/08/2018	11/08/2019
EN61K-4-8	Magnetic Field Immunity Loop	FCC	F-1000-4-8-L-1M	01037	05/27/2019	06/05/2020
EN61K-4-8	Magnetic Field Test Generator	FCC	F-1000-4-8-G-125A	01038	05/27/2019	06/05/2020
EN61K-4-11	Voltage Dip and UP Simulator	NoiseKen	VDS-2002	VDS0640162	11/06/2018	11/06/2019
EN61K-3-2/3, EN61K-3-11-1 2	(Harmonic/Flicker) MX Series CTSB Compliance Test System	California Instruments	MX60T04GH 10400	72793	08/05/2019	08/05/2020

PS: N/A => The equipment does not need calibration.

**\*\*Software for Controlling Spectrum/Receiver and Calculating Test Data**

Test Item	Filename	Version
EN61000-3-2	California Instruments	CTSMXL V2.19.0
EN61000-3-3	California Instruments	CTSMXL V2.19.0
EN61000-4-2	N/A	2.0
EN61000-4-3	i2	4.130102k
EN61000-4-4	EMC TEST	4.10
EN61000-4-5	EMC Partner	1.69
EN61000-4-6	FRANKONIA CD-LAB	V5.221
EN61000-4-8	N/A	
EN61000-4-11	NOISE KEN	2.0

Site	Filename	Version	Issue Date
Conduction/Radiation	EZ EMC	ISL-03A2	3/6/2013

## 17.2 Appendix B: Uncertainty of Measurement

The laboratory measurement uncertainty accordance with refers to CISPR 16-4-2. If  $U_{lab}$  is less than or equal to  $U_{Cispr}$  in Table 1, then the test report may either state the value of  $U_{lab}$  or state that  $U_{lab}$  is less than  $U_{Cispr}$ .

The coverage factor  $k = 2$  yields approximately a 95 % level of confidence.

<Conduction 02>

AMN:  $\pm 2.90\text{dB}$

ISN T2:  $\pm 3.04\text{dB}$

ISN T4:  $\pm 3.05\text{dB}$

ISN T8:  $\pm 3.05\text{dB}$

CVP:  $\pm 3.62\text{dB}$

CP:  $\pm 2.88\text{dB}$

<Chamber 02 (10M)>

Horizontal

30MHz~200MHz:  $\pm 4.69\text{dB}$

200MHz~1000MHz:  $\pm 4.30\text{dB}$

Vertical

30MHz~200MHz:  $\pm 4.65\text{dB}$

200MHz~1000MHz:  $\pm 4.35\text{dB}$

<Chamber 14 (3M)>

1GHz~6GHz:  $\pm 5.12\text{dB}$

1GHz~18GHz:  $\pm 4.66\text{dB}$

18GHz~26.5GHz:  $\pm 4.48\text{dB}$

26.5GHz~40GHz:  $\pm 4.58\text{dB}$

## &lt;Immunity 02&gt;

Test item	Uncertainty	Test item	Uncertainty
EN 61000-4-2 (ESD)		EN 61000-4-6 (CS)	
Rise time tr	$\leq 15\%$	CDN	$\pm 1.36\text{dB}$
Peak current Ip	$\leq 6.3\%$	EM Clamp	$\pm 3.19\text{dB}$
current at 30 ns	$\leq 6.3\%$	EN 61000-4-8 (Magnetic)	$\pm 6.55\%$
current at 60 ns	$\leq 6.3\%$	EN 61000-4-11 (Dips)	
EN 61000-4-3 (RS)	$\pm 2.19\text{dB}$	Time	$\pm 2.80\%$
EN 61000-4-4 (EFT)		Voltage	$\pm 1.5\%$
voltage rise time (tr)	$\pm 6.2\%$	EN 61000-3-2 (Harmonics)	$\pm 5.1\%$
peak voltage value (VP)	$\pm 8.6\%$	EN 61000-3-3 (Fluctuations and Flicker)	$\pm 5.1\%$
voltage pulse width (tw)	$\pm 5.9\%$	EN 61000-3-12 (Harmonics)	$\pm 1\%$
EN 61000-4-5 (Surge)		EN 61000-3-11 (Fluctuations and Flicker)	$\pm 8\%$
open-circuit voltage front time	$\pm 1.2\mu\text{s}$	EN 61000-4-34 (Dips)	
open-circuit voltage peak value	$\pm 8.6\%$	Time	$\pm 2.80\%$
open-circuit voltage duration (Td)	$\pm 50.7\mu\text{s}$	Voltage	$\pm 1.70\%$
EN 61000-4-9 (Pulse magnetic field)		IEC 61000-4-17 (Ripple)	
Time	$\pm 2.80\%$	Voltage	$\pm 17\mu\text{V/V}$
Voltage	$\pm 5.5\%$	Current	$\pm 0.83\text{mA/A}$
Current	$\pm 3.3\%$	IEC 61000-4-18 (Damped oscillatory wave)	
IEC 61000-4-16 (conducted, common mode)		Time	$\pm 2.80\%$
Time	$\pm 2.80\%$	Voltage	$\pm 5.5\%$
Voltage	$\pm 5.5\%$	Current	$\pm 4.5\%$
Current	$\pm 3.3\%$	IEC 61000-4-29 (Voltage dips on d.c)	
Resistor	$\pm 0.03\text{m}\Omega/\Omega$	Voltage	$\pm 17\mu\text{V/V}$
Capacitor	$\pm 24\mu\text{F/F}$	Current	$\pm 0.83\text{mA/A}$

### 17.3 Appendix C: Photographs of EUT

Please refer to the File of **ISL-19LE512P-MA**

ISL  
Draft