

# TEST REPORT

of

## CFR 47 Part 15 Subpart B Class B & Industry Canada Interference-Causing Equipment Standard ICES-003 Class B

Application Type: Supplier's Declaration of Conformity

Product: **PCIe M.2 2280**  
Main Model: **PX180-M280 (X=A~Z)**  
Brand: **Apacer**  
Applicant: **Apacer Technology Inc.**  
Address: **1F., No.32, Zhongcheng Rd., Tucheng Dist.,  
New Taipei City 236, Taiwan , R.O.C.**

Test Performed by:

 **International Standards Laboratory Corp. LT Lab.**

TEL: +886-3-263-8888 FAX: +886-3-263-8899

 No. 120, Lane 180, Hsin Ho Rd., Lung-Tan Dist., Tao Yuan City 325, Taiwan

Report No.: **ISL-22LE0534FCCIC-MF**  
Issue Date : **December 27, 2022**



Test results given in this report apply only to the specific sample(s) tested and are traceable to national or international standard through calibration of the equipment and evaluating measurement uncertainty herein. The uncertainty of the measurement does not include in consideration of the test result unless the customer required the determination of uncertainty via the agreement, regulation or standard document specification. This test report shall not be reproduced except in full, without the written approval of International Standards Laboratory Corp.

## Contents of Report

1.	General .....	1
1.1	Certification of Accuracy of Test Data .....	1
1.2	Description of EUT .....	2
1.3	Description of Support Equipment .....	3
1.4	Software for Controlling Support Unit.....	4
1.5	I/O Cable Condition of EUT and Support Units .....	5
2.	Power Line Conducted Emissions.....	6
2.1	Test Setup and Procedure .....	6
2.1.1	Test Setup .....	6
2.1.2	Test Procedure .....	6
2.1.3	EMI Receiver/Spectrum Analyzer Configuration (for the frequencies tested).....	6
2.1.4	Limit .....	7
2.2	Conduction Test Data: Configuration 1 .....	8
2.3	Test Setup Photo.....	10
3.	Radiated Emissions .....	12
3.1	Test Setup and Procedure .....	12
3.1.1	Test Setup .....	12
3.1.2	Test Procedure .....	14
3.1.3	Spectrum Analyzer Configuration (for the frequencies tested) .....	14
3.1.4	Limit .....	15
3.2	Radiation Test Data: Configuration 1.....	16
3.3	Test Setup Photo.....	18
4.	Appendix .....	19
4.1	Appendix A: (FCC)Warning Labels.....	19
4.2	Appendix B: (FCC)Warning Statement .....	20
4.3	Appendix C: (Canada ISED) Labelling and user manual requirements.....	21
4.4	Appendix D: Test Equipment .....	22
4.4.1	Test Equipment List.....	22
4.4.2	Software for Controlling Spectrum/Receiver and Calculating Test Data.....	22
4.5	Appendix E: Uncertainty of Measurement.....	23
4.6	Appendix F: Photographs of EUT .....	24

# 1. General

## 1.1 Certification of Accuracy of Test Data

**Standards:** FCC CFR Title 47 Part 15 Subpart B: Section 15.107 and 15.109  
ANSI C63.4-2014  
Industry Canada Interference-Causing Equipment Standard ICES-003 Issue 7: 2020  
Class B

**Equipment Tested:** PCIe M.2 2280

**Main Model:** PX180-M280 (X=A~Z)

**Brand:** Apacer

**Applicant:** Apacer Technology Inc.

**Sample received Date:** July 13, 2022

**Final test Date:** refer to the date of test data

**Test Site:** Chamber 02; Conduction 02

**Test Distance:** 10m

**Temperature:** refer to each site test data

**Humidity:** refer to each site test data

**Input power:** Conduction input power: AC 120 V / 60 Hz  
Radiation input power: AC 120 V / 60 Hz

**Test Result:** PASS

**Report Engineer:** Cheryl Tung

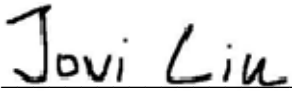
**Test Engineer:**   
Jovi Liu

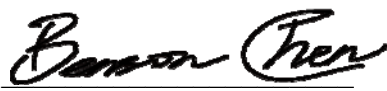
**Approved By:**   
Benson Chen / Manager

## 1.2 Description of EUT

### EUT

This report test data using the report number ISL-22LE0534FCCIC

Description	PCIe M.2 2280
Condition	Pre-Production
Main Model	PX180-M280 (X=A~Z)
Serial Number	N/A
Power	From Personal Computer Supply
Control IC	PS5021-E21T
PCB Number	Q175021DF004402E
Memory Capacity	1GB~2TB
Highest working frequency	30MHz

The memory capacities listed below is chosen by the applicant to be the representative configuration for testing in this report.

#### Test configurations:

Configuration	Control IC	PCB Number	Memory Capacity
1	PS5021-E21T	Q175021DF004402E	2TB

#### Different Model list:

Model	Market
PX180-M280 (X=A~Z)	Different customer

#### EMI Noise Source:

refer to the photo	Controller IC	Point
EUT-5	PS5021-E21T	U1

#### EMI Solution:

NA

### 1.3 Description of Support Equipment

No	Unit	Model / Serial No.	Brand	Power Cord	FCC ID
1	AKiTIO Type-C HDD	SK2-U31AS-AKT S/N: N/A	AKiTIO	N/A	FCC DOC
2	USB Keyboard	SK-8175 S/N: N/A	DELL	N/A	FCC DOC
3	USB Mouse	MOCZUL S/N: N/A	DELL	N/A	FCC DOC
4	Printer	C930 S/N: N/A	HP	Non-shielded	FCC DOC
5	LCD Monitor	P2715Q S/N: N/A	DELL	Non-shielded	FCC DOC
6	Personal Computer	B550 S/N: N/A	Gigabyte	Non-shielded	FCC DOC

#### 1.4 Software for Controlling Support Unit

Test programs exercising various part of EUT were used. The programs were executed as follows:

1. PC running Winthrax to read and write the EUT.
2. Send signal to the Printer through PC USB Port.
3. Read and write AKiTIO Type-C HDD through PC USB 3.0 Port.
4. Send H Pattern to the LCD Monitor through PC HDMI Port.
5. Repeat the above steps.

	<b>Filename</b>	<b>Version</b>
EUT	Winthrax	3.09.02
LCD Monitor	IntelEMC	1.1
Printer	IntelEMC	1.1
AKiTIO Type-C HDD	IntelEMC	1.1

### 1.5 I/O Cable Condition of EUT and Support Units

Description	Path	Length	Shielding	Core	Remark
AC Power Cable	100V (~240V) to PC SPS	1.8m	No	No	
HDMI Cable	LCD Monitor HDMI Port to PC HDMI Port	1.8m	Yes	No	
USB Keyboard Data Cable	USB Keyboard to PC USB 3.0 Port	1.8m	Yes	No	
USB Mouse Data Cable	USB Mouse to PC USB 3.0 Port	1.8m	Yes	No	
Printer Data Cable	Printer to PC USB Port	1.8m	Yes	No	
USB data cable	AKiTiO Type-C HDD to PC USB 3.0 port	1.27m	Yes	No	

## 2. Power Line Conducted Emissions

### 2.1 Test Setup and Procedure

#### 2.1.1 Test Setup

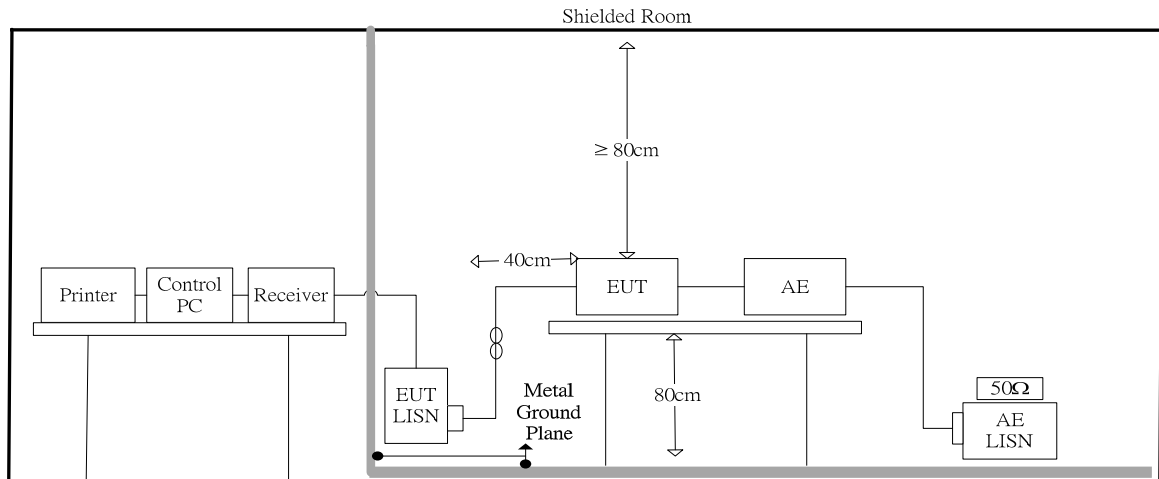

#### 2.1.2 Test Procedure

The measurements are performed in a shielded room test site. The EUT was placed on non-conduction 1.0m x 1.5m table, which is 0.8 meters above an earth-grounded.

Power to the EUT was provided through the LISN which has the Impedance (50ohm/50uH) vs. Frequency Characteristic in accordance with the standard. Power to the LISNs were filtered to eliminate ambient signal interference and these filters were bonded to the ground plane. Peripheral equipment required to provide a functional system (support equipment) for EUT testing was powered from the second LISN through a ganged, metal power outlet box which is bonded to the ground plane at the LISN.

The interconnecting cables were arranged and moved to get the maximum measurement. Both the line of power cord, hot and neutral, were measured. All of the interface cables were manipulated according to ANSI C63.4 requirements.

The highest emissions were analyzed in details by operating the spectrum analyzer in fixed tuned mode to determine the nature of the emissions and to provide information which could be useful in reducing their amplitude.

#### 2.1.3 EMI Receiver/Spectrum Analyzer Configuration (for the frequencies tested)

Frequency Range:	150kHz~30MHz
Detector Function:	Quasi-Peak / Average Mode
Resolution Bandwidth:	9kHz

**2.1.4 Limit**

**Conducted emissions limits of Class A equipment. (AC mains power terminals):**

Frequency range (MHz)	Quasi-peak (dBμV)	Average (dBμV)
0.15-0.50	79	66
0.50-5.0	73	60
5.0-30	73	60

Note 1: Conducted emissions limits of FCC CFR Title 47 Part 15 Subpart B & Industry Canada Interference-Causing Equipment Standard ICES-003 are same.

Note2: The more stringent limit applies at transition frequencies.

**Conducted emissions limits of Class B equipment. (AC mains power terminals):**

Frequency range (MHz)	Quasi-peak (dBμV)	Average (dBμV)
0.15-0.50	66 to 56*	56-46*
0.50-5.0	56	46
5.0-30	60	50

\*The limit level in dBμV decreases linearly with the logarithm of frequency.

Note 1: Conducted emissions limits of FCC CFR Title 47 Part 15 Subpart B & Industry Canada Interference-Causing Equipment Standard ICES-003 are same.

Note2: The more stringent limit applies at transition frequencies.

## 2.2 Conduction Test Data: Configuration 1

- Line

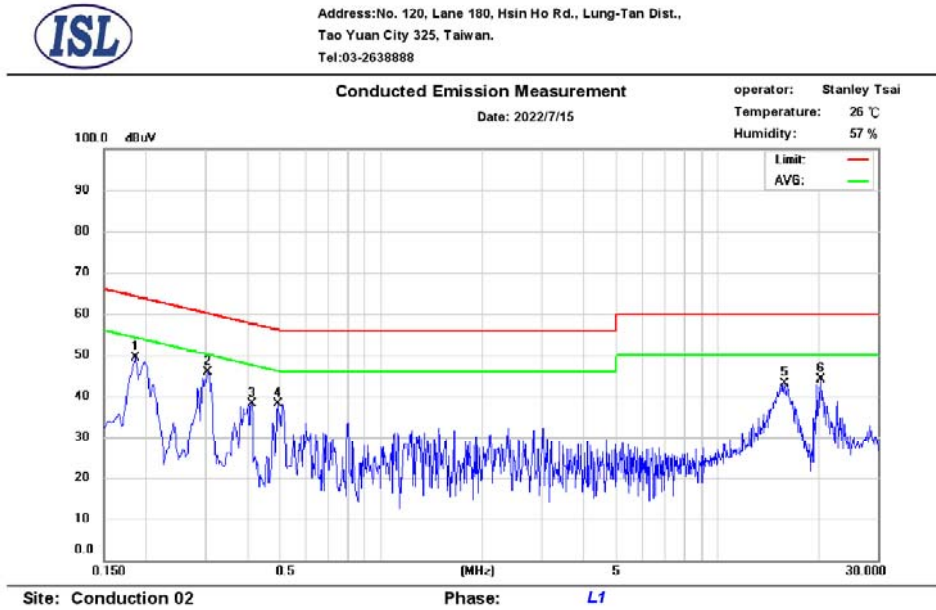

No.	Frequency (MHz)	QP_R (dBuV)	AVG_R (dBuV)	Correct Factor (dB)	QP Emission (dBuV)	QP Limit (dBuV)	QP Margin (dB)	AVG Emission (dBuV)	AVG Limit (dBuV)	AVG Margin (dB)
1	0.186	35.03	29.80	9.67	44.70	64.21	-19.51	39.47	54.21	-14.74
2	0.306	32.86	22.93	9.67	42.53	60.08	-17.55	32.60	50.08	-17.48
3	0.414	23.99	7.09	9.68	33.67	57.57	-23.90	16.77	47.57	-30.80
4	0.494	24.84	9.09	9.68	34.52	56.10	-21.58	18.77	46.10	-27.33
5	15.874	31.59	25.31	9.94	41.53	60.00	-18.47	35.25	50.00	-14.75
6	20.322	29.18	17.64	9.96	39.14	60.00	-20.86	27.60	50.00	-22.40

Note:

Margin = QP/AVG Emission - Limit

QP/AVG Emission = QP\_R/AVG\_R + Correct Factor

Correct Factor = LISN Loss + Cable Loss

A margin of -8dB means that the emission is 8dB below the limit

The frequency spectrum graph is for final peak graph, and the attached table is for QP/AVG test result.

If peak data can pass, it will be shown in "QP/AVG Correct" column, if not, QP/AVG data will instead.

The CISPR 22 limits would be applied to all FCC Part 15 devices.

- Neutral

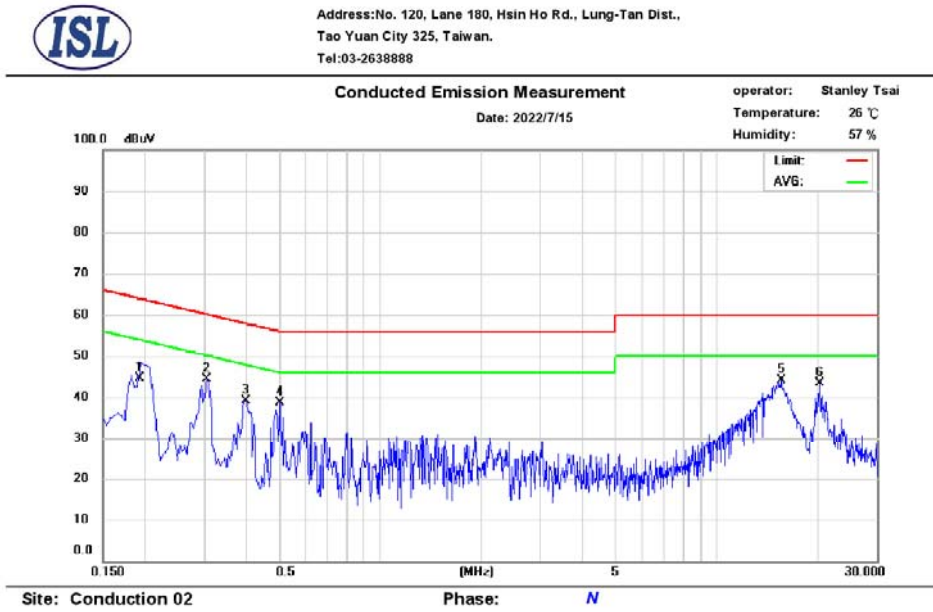

No.	Frequency (MHz)	QP_R (dBuV)	AVG_R (dBuV)	Correct Factor (dB)	QP Emission (dBuV)	QP Limit (dBuV)	QP Margin (dB)	AVG Emission (dBuV)	AVG Limit (dBuV)	AVG Margin (dB)
1	0.189	34.76	23.95	9.67	44.43	64.07	-19.64	33.62	54.07	-20.45
2	0.306	32.97	22.72	9.66	42.63	60.08	-17.45	32.38	50.08	-17.70
3	0.398	25.86	10.31	9.67	35.53	57.90	-22.37	19.98	47.90	-27.92
4	0.502	25.48	16.54	9.67	35.15	56.00	-20.85	26.21	46.00	-19.79
5	15.594	31.62	25.82	9.99	41.61	60.00	-18.39	35.81	50.00	-14.19
6	20.302	27.83	19.64	10.05	37.88	60.00	-22.12	29.69	50.00	-20.31

Note:

Margin = QP/AVG Emission - Limit

QP/AVG Emission = QP\_R/AVG\_R + Correct Factor

Correct Factor = LISN Loss + Cable Loss

A margin of -8dB means that the emission is 8dB below the limit

The frequency spectrum graph is for final peak graph, and the attached table is for QP/AVG test result.

If peak data can pass, it will be shown in "QP/AVG Correct" column, if not, QP/AVG data will instead.

The CISPR 22 limits would be applied to all FCC Part 15 devices.

### 2.3 Test Setup Photo

Front View



Back View

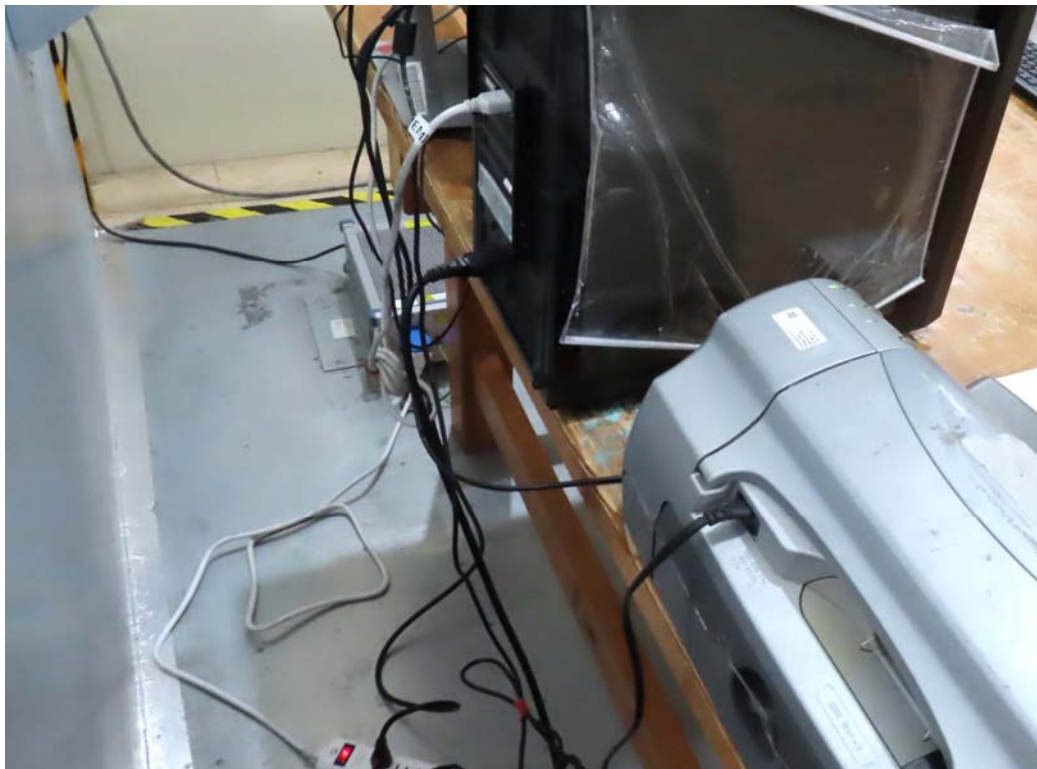

### 3. Radiated Emissions

#### 3.1 Test Setup and Procedure

##### 3.1.1 Test Setup

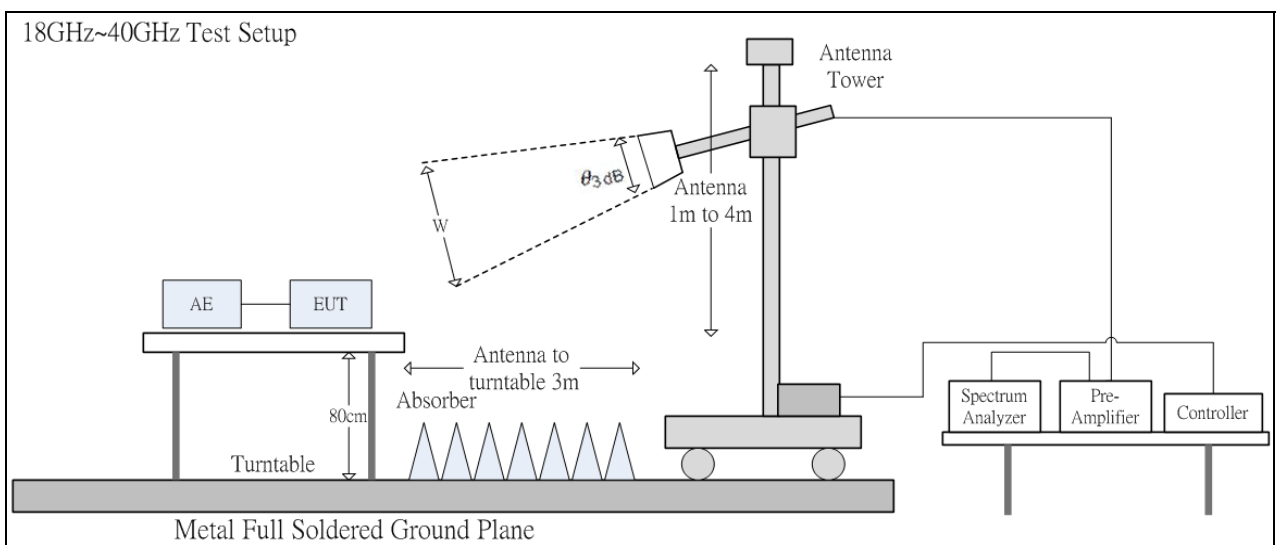
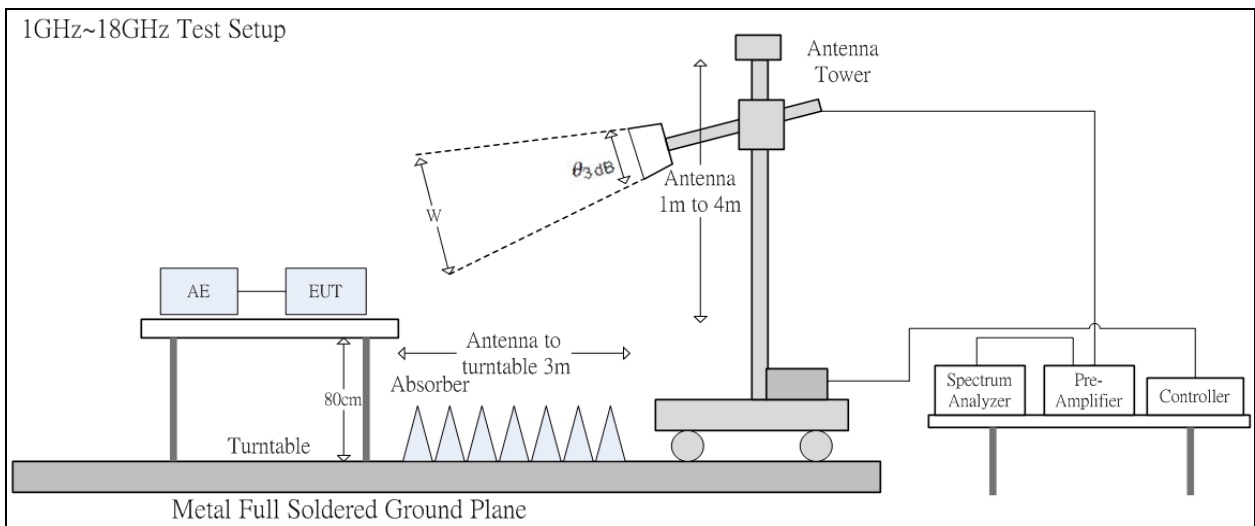
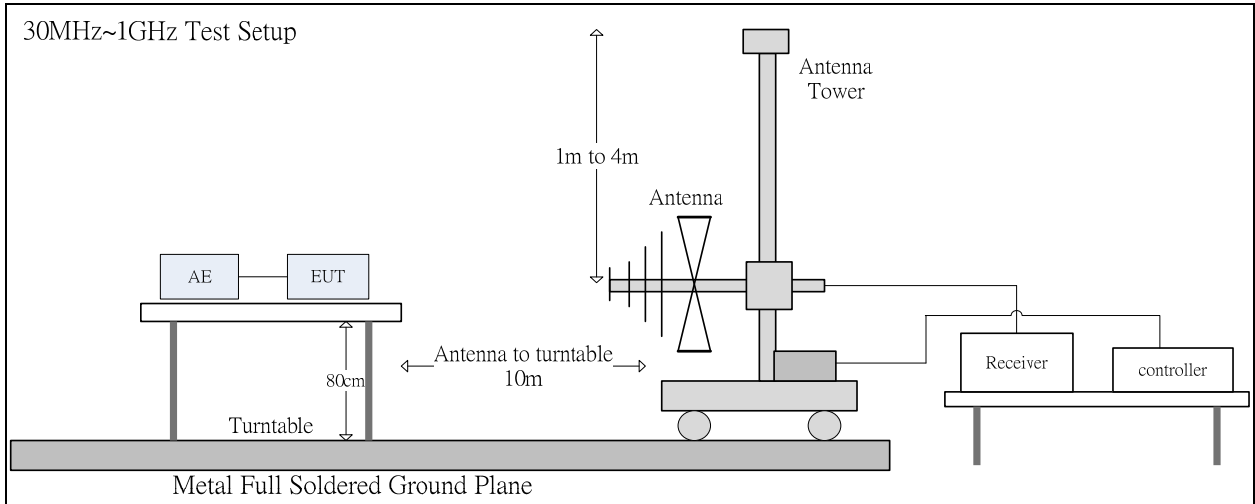

The 3dB beam width of the horn antenna used for the test is as shown in the table below.  
 1GHz~18GHz

Frequency GHz	E-plane	H-plane	$\theta_{3\text{ dB}}(\text{min})$	d= 3 m	
				w (m)	
1	88°	147°	88°	5.79	
2	68°	119°	68°	4.04	
3	73°	92°	73°	4.44	
4	70°	89°	70°	4.20	
5	55°	60°	55°	3.12	
6	63°	62°	62°	3.60	
7	48°	49°	48°	2.67	
8	39°	46°	39°	2.12	
9	32°	42°	32°	1.72	
10	30°	39°	30°	1.61	
11	32°	35°	32°	1.72	
12	35°	32°	35°	1.89	
13	34°	31°	31°	1.66	
14	32°	27°	27°	1.44	
15	36°	26°	26°	1.39	
16	40°	28°	28°	1.50	
17	43°	26°	26°	1.39	
18	41°	22°	22°	1.17	

18 GHz~26.5 GHz

Frequency GHz	E-plane	H-plane	$\theta_{3\text{ dB}}(\text{min})$	d= 1 m	d= 3 m
				w (m)	w (m)
18	11.4°	12.7°	11.4°	0.199	0.598
19	10.9°	12.4°	10.9°	0.190	0.572
20	10.8°	12.4°	10.8°	0.189	0.567
21	9.8°	12°	9.8°	0.171	0.514
22	9.7°	11°	9.7°	0.169	0.509
23	10°	11.8°	10°	0.174	0.524
24	9°	11°	9°	0.157	0.472
25	10°	12.3°	10°	0.174	0.524
26	9.9°	11.1°	9.9°	0.173	0.519
26.5	9.4°	11.3°	9.4°	0.164	0.493

26 GHz~40 GHz

Frequency GHz	E-plane	H-plane	$\theta_{3\text{ dB}}(\text{min})$	d= 1 m	d= 3 m
				w (m)	w (m)
26	12°	12.2°	12°	0.210	0.631
27	13°	10.5°	10.5°	0.184	0.551
28	13.2°	12.3°	12.3°	0.216	0.647
29	11.5°	12.8°	11.5°	0.201	0.604
30	12°	8°	8°	0.140	0.420
31	11.5°	10.1°	10.1°	0.177	0.530
32	11.8°	10°	10°	0.175	0.525
33	11.8°	9.5°	9.5°	0.166	0.499
34	11.6°	10°	10°	0.175	0.525
35	10.9°	9.8°	9.8°	0.171	0.514

36	11.8°	8.6°	8.6°	0.150	0.451
37	12.9°	10.5°	10.5°	0.184	0.551
38	12°	10.3°	10.3°	0.180	0.541
39	11.8°	9.8°	9.8°	0.171	0.514
40	12.5°	11.2°	11.2°	0.196	0.588

### 3.1.2 Test Procedure

The radiated emissions test will then be repeated on the chamber to measure the amplitudes accurately and without the multiple reflections existing in the shielded room. The EUT and support equipment are set up on the turntable of one of 10 meter chamber. Desktop EUT are set up on a wooden stand 0.8 meter above the ground or floor-standing arrangement shall be placed on the horizontal ground reference plane. The test volume for a height of up to 30 cm may be obstructed by absorber placed on the ground plane.

For the initial measurements, the receiving antenna is varied from 1-4 meter height and is changed in the vertical plane from vertical to horizontal polarization at each frequency. The highest emissions between 30 MHz to 1000 MHz were analyzed in details by operating the spectrum analyzer and/or EMI receiver in quasi-peak mode to determine the precise amplitude of the emissions. The highest emissions between 1 GHz to 40 GHz were analyzed in details by operating the spectrum analyzer in peak and average mode to determine the precise amplitude of the emissions.

Place the measurement antenna away from each area of the EUT determined to be a source of emissions at the specified measurement distance, while keeping the antenna in the cone of radiation from that area and pointed at the area both in azimuth and elevation, with polarization oriented for maximum response. At the highest amplitudes observed, the EUT is rotated in the horizontal plane while changing the antenna polarization in the vertical plane to maximize the reading. The interconnecting cables were arranged and moved to get the maximum measurement. Once the maximum reading is obtained, the antenna elevation and polarization will be varied between specified limits to maximize the readings. All of the interface cables were manipulated according to ANSI C63.4 requirements.

The highest internal source of the EUT is defined as the highest frequency generated or used within the EUT or on which the EUT operates or tunes. If the highest frequency of the internal sources of the EUT is less than 108 MHz, the measurement shall only be made up to 1 GHz. If the highest frequency of the internal sources of the EUT is between 108 MHz and 500 MHz, the measurement shall only be made up to 2 GHz. If the highest frequency of the internal sources of the EUT is between 500 MHz and 1 GHz, the measurement shall only be made up to 5 GHz. If the highest frequency of the internal sources of the EUT is above 1 GHz, the measurement shall be made up to 5 times the highest frequency or 40 GHz, whichever is less.

### 3.1.3 Spectrum Analyzer Configuration (for the frequencies tested)

Frequency Range: 30MHz--1000MHz  
 Detector Function: Quasi-Peak Mode  
 Resolution Bandwidth: 120kHz

Frequency Range: Above 1000MHz  
 Detector Function: Peak/Average Mode  
 Resolution Bandwidth: 1MHz

### 3.1.4 Limit

#### Radiated emissions limits of Class A equipment. (30 MHz to 1 GHz)

Frequency range (MHz)	FCC Part 15 Subpart B 15.109(g)	ICES-003
	at 10 m distance Quasi-peak (dB $\mu$ V/m)	at 10 m distance Quasi-peak (dB $\mu$ V/m)
30-88	40	40.0
88-216	40	43.5
216-230	40	46.4
230-960	47	47.0
960-1000	47	49.5

Note 1: The test limit in this report is based on FCC CFR Title 47 Part 15 Subpart B 15.109(g).

Note 2: The more stringent limit applies at transition frequencies.

Note 3: Test data in this report has been taken against the FCC CFR Title 47 Part 15 Subpart B 15.109(g) limit as it is the most stringent limit. By complying with the more restrictive Part 15 Subpart B 15.109(g) limit compliance with the Industry Canada Interference-Causing Equipment Standard ICES-003 limit is also demonstrated.

#### Radiated emission limits of Class A equipment at 3 m distance (at and above 1 GHz)

Frequency range (GHz)	Average dB( $\mu$ V/m)	Peak dB( $\mu$ V/m)
1 – 40G	60	80

Note 1: Radiated emissions limits of FCC CFR Title 47 Part 15 Subpart B & Industry Canada Interference-Causing Equipment Standard ICES-003 are same.

#### Radiated emissions limits of Class B equipment. (30 MHz to 1 GHz)

Frequency range (MHz)	FCC Part 15 Subpart B 15.109(g)	ICES-003
	at 10 m distance Quasi-peak (dB $\mu$ V/m)	at 10 m distance Quasi-peak (dB $\mu$ V/m)
30-88	30	30.0
88-216	30	33.1
216-230	30	35.6
230-960	37	37.0
960-1000	37	43.5

Note 1: The test limit in this report is based on FCC CFR Title 47 Part 15 Subpart B 15.109(g).

Note 2: The more stringent limit applies at transition frequencies.

Note 3: Test data in this report has been taken against the FCC CFR Title 47 Part 15 Subpart B 15.109(g) limit as it is the most stringent limit. By complying with the more restrictive Part 15 Subpart B 15.109(g) limit compliance with the Industry Canada Interference-Causing Equipment Standard ICES-003 limit is also demonstrated.

#### Radiated emission limits of Class B equipment at 3 m distance (at and above 1 GHz)

Frequency range (GHz)	Average dB( $\mu$ V/m)	Peak dB( $\mu$ V/m)
1 – 40G	54	74

Note 1: Radiated emissions limits of FCC CFR Title 47 Part 15 Subpart B & Industry Canada Interference-Causing Equipment Standard ICES-003 are same.

### 3.2 Radiation Test Data: Configuration 1 - Radiated Emissions (Horizontal)

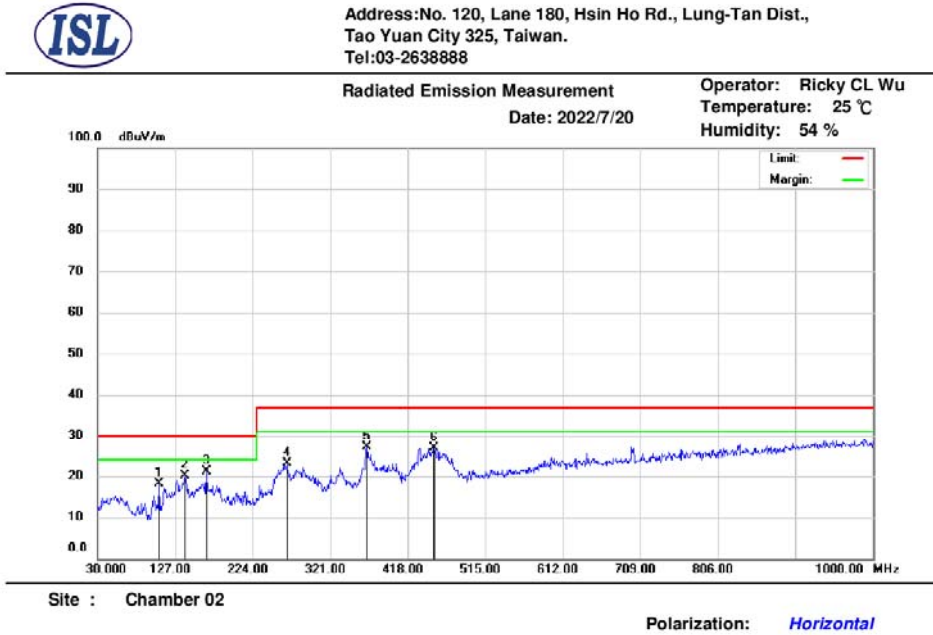

Mk.	Frequency (MHz)	RX R (dBuV)	Correct Factor (dB/m)	Emission (dBuV/m)	Limit (dBuV/m)	Margin (dB)	Ant.Pos (cm)	Tab.Pos (deg.)	Detector
1	106.63	37.65	-19.54	18.11	30.00	-11.89	400	89	QP
2	138.64	36.39	-16.37	20.02	30.00	-9.98	400	299	QP
3	165.80	36.83	-15.60	21.23	30.00	-8.77	399	360	QP
4	266.68	38.58	-15.46	23.12	37.00	-13.88	281	0	QP
5	366.59	39.34	-12.16	27.18	37.00	-9.82	209	0	QP
6	450.98	36.58	-9.60	26.98	37.00	-10.02	158	360	QP

\* Note:

Margin = Emission – Limit

Emission = Radiated Amplitude + Correct Factor

Correct Factor = Antenna Correction Factor + Cable Loss – Pre-Amplifier Gain

A margin of -8dB means that the emission is 8dB below the limit

Antenna Distance: 10 meters

The CISPR 22 limits would be applied to all FCC Part 15 devices.

Below 1GHz test, if the peak measured value meets the QP limit, it is unnecessary to perform the QP measurement.

**-Radiated Emissions (Vertical)**



Address: No. 120, Lane 180, Hsin Ho Rd., Lung-Tan Dist.,  
Tao Yuan City 325, Taiwan.  
Tel: 03-2638888

Radiated Emission Measurement      Operator: Ricky CL Wu  
Date: 2022/7/20                              Temperature: 25 °C  
Humidity: 54 %



Site : Chamber 02

Polarization: Vertical

Mk.	Frequency (MHz)	RX_R (dBuV)	Correct Factor(dB/m)	Emission (dBuV/m)	Limit (dBuV/m)	Margin (dB)	Ant.Pos (cm)	Tab.Pos (deg.)	Detector
1	34.85	43.09	-18.20	24.89	30.00	-5.11	328	360	QP
2	88.20	42.40	-22.23	20.17	30.00	-9.83	200	257	QP
3	128.94	39.73	-17.59	22.14	30.00	-7.86	200	280	QP
4	148.34	35.38	-15.64	19.74	30.00	-10.26	100	36	QP
5	166.77	36.78	-15.66	21.12	30.00	-8.88	100	81	QP
6	285.11	34.74	-14.29	20.45	37.00	-16.55	141	360	QP

\* Note:

Margin = Emission – Limit

Emission = Radiated Amplitude + Correct Factor

Correct Factor = Antenna Correction Factor + Cable Loss – Pre-Amplifier Gain

A margin of -8dB means that the emission is 8dB below the limit

Antenna Distance: 10 meters

The CISPR 22 limits would be applied to all FCC Part 15 devices.

Below 1GHz test, if the peak measured value meets the QP limit, it is unnecessary to perform the QP measurement.

### 3.3 Test Setup Photo

Front View (30MHz~1GHz)



Back View (30MHz~1GHz)

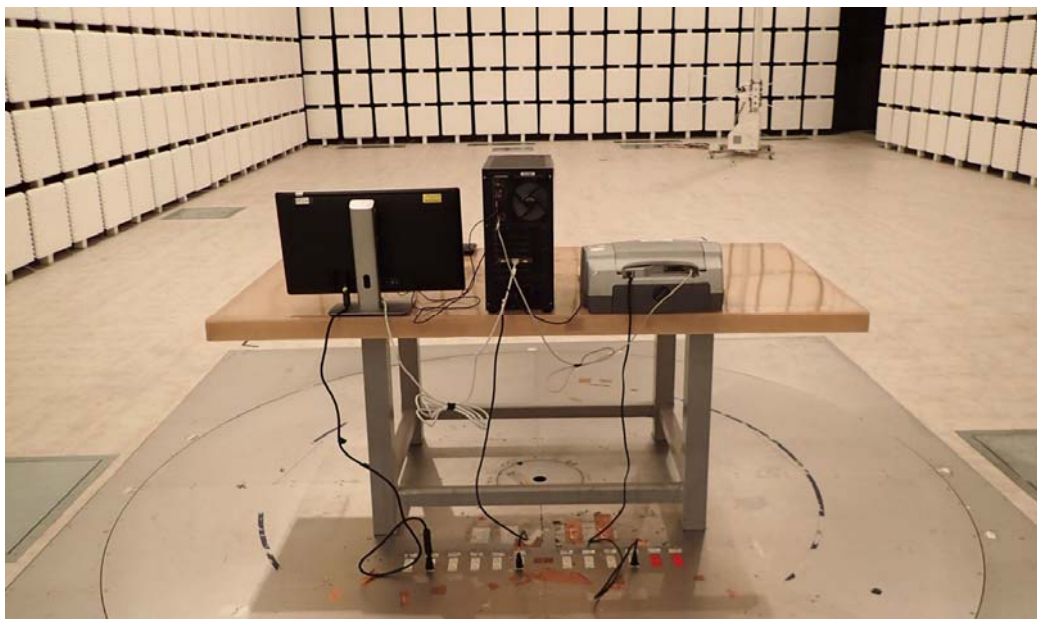

## 4. Appendix

### 4.1 Appendix A: (FCC)Warning Labels

#### Label Requirements

A Class B digital device subject to authorization under Supplier's Declaration of Conformity of FCC shall carry a label which includes the following statement:

**\* \* \* W A R N I N G \* \* \***

This device complies with Part 15 of the FCC Rules. Operation is subject to the following two conditions: (1) this device may not cause harmful interference, and (2) this device must accept any interference received, including interference that may cause undesired operation.

Devices subject to authorization under Supplier's Declaration of Conformity may be labeled with FCC logo on a voluntary basis as a visual indication that the product complies with the applicable FCC requirements

The sample label shown shall be permanently affixed at a conspicuous location on the device and be readily visible to the user at the time of purchase.

When the device is so small or for such use that it is impracticable to label it with the statement specified under (§15.19 Labeling requirements) paragraph (a) of this section in a font that is four-point or larger, and the device does not have a display that can show electronic labeling, then the information required by this paragraph shall be placed in the user manual and must also either be placed on the device packaging or on a removable label attached to the device.

## 4.2 Appendix B: (FCC)Warning Statement

### Statement Requirements

The operators' manual for a Class B digital device shall contain the following statements or their equivalent:

**\* \* \* W A R N I N G \* \* \***

This equipment has been tested and found to comply with the limits for a Class B digital device, pursuant to part 15 of the FCC Rules. These limits are designed to provide reasonable protection against harmful interference in a residential installation. This equipment generates, uses and can radiate radio frequency energy and, if not installed and used in accordance with the instructions, may cause harmful interference to radio communications. However, there is no guarantee that interference will not occur in a particular installation. If this equipment does cause harmful interference to radio or television reception, which can be determined by turning the equipment off and on, the user is encouraged to try to correct the interference by one or more of the following measures:

- Reorient or relocate the receiving antenna.
- Increase the separation between the equipment and receiver.
- Connect the equipment into an outlet on a circuit different from that to which the receiver is connected.
- Consult the dealer or an experienced radio/TV technician for help.

Notice: The changes or modifications not expressly approved by the party responsible for compliance could void the user's authority to operate the equivalent.

\* \* \* \* \*

If the EUT was tested with special shielded cables the operator's manual for such product shall also contain the following statements or their equivalent:

Shielded interface cables and/or AC power cord, if any, must be used in order to comply with the emission limits.

### 4.3 Appendix C: (Canada ISED) Labelling and user manual requirements

The requirements specified in ICES-Gen shall apply. An example ISED compliance label, to be placed on each unit of an equipment model (or in the user manual, if allowed), is given below:

**CAN ICES-003(\*) / NMB-003(\*)**

\* Insert either “A” or “B”, but not both, to identify the applicable Class of the device used for compliance verification.

The above label is only an example. The specific format is left to the manufacturer to decide, as long as the label includes the required information, in accordance with ICES-Gen.

#### 4.4 Appendix D: Test Equipment

##### 4.4.1 Test Equipment List

Location	Equipment Name	Brand	Model	S/N	Last Cal. Date	Next Cal. Date
Conduction 02	EMI Receiver 14	ROHDE& SCHWARZ	ESCI	101034	05/25/2022	05/25/2023
Conduction 02	Conduction 02-1 Cable	WOKEN	CFD 300-NL	Conduction 02 -1	10/13/2021	10/13/2022
Conduction 02	LISN 26	R&S	ENV216	102378	12/03/2021	12/03/2022
Conduction 02	LISN 15	R&S	ENV216	101335	12/03/2021	12/03/2022

Location Chamber02	Equipment Name	Brand	Model	S/N	Last Cal. Date	Next Cal. Date
Radiation	BILOG Antenna 17 (30MHz~1GHz)	SCHWARZBECK	VULB 9168+EMCI-N-6-05	645	05/18/2022	05/18/2023
Radiation	Preamplifier 25	EMCI	EMC9135	980295	03/31/2022	03/31/2023
Radiation	Coaxial Cable Chmb 02-10M-02	EMC	RG214U	Chmb 02-10M-02	10/13/2021	10/13/2022
Radiation	EMI Receiver 13	ROHDE & SCHWARZ	ESCI	101015	06/07/2022	06/07/2023

##### 4.4.2 Software for Controlling Spectrum/Receiver and Calculating Test Data

Site	Filename	Version
Conduction/Radiation	EZ EMC	ISL-03A2

#### 4.5 Appendix E: Uncertainty of Measurement

The laboratory measurement uncertainty accordance with refers to CISPR 16-4-2. If  $U_{lab}$  is less than or equal to  $U_{cispr}$  in Table 1, then the test report may either state the value of  $U_{lab}$  or state that  $U_{lab}$  is less than  $U_{cispr}$ .

The coverage factor  $k = 2$  yields approximately a 95 % level of confidence.

<Conduction 02>

AMN:  $\pm 2.90\text{dB}$

<Chamber 02 (10m)>

Horizontal

30MHz~200MHz:  $\pm 4.42\text{dB}$

200MHz~1000MHz:  $\pm 3.83\text{dB}$

Vertical

30MHz~200MHz:  $\pm 4.57\text{dB}$

200MHz~1000MHz:  $\pm 3.97\text{dB}$

#### **4.6 Appendix F: Photographs of EUT**

Please refer to the File of **ISL-22LE0534P-MF**

--- END ---