



# CE EMC Test Report

Issued date: Nov. 04, 2020

Project No.: 20Q101603

**Product :** PCIe M.2 2242

**Model :** PV220-M242, PX220-M242 (X=A~Z)

**Applicant :** Apacer Technology Inc.

**Address :** 1F., No.32, Zhongcheng Rd., Tucheng Dist., New Taipei City 236,  
Taiwan (R.O.C)

**Report No: WD-EE-R-200320-A0**

## According to

**EN 55032: 2015 + AC: 2016, Class B**

**CISPR 32: 2015**

**EN 61000-3-2: 2014**

**EN 61000-3-3: 2013**

**EN 55035: 2017**

IEC 61000-4-2: 2008

IEC 61000-4-3: 2006 + A1: 2007 + A2: 2010

IEC 61000-4-4: 2012

IEC 61000-4-5: 2014 + A1: 2017

IEC 61000-4-6: 2013

IEC 61000-4-8: 2009

IEC 61000-4-11: 2004 + A1: 2017

**Authorized Signatory :**  / Ken Huang



**Wendell Industrial Co., Ltd**  
**Wendell EMC & RF Laboratory**

Add: 6F/6F-1, No.188, Baoqiao Rd., Xindian Dist., New Taipei City 23145, Taiwan R.O.C.



### Table of Contents

- 1 Certification ..... 6**
- 1.1 Summary of Test Result..... 7**
- 2 Test Configuration of Equipment Under Test ..... 8**
- 2.1 Test Facility..... 8**
- 2.2 Measurement Uncertainty ..... 9**
- 2.2.1 Conducted Emission test..... 9
- 2.2.2 Conducted emission at telecom port test ..... 9
- 2.2.3 Radiated Emission test..... 9
- 2.2.4 Harmonics Current Measurement ..... 10
- 2.2.5 Voltage Fluctuation and Flicker Measurement..... 10
- 2.2.6 Immunity Test..... 10
- 3 General Information..... 11**
- 3.1 Description of EUT..... 11**
- 3.2 Description of Test Modes..... 12**
- 3.3 EUT Operating Condition ..... 12**
- 3.4 Description of Support Unit ..... 13**
- 3.5 Configuration of System Under Test..... 13**
- 4 Emission Test..... 14**
- 4.1 Conducted Emission Measurement ..... 14**
- 4.1.1 Limit of Conducted Emission Measurement ..... 14
- 4.1.2 Test Instrument ..... 15
- 4.1.3 Test Procedure..... 16
- 4.1.4 Deviation from Test Standard ..... 16
- 4.1.5 Test Setup..... 17
- 4.1.6 Test Result ..... 18
- 4.1.7 Photographs of Test Configuration ..... 22
- 4.2 Conducted Emission at Telecommunication Ports Test ..... 23**
- 4.3 Radiated Emission Measurement ..... 24**
- 4.3.1 Limits of Radiated Emission Measurement ..... 24
- 4.3.2 Test Instrument ..... 26
- 4.3.3 Test Procedure..... 27
- 4.3.4 Deviation from Test Standard ..... 27
- 4.3.5 Test Setup..... 28
- 4.3.6 Test Result ..... 31
- 4.3.7 Photographs of Test Configuration ..... 35
- 4.4 Harmonics Current Measurement..... 37**
- 4.5 Voltage Fluctuation and Flicker Measurement ..... 38**
- 5 Immunity Test ..... 39**
- 5.1 Standard Description ..... 39**
- 5.2 Performance Criteria ..... 40**
- 5.3 Electrostatic Discharge (ESD)..... 41**
- 5.3.1 Test Specification..... 41
- 5.3.2 Test Instrument ..... 41
- 5.3.3 Test Procedure..... 42
- 5.3.4 Deviation from Test Standard ..... 43



5.3.5 Test Setup..... 43

5.3.6 Test Result ..... 45

5.3.7 Photographs of Test Configuration ..... 50

**5.4 Radiated, Radio-frequency, Electromagnetic Field Immunity Test (RS)..... 51**

5.4.1 Test Specification..... 51

5.4.2 Test Instrument ..... 52

5.4.3 Test Procedure..... 53

5.4.4 Deviation from Test Standard ..... 53

5.4.5 Test Setup..... 54

5.4.6 Test Result ..... 55

5.4.7 Photographs of Test Configuration ..... 56

**5.5 Electrical Fast Transient /Burst Immunity Test (EFT)..... 57**

**5.6 Surge Immunity Test..... 58**

**5.7 Continuous Conducted Disturbances (CS) ..... 59**

**5.8 Power Frequency Magnetic Field Immunity Test ..... 60**

5.8.1 Test Specification..... 60

5.8.2 Test Instrument ..... 60

5.8.3 Test Procedure..... 60

5.8.4 Deviation from Test Standard ..... 60

5.8.5 Test Setup..... 61

5.8.6 Test Result ..... 62

5.8.7 Photographs of Test Configuration ..... 63

**5.9 Voltage Dips & Short Interruptions ..... 64**



### History of this test report

Report No.	Issue date	Description
WD-EE-R-200320-A0	Nov. 04, 2020	Initial Issue

#### Declaration

This report is for your exclusive use. Any copying or replication of this report to or for any other person or entity, or use of our name or trademark, is permitted only with our prior written permission. This report sets forth our findings solely with respect to the test samples identified herein. The results set forth in this report are not indicative or representative of the quality or characteristics of the lot from which a test sample was taken or any similar or identical product unless specifically and expressly noted. Our report includes all of the tests requested by you and the results thereof based upon the information that you provided to us.



### History of supplementary report

Report No.	Issue date	Description
WD-EE-R-200320-A0	Nov. 04, 2020	Original report

**Declaration**

This report is for your exclusive use. Any copying or replication of this report to or for any other person or entity, or use of our name or trademark, is permitted only with our prior written permission. This report sets forth our findings solely with respect to the test samples identified herein. The results set forth in this report are not indicative or representative of the quality or characteristics of the lot from which a test sample was taken or any similar or identical product unless specifically and expressly noted. Our report includes all of the tests requested by you and the results thereof based upon the information that you provided to us.



## 1 Certification

**Product:** PCIe M.2 2242

**Brand Name:** Apacer

**Model:** PV220-M242, PX220-M242 (X=A~Z)

**Applicant:** Apacer Technology Inc.

**Tested:** Oct. 21 ~ Oct. 28, 2020

**Standard:** **EN 55032: 2015 + AC: 2016, Class B**  
**CISPR 32: 2015**  
**EN 61000-3-2: 2014**  
**EN 61000-3-3: 2013**  
**EN 55035: 2017**  
IEC 61000-4-2: 2008  
IEC 61000-4-3: 2006 + A1: 2007 + A2: 2010  
IEC 61000-4-4: 2012  
IEC 61000-4-5: 2014 + A1: 2017  
IEC 61000-4-6: 2013  
IEC 61000-4-8: 2009  
IEC 61000-4-11: 2004 + A1: 2017

The above equipment (Model: PV220-M242) has been tested by **Wendell EMC & RF Laboratory**, and found compliance with the requirement of the above standards. The test record, data evaluation and Equipment Under Test (EUT) configurations represented herein are true and accurate accounts of the measurements of the sample's EMC characteristics under the conditions specified in this report.

Please note that the measurement uncertainty are provided for informational purpose only and are not used in determining the Pass/Fail results.

## 1.1 Summary of Test Result

The EUT has been tested according to the following specifications:

Emission				
Standard	Test Item	Limit	Result	Remark
EN 55032	Conducted disturbance at mains terminals	Class B	Pass	Meets the requirements
CISPR 32	Conducted disturbance at telecommunication ports test	-	N/A	Without telecom port of the EUT
	Radiated disturbance	Class B	Pass	Meets the requirements
EN 61000-3-2	Harmonic current emissions	-	N/A	Without AC main power port of the EUT
EN 61000-3-3	Voltage fluctuations and flicker	-	N/A	Without AC main power port of the EUT

Immunity			
Standard	Test Item	Result	Remark
IEC 61000-4-2	Electrostatic discharges (ESD)	Pass	Meets the requirements of Performance Criterion A
IEC 61000-4-3	Continuous radiated disturbances (RS)	Pass	Meets the requirements of Performance Criterion A
IEC 61000-4-4	Electrical fast transients (EFT)	N/A	Without AC main power port of the EUT
IEC 61000-4-5	Surges	N/A	Without AC main power port of the EUT
IEC 61000-4-6	Continuous conducted disturbances (CS)	N/A	Without AC main power port of the EUT
IEC 61000-4-8	Power-frequency magnetic fields (PFMF)	Pass	Meets the requirements of Performance Criterion A
IEC 61000-4-11	Voltage dips and interruptions	N/A	Without AC main power port of the EUT

**Note:** Test record contained in the referenced test report relate only to the EUT sample and test item.

## **2 Test Configuration of Equipment Under Test**

### **2.1 Test Facility**

**Conducted disturbance at mains terminals, Conducted disturbance at telecommunication ports, Harmonics, Flicker, ESD, EFT, Surge, CS, PFMF and DIP Tests**

W01: 5F-1, No.188, Baoqiao Rd., Xindian Dist., New Taipei City 23145, Taiwan (R.O.C)

#### **RS Test**

W05: 1F-7, No.188, Baoqiao Rd., Xindian Dist., New Taipei City 23145, Taiwan (R.O.C)

#### **Radiated emission (9\*6\*6 Chamber) Test**

W08: No.119, Wugong 3rd Rd., Wugu Dist., New Taipei City 248, Taiwan (R.O.C)

#### **ACCREDITATIONS**

The laboratories are accredited and approved by the TAF according to ISO/IEC 17025.

## 2.2 Measurement Uncertainty

The measurement instrumentation uncertainty is evaluated according to CISPR 16-4-2.

This uncertainty represents an expanded uncertainty expressed at approximately the 95% confidence level using a coverage factor of  $k=2$ .

Wendell EMC & RF Laboratory  $U_{lab}$  is less than  $U_{cispr}$ , therefore compliance or non-compliance with a disturbance limit shall be determined in the following manner.

- compliance is deemed to occur if no measured disturbance level exceeds the disturbance limit;
- non-compliance is deemed to occur if any measured disturbance level exceeds the disturbance limit.

Please note that the measurement uncertainty ( $U_{lab}$ ) is provided for informational purpose only and is not used in determining the Pass/Fail results.

### 2.2.1 Conducted Emission test

Test Site	Measurement Freq. Range	dB ( $U_{lab}$ )	Note
W01	150 kHz ~ 30 MHz	2.72	N/A

### 2.2.2 Conducted emission at telecom port test

Test Site	Measurement Freq. Range	dB ( $U_{lab}$ )	Note
W01	150 kHz ~ 30 MHz	2.72	N/A

### 2.2.3 Radiated Emission test

Test Site	Measurement Freq. Range	Ant	dB ( $U_{lab}$ )	Note
W08	30 MHz ~ 200 MHz	V	3.68	N/A
	30 MHz ~ 200 MHz	H	2.70	N/A
	200 MHz ~ 1000 MHz	V	5.19	N/A
	200 MHz ~ 1000 MHz	H	3.26	N/A
	1 GHz ~ 6 GHz	V	4.98	N/A
	1 GHz ~ 6 GHz	H	5.07	N/A

### 2.2.4 Harmonics Current Measurement

Test Site	Expanded Uncertainty	
W01	Voltage	0.17 %
	Current	0.39 %

### 2.2.5 Voltage Fluctuation and Flicker Measurement

Test Site	Expanded Uncertainty	
W01	P <sub>st</sub>	0.87 %

### 2.2.6 Immunity Test

Test Site	Item	Expanded Uncertainty		Note
W01	Electrostatic Discharge (ESD)	Voltage	1.8%	k=2
		Timing	6.0%	
		Current	2.5%	
	Electrical fast transients (EFT)	Voltage	6.2%	k=2
		Timing	5.1%	
	Surges	Voltage	5.7%	k=2
		Current	5.2%	
		Timing	5.5%	
	Continuous conducted disturbances (CS)	CDN	1.44dB	150kHz ~ 230MHz, k=2
		EM Clamp	4.09dB	
Power-frequency magnetic fields (PFMF)	Magnetic Field Strength	1.0%	N/A	
Voltage dips and interruptions	Voltage	5.2%	k=2	
	Timing	4.7%		
W05	Continuous radiated disturbances (RS)	80MHz – 1GHz	1.41dB	80MHz - 6GHz, k=2
		1GHz – 6GHz	1.44dB	



### 3 General Information

#### 3.1 Description of EUT

<b>Product</b>	PCIe M.2 2242
<b>Brand</b>	Apacer
<b>Model</b>	PV220-M242, PX220-M242 (X=A~Z)
<b>Applicant</b>	Apacer Technology Inc.
<b>Received Date</b>	Oct. 16, 2020
<b>EUT Power Rating</b>	5Vdc (from host equipment)
<b>Model Differences</b>	The models are electrically identical, different models no. are for marketing purpose. This series model information is provided by client.
<b>Operating System</b>	N/A
<b>Data Cable Supplied</b>	N/A
<b>Accessory Device</b>	N/A
<b>I/O Port</b>	Please refer to the User's Manual

**Note:**

1. The EUT's highest operating frequency is more than 108MHz. Therefore the radiated emission is tested up to 6GHz.

### 3.2 Description of Test Modes

Test results are presented in the report as below.

Test Mode	Test Condition
<b>Conducted emission test</b>	
-	Normal mode
<b>Radiated emission 30MHz ~ 1GHz test</b>	
-	Normal mode
<b>Radiated emission above 1GHz test</b>	
-	Normal mode
<b>ESD, RS and PFMF test</b>	
-	Normal mode

### 3.3 EUT Operating Condition

- Inserted the EUT into PC and placed on test table.
- The PC run test program "BurnIN.exe" to enable all functions.
- The PC sent "Color Bar ITU-R.BT471-1" signal to monitor and displayed on screen.
- The microphone sent voice signal to PC.
- The PC sent voice signal to earphone.
- The PC sent signal to printer.
- The EUT read/write data.

### 3.4 Description of Support Unit

The EUT has been conducted testing with other necessary accessories or support units.

Item	Equipment	Brand	Model No.	Serial No.	FCC ID	Data Cable	Power Cord	Remark
1	PC	DELL	D24M	N/A	PD93165NG	N/A	1.8m non-shielded cable	-
2	Monitor	DELL	P2317H	N/A	FCC DoC Approved	1.5m shielded HDMI cable	1.8m non-shielded cable	-
3	Keyboard	DELL	KB4021	N/A	FCC DoC Approved	1.5m non-shielded cable	N/A	-
4	Mouse	DELL	MS111-L	N/A	FCC DoC Approved	1.5m non-shielded cable	N/A	-
5	Earphone & Microphone	E-books	E-EPA057	N/A	N/A	1.4m non-shielded cable	N/A	-
6	Printer	HP	SNPRH-1504	CN738282V9	FCC DoC Approved	1.4m shielded cable	AC: 1.7m non-shielded cable	-

**Note:** 1. The core(s) is(are) originally attached to the cable(s).

### 3.5 Configuration of System Under Test

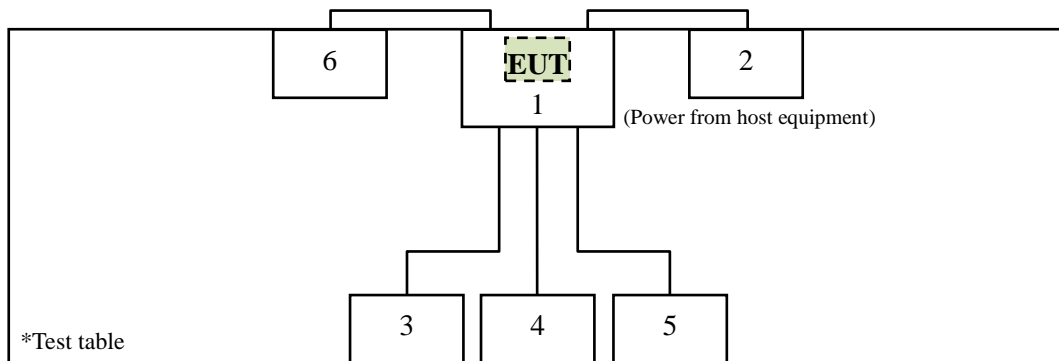

## 4 Emission Test

### 4.1 Conducted Emission Measurement

#### 4.1.1 Limit of Conducted Emission Measurement

Class A equipment:

Requirements for conducted emissions from the AC mains power ports of Class A equipment			
Frequency (MHz)	Measurement		Class A limits dB(uV)
	Coupling device	Detector type/ bandwidth	
0.15 to 0.5	AMN	Quasi Peak / 9 kHz	79
0.5 to 30			73
0.15 to 0.5	AMN	Average / 9 kHz	66
0.5 to 30			60

Class B equipment:

Requirements for conducted emissions from the AC mains power ports of Class B equipment			
Frequency (MHz)	Measurement		Class B limits dB(uV)
	Coupling device	Detector type/ bandwidth	
0.15 to 0.5	AMN	Quasi Peak / 9 kHz	66 to 56*
0.5 to 5			56
5 to 30			60
0.15 to 0.5	AMN	Average / 9 kHz	56 to 46*
0.5 to 5			46
5 to 30			50

\* Decreases with the logarithm of the frequency.

- Note:**
- The lower limit shall apply at the transition frequencies.
  - Detector function in the form: PK = Peak, QP = Quasi Peak, AV = Average
  - The test result calculated as following:  
 Measurement Value = Reading Level + Correct Factor  
 Correction Factor = Insertion loss of LISN + Cable loss + Transient Limiter (If use)  
 Margin Level = Measurement Value – Limit Value

#### 4.1.2 Test Instrument

Test Site: W01-CE					
Item	Equipment	Manufacturer	Model	Meter No.	Calibration Date
1	TWO-LINE V-NETWORK	R&S	ENV216	CT-1-025-1	Apr. 29, 2020
2	Pulse limiter	R&S®	ESH3-Z2	CT-2-015	Apr. 27, 2020
3	EMI Test Receiver	R&S	ESCI	CT-1-024	Apr. 29, 2020
4	V-LISN	Schwarzbeck	NSLK8127	CT-1-104-1	Apr. 29, 2020
5	Test Cable	Marvelous Microwave Inc	200200.400LL.500A	CT-10-048-1	Apr. 27, 2020
6	50ohm Termination	N/A	N/A	CT-1-065-1	Apr. 28, 2020
7	Measurement Software	EZ-EMC	Ver: EMC-CON 3A1	CT-3-012	No calibration request

**Note:** 1. The calibration interval of the above test instruments is 12 months.

### 4.1.3 Test Procedure

- a. The table-top EUT was placed 0.8 meter height wooden table from the horizontal ground plane with EUT being connected to power source through a line impedance stabilization network (LISN). The floor-standing EUT was placed insulation support unit from the horizontal ground plane. The LISN at least be 80 cm from nearest chassis of EUT.
- b. The line impedance stabilization network (LISN) provides 50 ohm/50uH of coupling impedance for the measuring instrument. All other support equipments powered from additional LISN(s).
- c. Interrelating cables that hang closer than 40 cm to the ground plane shall be folded back and forth in the center forming a bundle. All I/O cables were positioned to simulate typical usage.
- d. All I/O cables that are not connected to a peripheral shall be bundle in the center. The end of the cable may be terminated, if required, using the correct terminating impedance. The overall length shall not exceed 1 m.
- e. The EMI test receiver connected to LISN powering the EUT. The actual test configuration, please refer to EUT test photos.
- f. The receiver scanned from 150kHz to 30MHz for emissions in each of test modes. A scan was taken on both power lines, Line and Neutral, recording at least six highest emissions.
- g. The EUT and cable configuration of the above highest emission levels were recorded. The test data of the worst case was recorded.

### 4.1.4 Deviation from Test Standard

No deviation

### 4.1.5 Test Setup

#### < Table-Top equipment >

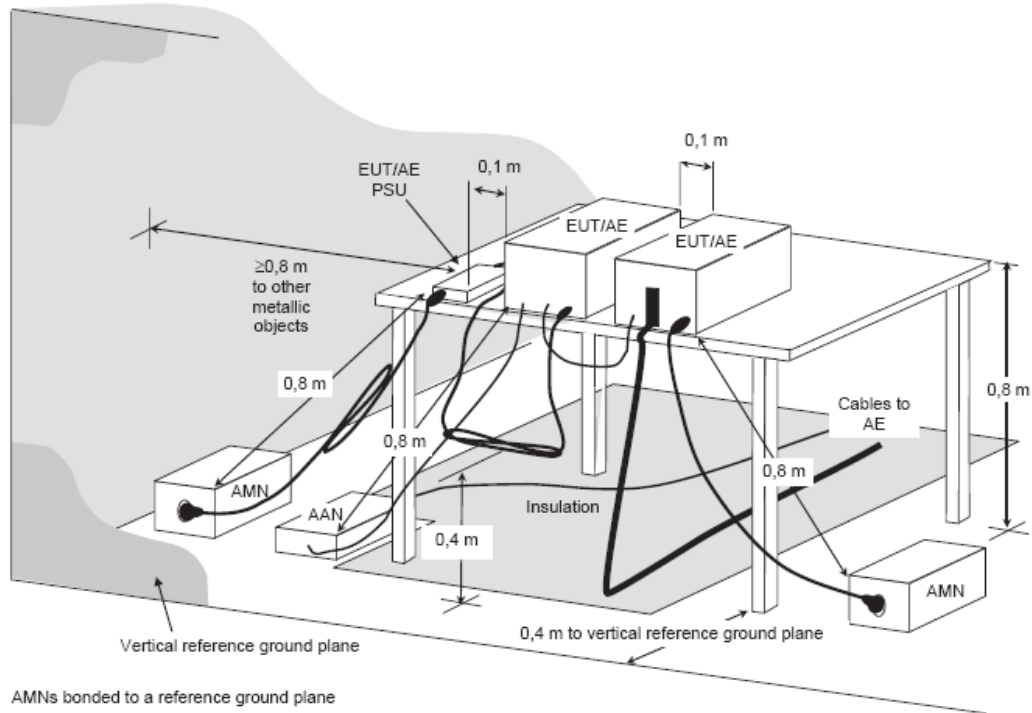

#### < Floor-Standing equipment >

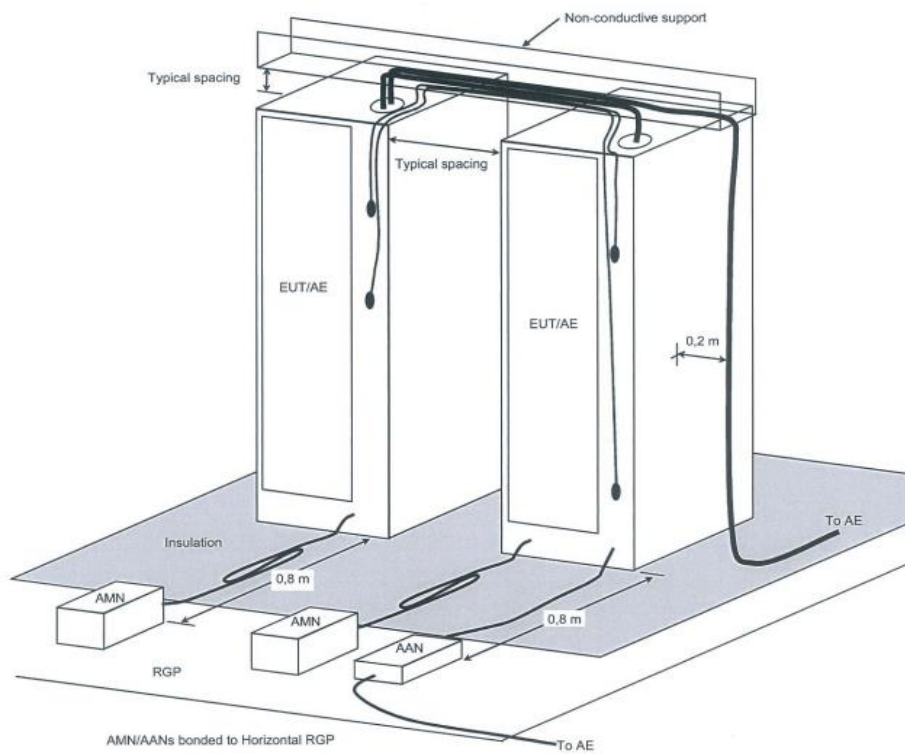

**Note:** Please refer to 4.1.7 for the actual test configuration.

### 4.1.6 Test Result

Test Voltage	230Vac, 50Hz	Frequency Range	0.15-30 MHz
Environmental Conditions	24°C, 60% RH	6dB Bandwidth	9 kHz
Test Date	2020/10/21	Phase	L
Tested by	Guanwei Liao	Test Site	W01

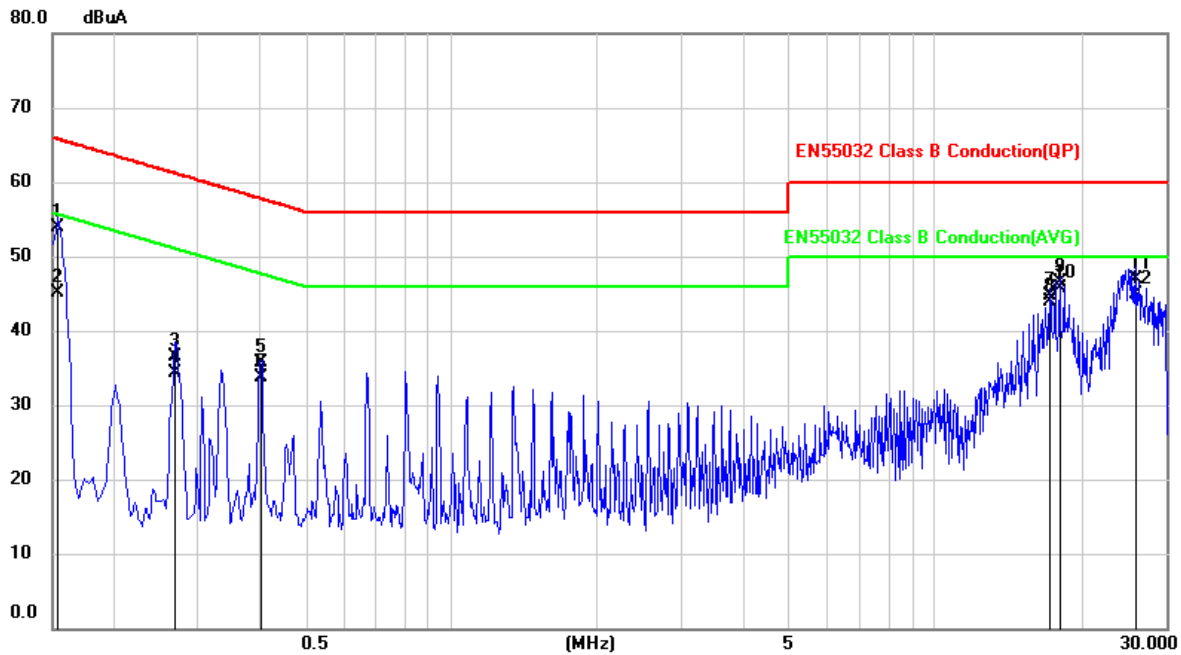

No.	Frequency (MHz)	Reading Level (dBuV)	Correct Factor (dB)	Measurement (dBuV)	Limit (dBuV)	Margin (dB)	Detector
1	0.1535	43.97	10.02	53.99	65.81	-11.82	QP
2	0.1535	35.03	10.02	45.05	55.81	-10.76	AVG
3	0.2673	26.46	10.02	36.48	61.20	-24.72	QP
4	0.2673	24.20	10.02	34.22	51.20	-16.98	AVG
5	0.4034	25.72	10.03	35.75	57.78	-22.03	QP
6	0.4034	23.59	10.03	33.62	47.78	-14.16	AVG
7	17.2856	34.33	10.47	44.80	60.00	-15.20	QP
8	17.2856	33.40	10.47	43.87	50.00	-6.13	AVG
9	18.0522	35.92	10.49	46.41	60.00	-13.59	QP
10	18.0522	35.31	10.49	45.80	50.00	-4.20	AVG
11	25.9262	36.22	10.64	46.86	60.00	-13.14	QP
12	25.9262	34.21	10.64	44.85	50.00	-5.15	AVG

**Remark:**

1. QP = Quasi Peak, AVG = Average
2. Correction Factor = Insertion loss of LISN + Cable loss + Transient Limiter (If use)
3. Measurement Value = Reading Level + Correct Factor
4. Margin Level = Measurement Value - Limit Value



<b>Test Voltage</b>	230Vac, 50Hz	<b>Frequency Range</b>	0.15-30 MHz
<b>Environmental Conditions</b>	24°C, 60% RH	<b>6dB Bandwidth</b>	9 kHz
<b>Test Date</b>	2020/10/21	<b>Phase</b>	N
<b>Tested by</b>	Guanwei Liao	<b>Test Site</b>	W01

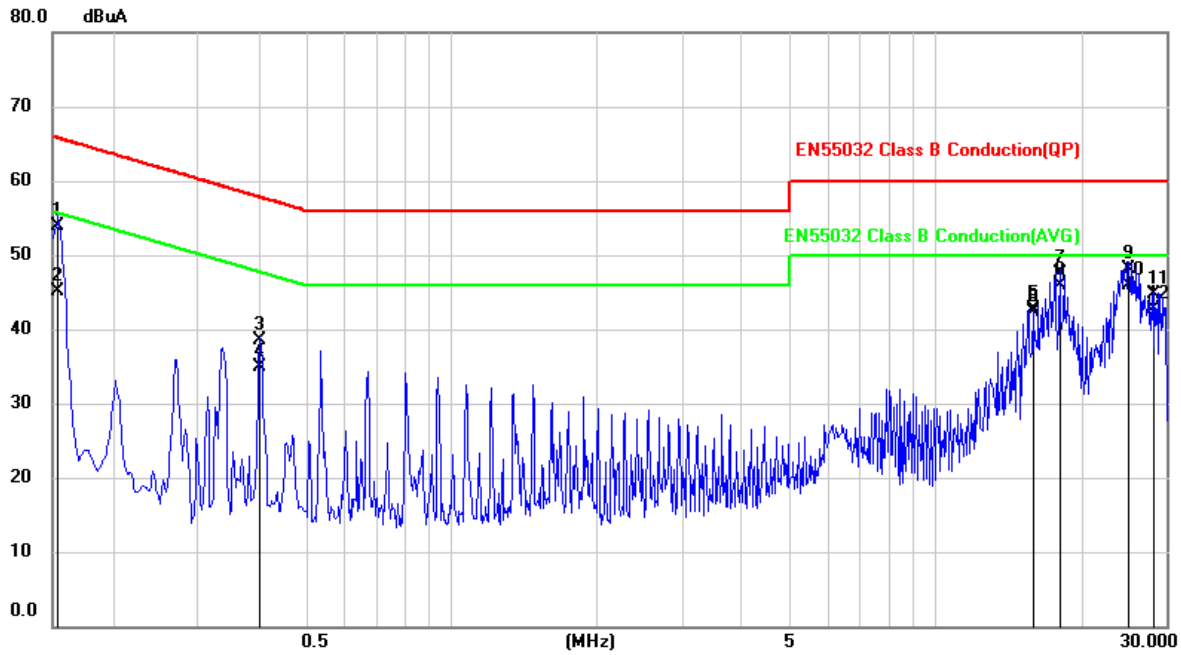

No.	Frequency (MHz)	Reading Level (dBuV)	Correct Factor (dB)	Measurement (dBuV)	Limit (dBuV)	Margin (dB)	Detector
1	0.1538	43.96	9.99	53.95	65.79	-11.84	QP
2	0.1538	35.08	9.99	45.07	55.79	-10.72	AVG
3	0.4038	28.57	9.99	38.56	57.77	-19.21	QP
4	0.4038	24.90	9.99	34.89	47.77	-12.88	AVG
5	15.9325	32.48	10.19	42.67	60.00	-17.33	QP
6	15.9325	32.09	10.19	42.28	50.00	-7.72	AVG
7	18.0421	37.20	10.21	47.41	60.00	-12.59	QP
8	18.0421	35.76	10.21	45.97	50.00	-4.03	AVG
9	25.1467	37.78	10.26	48.04	60.00	-11.96	QP
10	25.1467	35.71	10.26	45.97	50.00	-4.03	AVG
11	28.4062	34.35	10.30	44.65	60.00	-15.35	QP
12	28.4062	32.36	10.30	42.66	50.00	-7.34	AVG

**Remark:** 1. QP = Quasi Peak, AVG = Average  
 2. Correction Factor = Insertion loss of LISN + Cable loss + Transient Limiter (If use)  
 3. Measurement Value = Reading Level + Correct Factor  
 4. Margin Level = Measurement Value - Limit Value



<b>Test Voltage</b>	110Vac, 60Hz	<b>Frequency Range</b>	0.15-30 MHz
<b>Environmental Conditions</b>	24°C, 60% RH	<b>6dB Bandwidth</b>	9 kHz
<b>Test Date</b>	2020/10/21	<b>Phase</b>	L
<b>Tested by</b>	Guanwei Liao	<b>Test Site</b>	W01

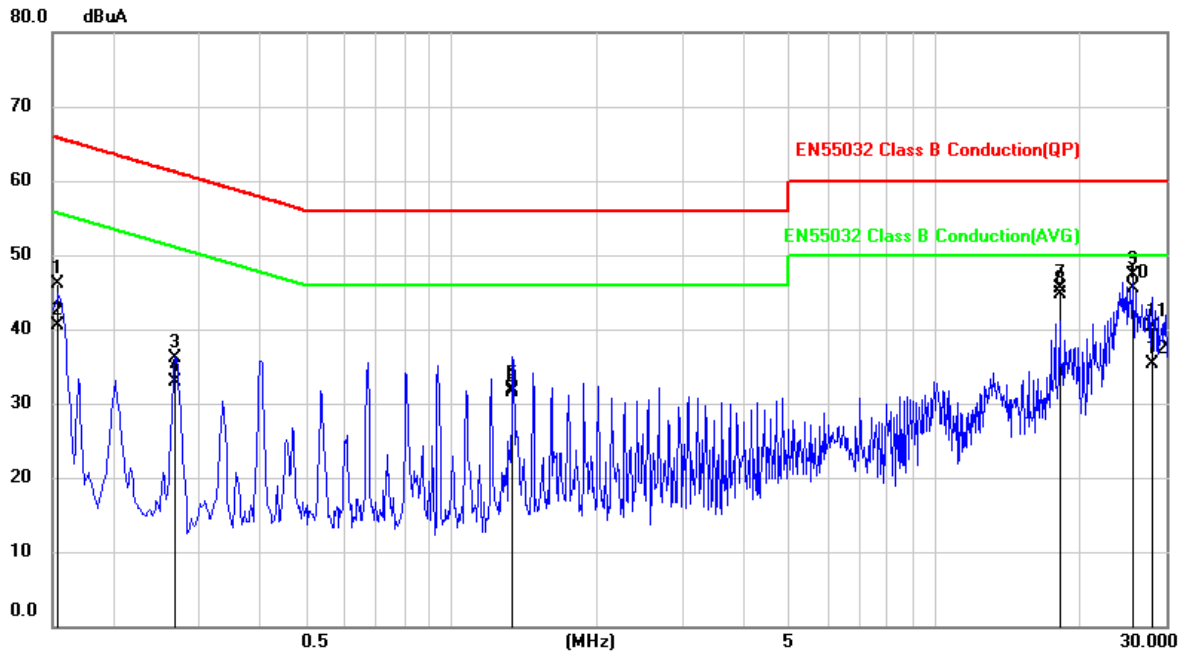

No.	Frequency (MHz)	Reading Level (dBuV)	Correct Factor (dB)	Measurement (dBuV)	Limit (dBuV)	Margin (dB)	Detector
1	0.1532	36.09	10.02	46.11	65.82	-19.71	QP
2	0.1532	30.41	10.02	40.43	55.82	-15.39	AVG
3	0.2691	26.11	10.02	36.13	61.15	-25.02	QP
4	0.2691	22.98	10.02	33.00	51.15	-18.15	AVG
5	1.3444	21.83	10.07	31.90	56.00	-24.10	QP
6	1.3444	21.48	10.07	31.55	46.00	-14.45	AVG
7	18.0819	34.98	10.49	45.47	60.00	-14.53	QP
8	18.0819	34.27	10.49	44.76	50.00	-5.24	AVG
9	25.5823	36.68	10.62	47.30	60.00	-12.70	QP
10	25.5823	34.97	10.62	45.59	50.00	-4.41	AVG
11	28.0848	29.71	10.68	40.39	60.00	-19.61	QP
12	28.0848	24.60	10.68	35.28	50.00	-14.72	AVG

**Remark:**

1. QP = Quasi Peak, AVG = Average
2. Correction Factor = Insertion loss of LISN + Cable loss + Transient Limiter (If use)
3. Measurement Value = Reading Level + Correct Factor
4. Margin Level = Measurement Value - Limit Value



<b>Test Voltage</b>	110Vac, 60Hz	<b>Frequency Range</b>	0.15-30 MHz
<b>Environmental Conditions</b>	24°C, 60% RH	<b>6dB Bandwidth</b>	9 kHz
<b>Test Date</b>	2020/10/21	<b>Phase</b>	N
<b>Tested by</b>	Guanwei Liao	<b>Test Site</b>	W01

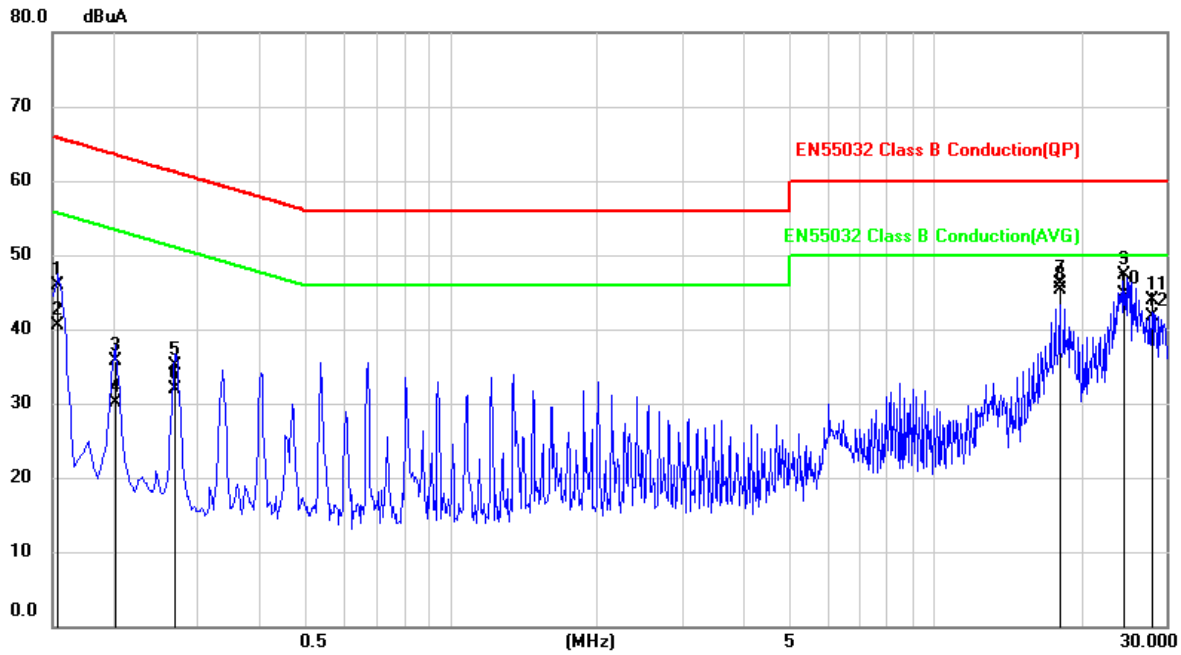

No.	Frequency (MHz)	Reading Level (dBuV)	Correct Factor (dB)	Measurement (dBuV)	Limit (dBuV)	Margin (dB)	Detector
1	0.1543	35.98	9.99	45.97	65.77	-19.80	QP
2	0.1543	30.42	9.99	40.41	55.77	-15.36	AVG
3	0.2023	25.68	9.99	35.67	63.52	-27.85	QP
4	0.2023	20.16	9.99	30.15	53.52	-23.37	AVG
5	0.2686	25.06	9.99	35.05	61.16	-26.11	QP
6	0.2686	21.94	9.99	31.93	51.16	-19.23	AVG
7	18.0643	35.93	10.21	46.14	60.00	-13.86	QP
8	18.0643	35.14	10.21	45.35	50.00	-4.65	AVG
9	24.7891	36.96	10.26	47.22	60.00	-12.78	QP
10	24.7891	34.43	10.26	44.69	50.00	-5.31	AVG
11	28.0509	33.56	10.29	43.85	60.00	-16.15	QP
12	28.0509	31.49	10.29	41.78	50.00	-8.22	AVG

**Remark:**

1. QP = Quasi Peak, AVG = Average
2. Correction Factor = Insertion loss of LISN + Cable loss + Transient Limiter (If use)
3. Measurement Value = Reading Level + Correct Factor
4. Margin Level = Measurement Value - Limit Value

### 4.1.7 Photographs of Test Configuration

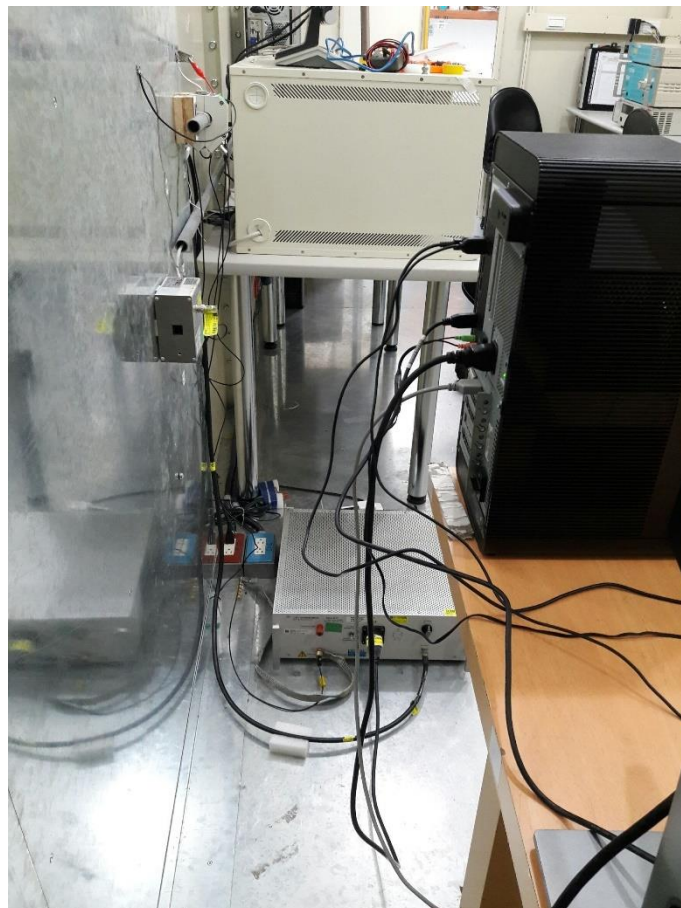



## **4.2 Conducted Emission at Telecommunication Ports Test**

The test is determined no necessary for the EUT do not operate from the telecom lines or contain provisions for operation while connected to the telecom lines.

### 4.3 Radiated Emission Measurement

#### 4.3.1 Limits of Radiated Emission Measurement

According to EN 55032 table1 - Required highest frequency for radiated measurement:

Highest internal frequency ( $F_x$ )	Highest measured frequency
$F_x \leq 108$ MHz	1 GHz
$108$ MHz $< F_x \leq 500$ MHz	2 GHz
$500$ MHz $< F_x \leq 1$ GHz	5 GHz
$F_x > 1$ GHz	$5 \times F_x$ up to a maximum of 6 GHz

Remark:

1.  $F_x$  : highest fundamental frequency generated or used within the EUT or highest frequency at which it operates.
2. Where  $F_x$  is unknown, the radiated emission measurements shall be performed up to 6 GHz.

Class A equipment:

Requirements for radiated emissions at frequencies up to 1 GHz for Class A equipment			
Frequency (MHz)	Measurement		Class A limits dB(uV/m)
	Distance (m)	Detector type/ bandwidth	OATS/SAC
30 to 230	10	Quasi Peak / 120 kHz	40
230 to 1000			47
30 to 230	3		50
230 to 1000			57

Requirements for radiated emissions at frequencies above 1 GHz for Class A equipment			
Frequency (MHz)	Measurement		Class A limits dB(uV/m)
	Distance (m)	Detector type/ bandwidth	FSOATS
1000 to 3000	3	Average / 1 MHz	56
3000 to 6000			60
1000 to 3000		Peak / 1 MHz	76
3000 to 6000			80



Class B equipment:

Requirements for radiated emissions at frequencies up to 1 GHz for Class B equipment			
Frequency (MHz)	Measurement		Class B limits dB(uV/m)
	Distance (m)	Detector type/ bandwidth	OATS/SAC
30 to 230	10	Quasi Peak / 120 kHz	30
230 to 1000			37
30 to 230	3		40
230 to 1000			47

Requirements for radiated emissions at frequencies above 1 GHz for Class B equipment			
Frequency (MHz)	Measurement		Class B limits dB(uV/m)
	Distance (m)	Detector type/ bandwidth	FSOATS
1000 to 3000	3	Average / 1 MHz	50
3000 to 6000			54
1000 to 3000		Peak / 1 MHz	70
3000 to 6000			74

- Note:**
1. The lower limit shall apply at the transition frequency.
  2. Detector function in the form: PK = Peak, QP = Quasi Peak, AV = Average
  3. The test result calculated as following:  
 Measurement Value = Reading Level + Correct Factor  
 Correction Factor = Antenna factor + Cable loss (Antenna to preamplifier) - preamplifier Gain  
 + Cable loss (preamplifier to receiver)  
 Margin Level = Measurement Value - Limit Value



### 4.3.2 Test Instrument

Test Site: W08-966					
Item	Equipment	Manufacturer	Model	Meter No.	Calibration Date
1	Horn Antenna	Schwarzbeck	BBHA 9120D	CT-9-031	Jul. 28, 2020
2	Horn Antenna	Schwarzbeck	BBHA 9170	CT-9-032	Dec. 04, 2019
3	TRILOG Broadband Antenna with 5 dB Attenuator	Schwarzbeck	VULB 9168 & FAT-NM5NF5T3G 2W5	CT-1-002-1	Jul. 29, 2020
4	EXA Signal Analyzer	Keysight	N9010A	CT-1-093	Apr. 21, 2020
5	EMI Test Receiver	Keysight	N9038A	CT-9-007	Jul. 28, 2020
6	Preamplifier	EM	EM 330	CT-9-024	Jul. 30, 2020
7	Preamplifier	JPT	JPA0118-55-303K	CT-1-139	Apr. 21, 2020
8	Preamplifier	EMCI	EMC051845SE	CT-9-012	Sep. 04, 2020
9	Preamplifier	EMCI	EMC184045SE	CT-9-013	Sep. 04, 2020
10	Test Cable	EMCI	EMCCFD400-NM-NM-1000	CT-1-132	Jul. 29, 2020
11	Test Cable	PEWC	CFD400NL-LW-N M-NM-3000	CT-1-141	Jul. 30, 2020
12	Test Cable	EMCI	EMCCFD400-NM-NM-15000	CT-1-133	Jul. 30, 2020
13	Test Cable	EMCI	EMC104-SM-35M-600	CT-1-134	Jul. 30, 2020
14	Test Cable	EMCI	EMC104-SM-35M-15000	CT-1-135	Jul. 30, 2020
15	Test Cable	EMCI	EMC102-KM-KM-600	CT-1-136	Jul. 30, 2020
16	Test Cable	MVE	140140.LL404.700	CT-9-066	Apr. 21, 2020
17	Measurement Software	EZ-EMC	Ver : FA-03A2 RE	CT-3-012	No calibration request

**Note:** 1. The calibration interval of the above test instruments is 12 months.

### 4.3.3 Test Procedure

- a. The table-top EUT was placed on the top of a turntable 0.8 meters above the ground at 3 m 966 chamber. The floor-standing EUT was placed insulation support unit from the horizontal ground plane. The table was rotated 360 degrees to determine the position of the high radiation emissions.
- b. The height of the test antenna shall vary between 1 m to 4 m. Both vertical and horizontal polarizations of the antenna were set to make the measurement.
- c. The EUT was set up as per the test configuration to simulate typical usage per the user's manual. All I/O cables were positioned to simulate typical usage. The actual test configuration, please refer to EUT test photos.
- d. The initial step in collecting radiated emission data is a Spectrum Mode scanning the measurement frequency range.

#### **Below 1GHz:**

Reading in which marked as QP or Peak means measurements by using Spectrum Mode with detector RBW=120kHz.

If the Spectrum Mode measured peak value compliance with and lower than Quasi Peak Limit, the EUT shall be deemed to meet QP Limits.

#### **Above 1GHz:**

Reading in which marked as Peak & AVG means measurements by using Spectrum Mode with setting in RBW=1MHz.

If the Spectrum Mode measured value compliance with the Peak Limits and lower than AVG Limits, the EUT shall be deemed to meet both Peak and AVG Limits.

- e. Emission frequency and amplitude were recorded, recording at least six highest emissions. The EUT and cable configuration of the above highest emission levels were recorded. The test data of the worst case was recorded.

### 4.3.4 Deviation from Test Standard

No deviation

### 4.3.5 Test Setup

< Radiated Emissions Frequency: 30 MHz to 1000 MHz >

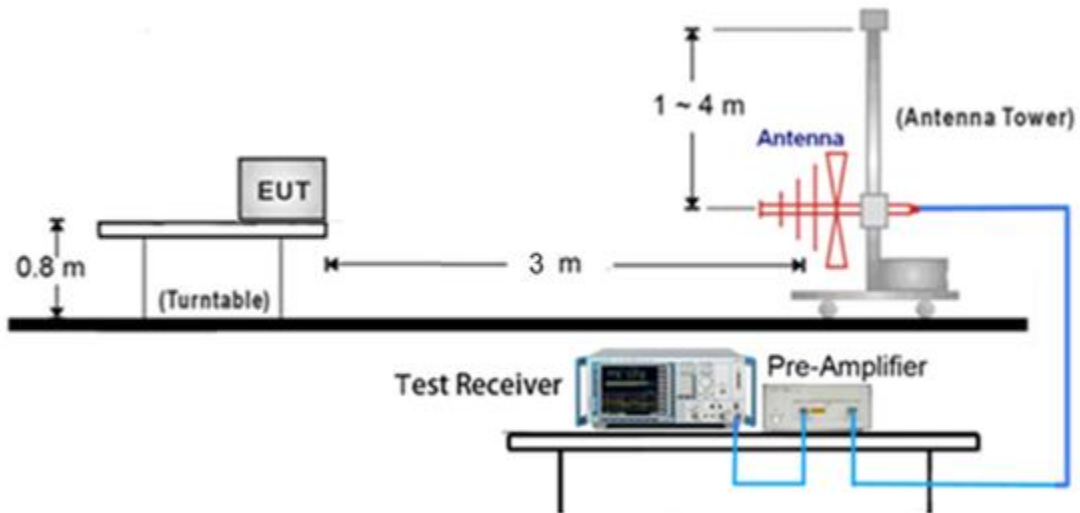

< Radiated Emissions Frequency: above 1GHz >

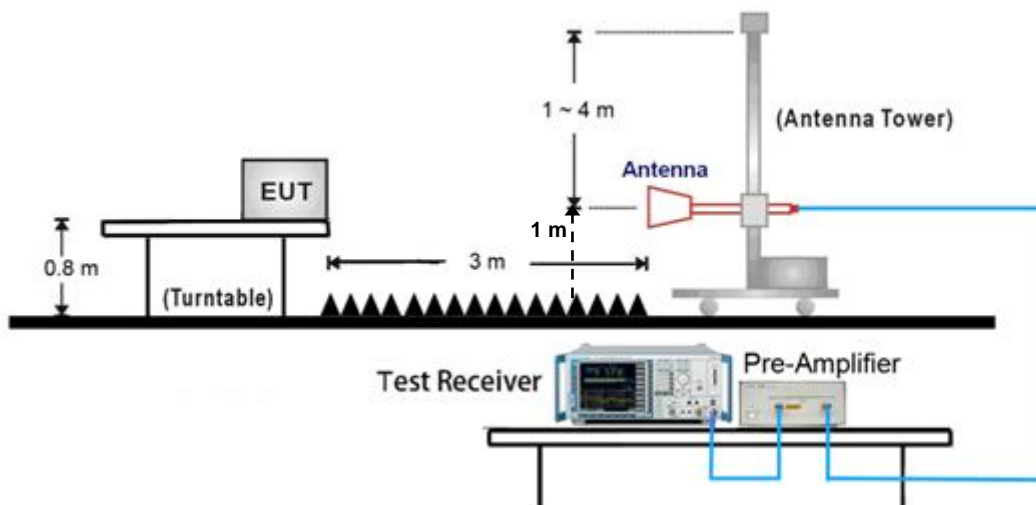

**Note:**

- (1) Please refer to the 4.3.7 for the actual test configuration.
- (2) The formula of measured value as:  $\text{Test Result} = \text{Reading} + \text{Correction Factor}$
- (3) Detector function in the form: PK = Peak, QP = Quasi Peak, AV = Average
- (4) The test result calculated as following:  
 $\text{Measurement Value} = \text{Reading Level} + \text{Correct Factor}$   
 $\text{Correct Factor} = \text{Antenna Factor} + \text{Cable Loss} - \text{Amplifier Gain (if use)}$   
 $\text{Margin Level} = \text{Measurement Value} - \text{Limit Value}$

< EUT placement top view and measurement distance >

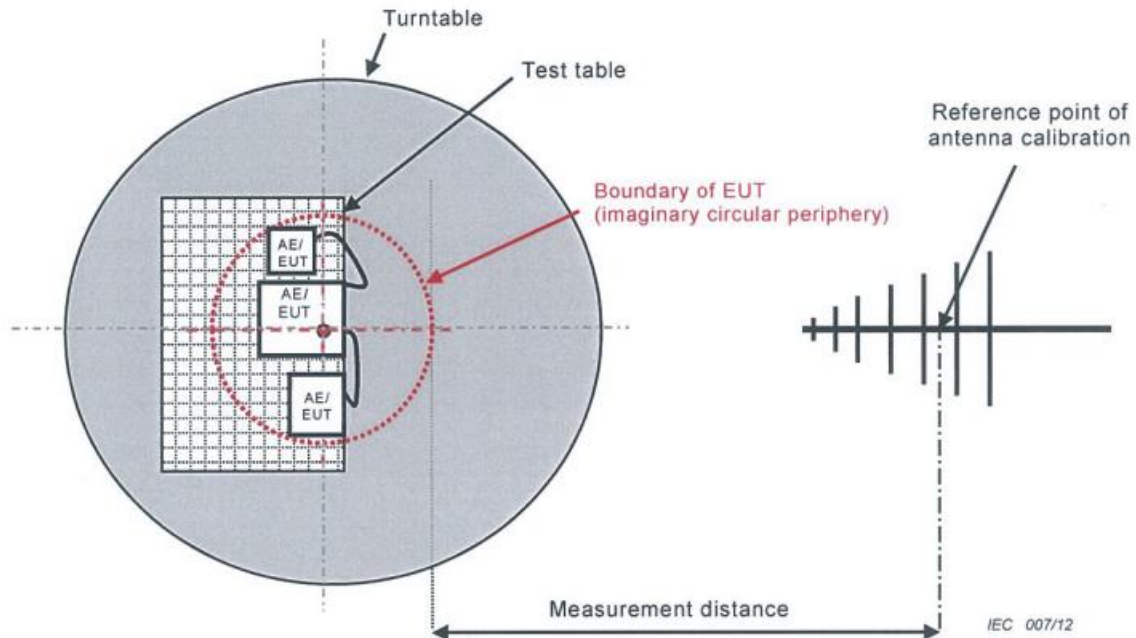

< Boundary of EUT, Local AE and associated cabling >

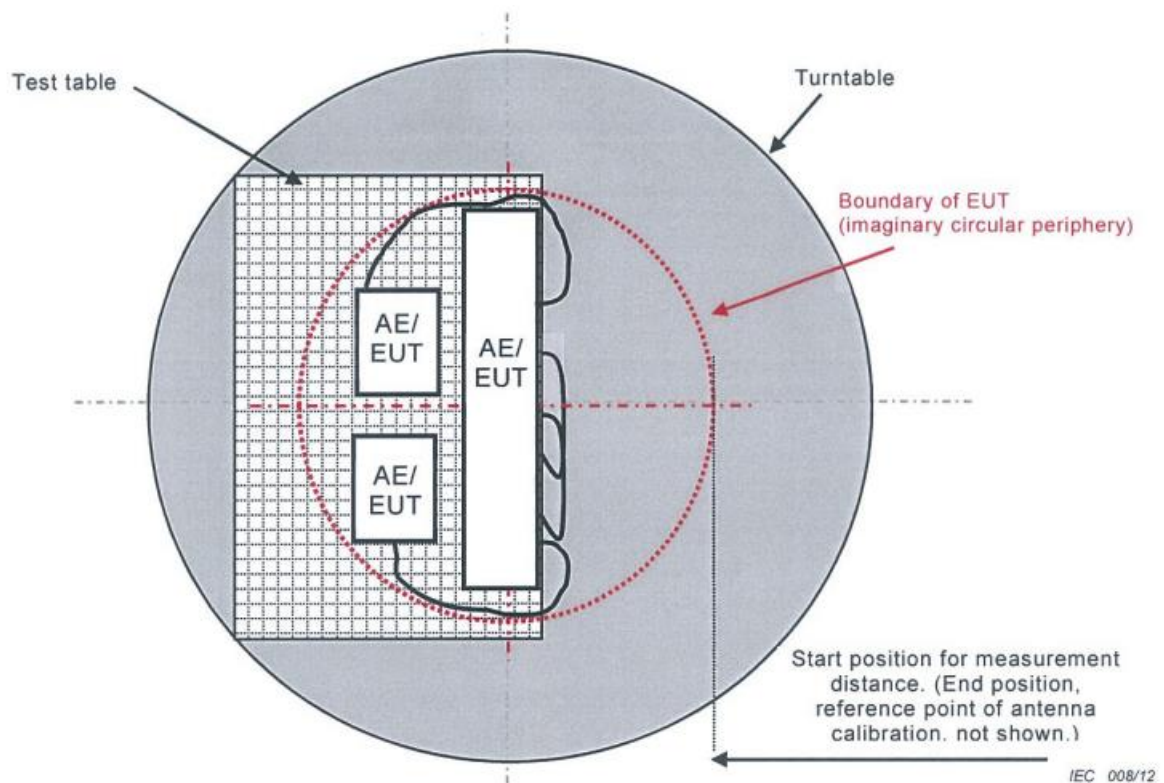

< Table-Top equipment >

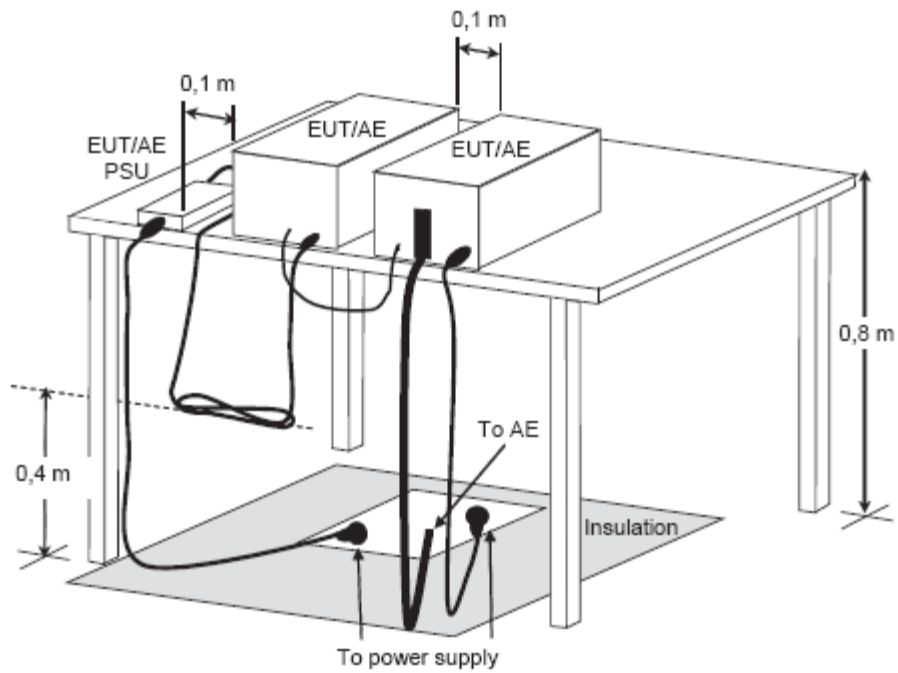

< Floor-Standing equipment >

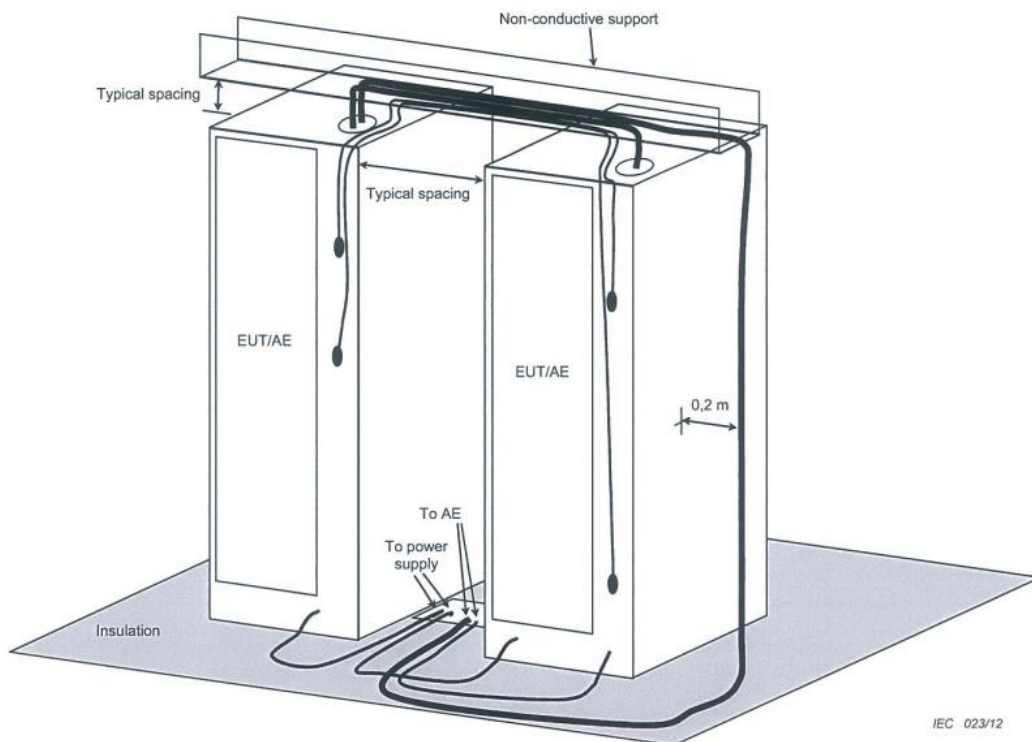

IEC 023/12

**Note:** Please refer to the 4.3.7 for the actual test configuration.



### 4.3.6 Test Result

Test Voltage	230Vac, 50Hz	Frequency Range	30 – 1000 MHz
Environmental Conditions	23°C, 58% RH	6dB Bandwidth	120 kHz
Test Date	2020/10/22	Test Distance	3m
Tested by	Karwin Kao	Polarization	Vertical
Test Site	W08		

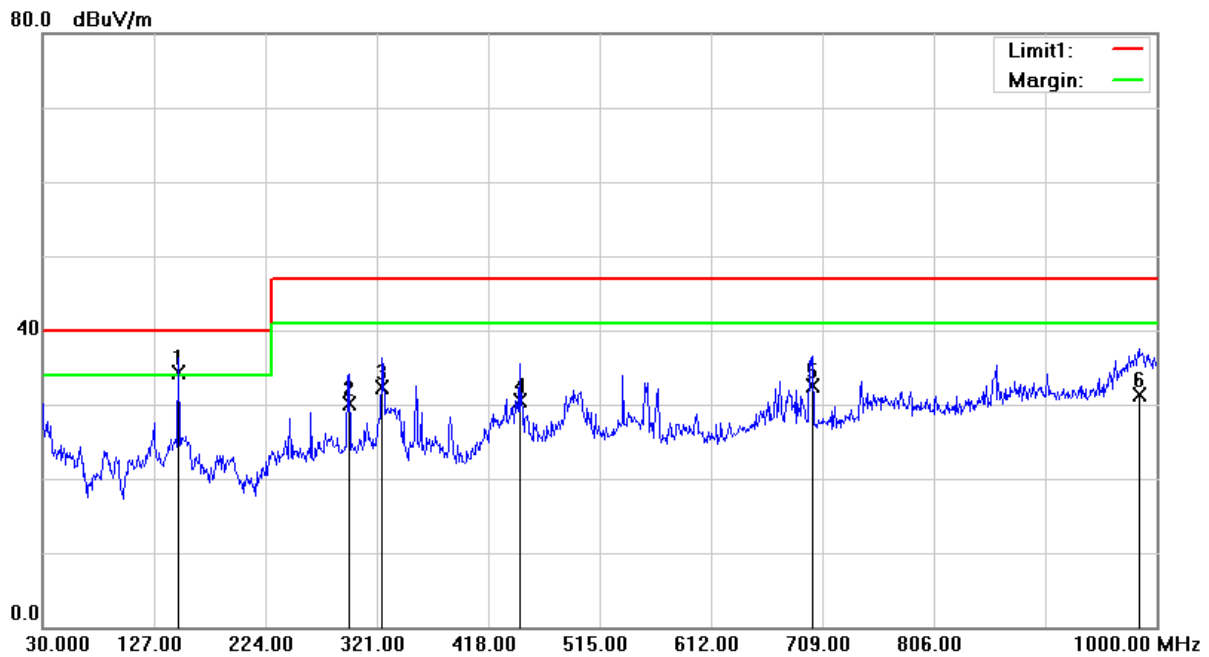

No.	Frequency (MHz)	Reading Level (dBuV)	Correct Factor (dB/m)	Measurement (dBuV/m)	Limit (dBuV/m)	Margin (dB)	Table Degree (degree)	Antenna Height (cm)	Detector
1	148.3400	43.48	-9.21	34.27	40.00	-5.73	302	100	QP
2	296.7500	38.06	-8.01	30.05	47.00	-16.95	172	100	QP
3	325.8500	39.84	-7.61	32.23	47.00	-14.77	128	100	QP
4	445.1600	35.35	-4.88	30.47	47.00	-16.53	178	100	QP
5	700.2700	32.76	-0.33	32.43	47.00	-14.57	355	100	QP
6	984.4800	26.88	4.52	31.40	47.00	-15.60	178	100	QP

- Remark:**
1. QP = Quasi Peak
  2. Correction Factor = Antenna factor + Cable loss (Antenna to preamplifier ) - preamplifier Gain + Cable loss (preamplifier to receiver )
  3. Measurement Value = Reading Level + Correct Factor
  4. Margin Level = Measurement Value - Limit Value



<b>Test Voltage</b>	230Vac, 50Hz	<b>Frequency Range</b>	30 – 1000 MHz
<b>Environmental Conditions</b>	23°C, 58% RH	<b>6dB Bandwidth</b>	120 kHz
<b>Test Date</b>	2020/10/22	<b>Test Distance</b>	3m
<b>Tested by</b>	Karwin Kao	<b>Polarization</b>	Horizontal
<b>Test Site</b>	W08		

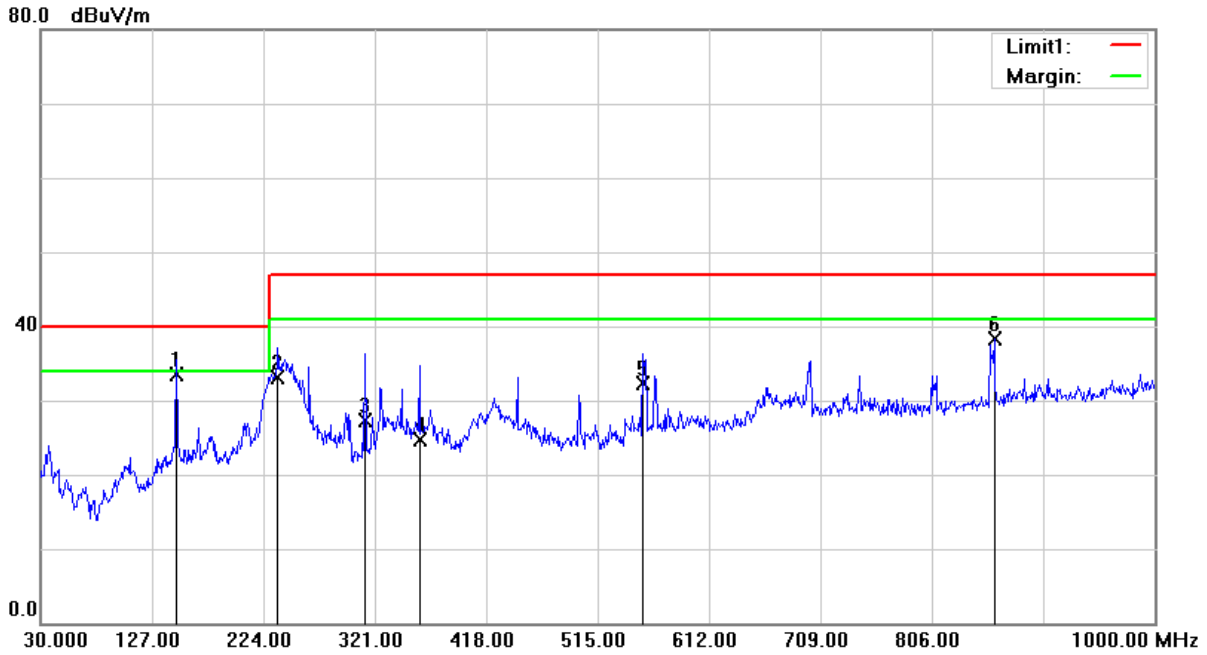

No.	Frequency (MHz)	Reading Level (dBuV)	Correct Factor (dB/m)	Measurement (dBuV/m)	Limit (dBuV/m)	Margin (dB)	Table Degree (degree)	Antenna Height (cm)	Detector
1	148.3400	42.64	-9.21	33.43	40.00	-6.57	265	200	QP
2	236.6100	41.83	-8.81	33.02	47.00	-13.98	171	100	QP
3	312.2700	35.28	-7.90	27.38	47.00	-19.62	221	100	QP
4	359.8000	31.70	-6.94	24.76	47.00	-22.24	360	103	QP
5	553.8000	35.15	-2.81	32.34	47.00	-14.66	177	100	QP
6	860.3200	35.68	2.53	38.21	47.00	-8.79	201	100	QP

- Remark:**
1. QP = Quasi Peak
  2. Correction Factor = Antenna factor + Cable loss (Antenna to preamplifier ) - preamplifier Gain + Cable loss (preamplifier to receiver )
  3. Measurement Value = Reading Level + Correct Factor
  4. Margin Level = Measurement Value - Limit Value



<b>Test Voltage</b>	230Vac, 50Hz	<b>Frequency Range</b>	1 – 6GHz
<b>Environmental Conditions</b>	23°C, 58% RH	<b>6dB Bandwidth</b>	1MHz
<b>Test Date</b>	2020/10/22	<b>Test Distance</b>	3m
<b>Tested by</b>	Karwin Kao	<b>Polarization</b>	Vertical
<b>Test Site</b>	W08		

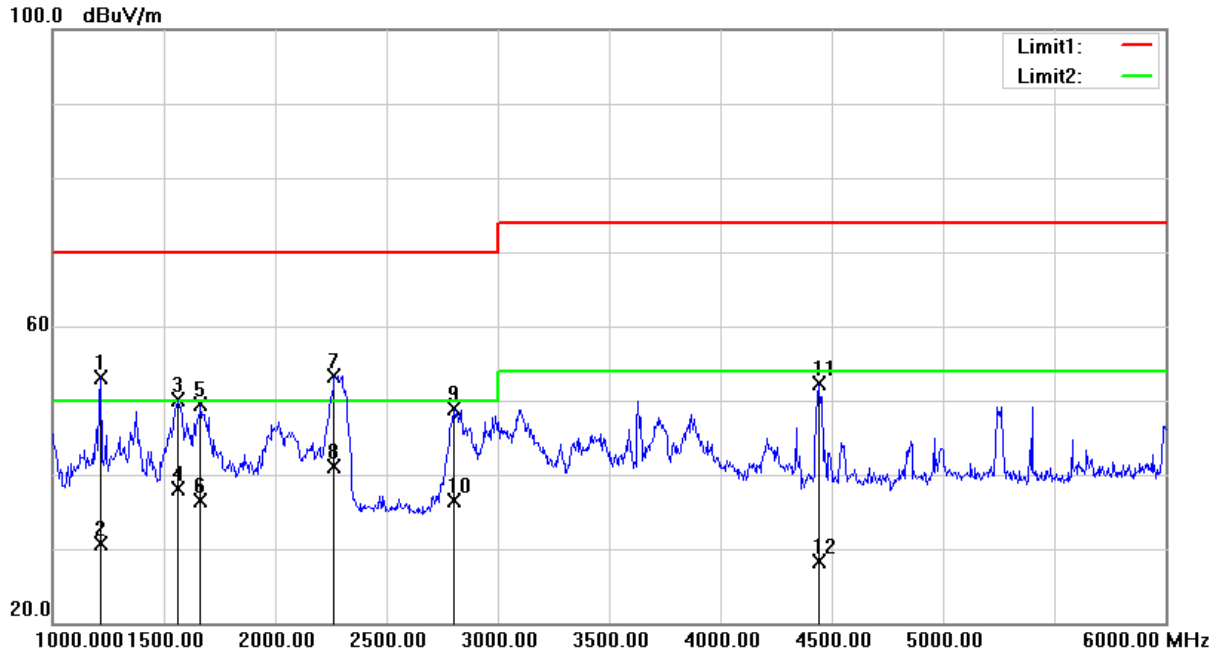

No.	Frequency (MHz)	Reading Level (dBuV)	Correct Factor (dB/m)	Measurement (dBuV/m)	Limit (dBuV/m)	Margin (dB)	Table Degree (degree)	Antenna Height (cm)	Detector
1	1215.000	83.31	-30.28	53.03	70.00	-16.97	211	100	peak
2	1215.000	60.95	-30.28	30.67	50.00	-19.33	211	100	AVG
3	1565.000	81.29	-31.25	50.04	70.00	-19.96	155	100	peak
4	1565.000	69.26	-31.25	38.01	50.00	-11.99	155	100	AVG
5	1665.000	80.79	-31.30	49.49	70.00	-20.51	211	100	peak
6	1665.000	67.89	-31.30	36.59	50.00	-13.41	211	100	AVG
7	2265.000	78.76	-25.37	53.39	70.00	-16.61	197	100	peak
8	2265.000	66.43	-25.37	41.06	50.00	-8.94	197	100	AVG
9	2805.000	73.77	-24.96	48.81	70.00	-21.19	131	100	peak
10	2805.000	61.43	-24.96	36.47	50.00	-13.53	131	100	AVG
11	4440.000	72.15	-19.75	52.40	74.00	-21.60	347	100	peak
12	4440.000	48.15	-19.75	28.40	54.00	-25.60	347	100	AVG

**Remark:** 1. peak = Peak, AVG = Average  
 2. Correction Factor = Antenna factor + Cable loss (Antenna to preamplifier) - preamplifier Gain + Cable loss (preamplifier to receiver)  
 3. Measurement Value = Reading Level + Correct Factor  
 4. Margin Level = Measurement Value - Limit Value



<b>Test Voltage</b>	230Vac, 50Hz	<b>Frequency Range</b>	1 – 6GHz
<b>Environmental Conditions</b>	23°C, 58% RH	<b>6dB Bandwidth</b>	1MHz
<b>Test Date</b>	2020/10/22	<b>Test Distance</b>	3m
<b>Tested by</b>	Karwin Kao	<b>Polarization</b>	Horizontal
<b>Test Site</b>	W08		

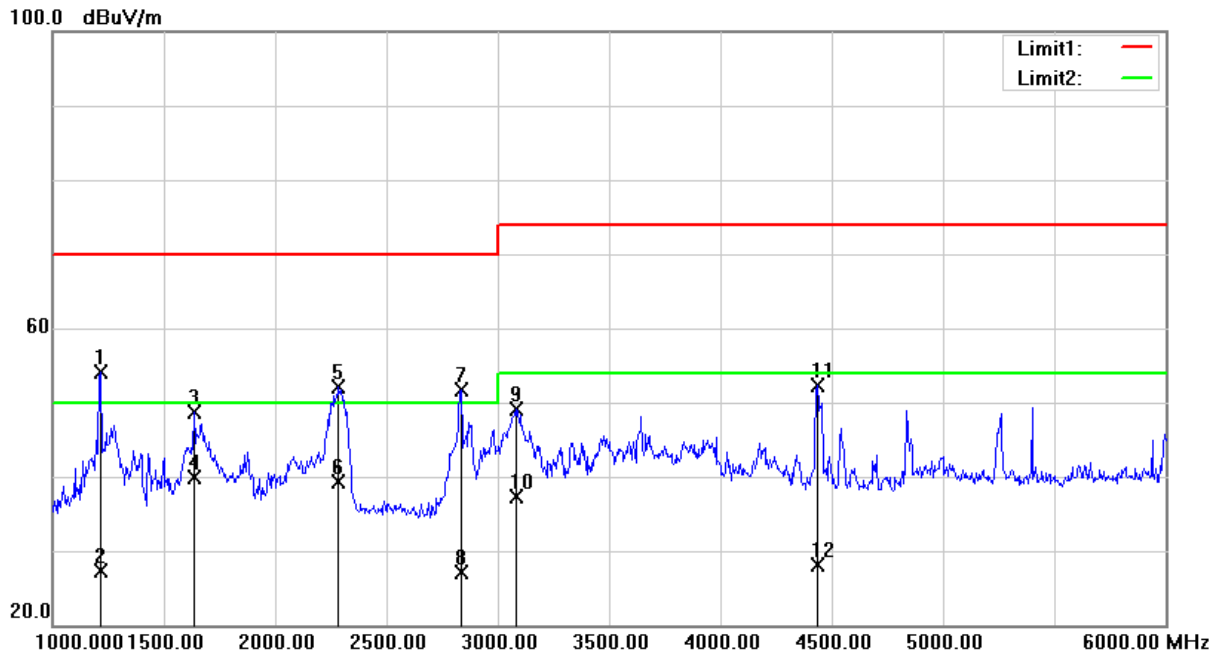

No.	Frequency (MHz)	Reading Level (dBuV)	Correct Factor (dB/m)	Measurement (dBuV/m)	Limit (dBuV/m)	Margin (dB)	Table Degree (degree)	Antenna Height (cm)	Detector
1	1215.000	84.35	-30.28	54.07	70.00	-15.93	60	100	peak
2	1215.000	57.54	-30.28	27.26	50.00	-22.74	60	100	AVG
3	1635.000	79.98	-31.30	48.68	70.00	-21.32	124	100	peak
4	1635.000	71.11	-31.30	39.81	50.00	-10.19	124	100	AVG
5	2285.000	76.91	-24.90	52.01	70.00	-17.99	158	100	peak
6	2285.000	64.20	-24.90	39.30	50.00	-10.70	158	100	AVG
7	2835.000	76.66	-24.87	51.79	70.00	-18.21	1	100	peak
8	2835.000	52.03	-24.87	27.16	50.00	-22.84	1	100	AVG
9	3080.000	73.69	-24.52	49.17	74.00	-24.83	110	100	peak
10	3080.000	61.86	-24.52	37.34	54.00	-16.66	110	100	AVG
11	4435.000	72.11	-19.78	52.33	74.00	-21.67	225	100	peak
12	4435.000	47.98	-19.78	28.20	54.00	-25.80	225	100	AVG

**Remark:**

1. peak = Peak, AVG = Average
2. Correction Factor = Antenna factor + Cable loss (Antenna to preamplifier) - preamplifier Gain + Cable loss (preamplifier to receiver)
3. Measurement Value = Reading Level + Correct Factor
4. Margin Level = Measurement Value - Limit Value

### 4.3.7 Photographs of Test Configuration

#### Radiated Emission Test (30MHz~1GHz)



**Radiated Emission Test (Above 1GHz)**





#### **4.4 Harmonics Current Measurement**

The test is determined no necessary for the EUT do not operate from the AC main power lines or contain provisions for operation while connected to the AC main power lines.



#### **4.5 Voltage Fluctuation and Flicker Measurement**

The test is determined no necessary for the EUT do not operate from the AC main power lines or contain provisions for operation while connected to the AC main power lines.

## 5 Immunity Test

### 5.1 Standard Description

Product standard	EN 55035	
<b>Basic Standard and Performance Criterion required</b>	IEC 61000-4-2 (ESD)	±4 kV Contact discharge, ±8 kV Air discharge, Performance Criterion B
	IEC 61000-4-3 (RS)	80 M ~ 1000 MHz, 3V/m(rms) , 80% AM (1kHz), 1800 MHz, 2600 MHz, 3500 MHz, 5000 MHz for spot test (Wireless communication device), 3V/m(rms), 80% AM (1kHz), Performance Criterion A
	IEC 61000-4-4 (EFT)	AC Main Power Port: ±1kV, DC Network Power Port (cable length > 3m): ±0.5 kV, Analogue/Digital Data Ports (cable length > 3m): ±0.5 kV, Performance Criterion B
	IEC 61000-4-5 (Surge)	AC Main Power Port: line to line ±1 kV, line to ground ±2 kV, DC Network Power Port (cable length > 3m): line to ground ±0.5 kV, Performance Criteria B Analogue/Digital Data Ports (unshielded symmetrical):line to ground Primary Protection: Intended, ±1 kV and ±4 kV, Primary Protection: Not Intended, ±1 kV, Performance Criteria C Analogue/Digital Data Ports (coaxial or shielded): shielded to ground, ±0.5 kV, Performance Criteria B
	IEC 61000-4-6 (CS)	AC Main Power Port, DC Network Power Port (cable length > 3m), Analogue/Digital Data Ports (cable length > 3m), 0.15 M ~ 10 MHz, 3Vrms, 80% AM, 1kHz, 10 M ~ 30 MHz, 3 - 1Vrms, 80% AM, 1kHz, 30 M ~ 80 MHz, 1Vrms, 80% AM, 1kHz, Performance Criterion A
	IEC 61000-4-8 (PFMF)	50Hz or 60Hz, 1 A/m, Performance Criterion A
	IEC 61000-4-11 (Dips)	Voltage Dips: >95% reduction, 0.5 period, Performance Criterion B 30% reduction, 25 period, Performance Criterion C Voltage Interruptions: >95% reduction, 250 period, Performance Criterion C

## 5.2 Performance Criteria

According to Clause 8 of EN 55035 standard, the general performance criteria as following:

<b>Criteria A</b>	The equipment shall continue to operate as intended without operator intervention. No degradation of performance, loss of function or change of operating state is allowed below a performance level specified by the manufacturer when the equipment is used as intended. The performance level may be replaced by a permissible loss of performance. If the minimum performance level or the permissible performance loss is not specified by the manufacturer, then either of these may be derived from the product description and documentation, and by what the user may reasonably expect from the equipment if used as intended.
<b>Criteria B</b>	During the application of the disturbance, degradation of performance is allowed. However, no unintended change of actual operating state or stored data is allowed to persist after the test. After the test, the equipment shall continue to operate as intended without operator intervention. No degradation of performance or loss of function is allowed, below a performance level specified by the manufacturer, when the equipment is used as intended. The performance level may be replaced by a permissible loss of performance. If the minimum performance level (or the permissible performance loss), or recovery time is not specified by the manufacturer, then either of these may be derived from the product description and documentation, and by what the user may reasonably expect from the equipment if used as intended.
<b>Criteria C</b>	Loss of function is allowed, provided the function is self-recoverable, or can be restored by the operation of the controls by the user in accordance with the manufacturer's instructions. A reboot or re-start operation is allowed. Information stored in non-volatile memory, or protected by a battery backup, shall not be lost.

## 5.3 Electrostatic Discharge (ESD)

### 5.3.1 Test Specification

<b>Standard</b>	IEC/EN 61000-4-2
<b>Discharge Impedance</b>	330 ohm / 150 pF
<b>Discharge Voltage</b>	Air Discharge: $\pm 2, \pm 4, \pm 8$ kV (Direct) Contact Discharge: $\pm 4$ kV (Direct/Indirect)
<b>Number of Discharge</b>	Air: Minimum 10 times at each point. Contact: Minimum 25 times at each point and minimum 200 times in total
<b>Discharge Mode</b>	Single Discharge
<b>Discharge Period</b>	1 second minimum

### 5.3.2 Test Instrument

Item	Equipment	Manufacturer	Model	Meter No.	Calibration Date
1	ESD Generator	TESEQ	NSG 437	CT-1-140	Sep. 16, 2020
2	ESD Generator	NoiseKen	ESS-B3011	CT-1-089	Aug. 26, 2020
3	ESD Simulator/ Discharge Gun	NoiseKen	ESS-2002 & TC-815R	CT-1-010(1)	Sep. 02, 2020
4	Digital Thermo-Hygro Meter	N/A	HTC-8	CT-2-047	Apr. 23, 2019
5	Atmosphere pressure meter	TES	TES-1161	CT-5-094	Aug. 20, 2019

**Note:** 1. The calibration interval of the test instruments is 12 months.

2. The calibration interval of thermo hygrometer/ Atmosphere pressure meter is 24 months.

### 5.3.3 Test Procedure

The test generator necessary to perform direct and indirect application of discharge to the EUT in following methods:

a. Contact discharges to the conductive surface and coupling planes:

The EUT shall be exposed to at least 200 discharges, 100 each at negative and positive polarity, at a minimum of four test points. For table-top equipment one of the test points shall be the centre front edge of the horizontal coupling plane, which shall be subjected to at least 50 indirect discharges (25 of each polarity). All other test points shall each receive at least 50 direct contact discharges (25 of each polarity). All areas normally touched by the user should be tested. If no direct contact test points are available, shall be at least 200 indirect discharges shall be applied in the indirect mode. Test shall be performed at a maximum repetition rate of one discharge per second.

**Vertical Coupling Plane (VCP):**

The coupling plane, of dimensions 0.5 m × 0.5 m, is placed parallel to, and positioned at a distance 0.1 m from, the EUT, with the discharge electrode touching the coupling plane. The four faces of the EUT will be performed with electrostatic discharge.

**Horizontal Coupling Plane (HCP):**

The coupling plane, of dimensions 1.6 m × 0.8 m, is placed under the EUT. The generator shall be positioned vertically a distance of 0.1 m from the EUT, with the discharge electrode touching the coupling plane. The four faces of the EUT will be performed with electrostatic discharge.

b. Air discharge at apertures and slots and insulating surface:

On those parts of the EUT where it is not possible to perform contact discharge testing, the equipment should be investigated to identify user accessible points where breakdown may occur. Such points are tested using the air discharge method. This investigation should be restricted to those area normally handled by the user. A minimum 10 single air discharges shall be applied to the selected test point for each such area.

### 5.3.4 Deviation from Test Standard

No deviation

### 5.3.5 Test Setup

< Table-Top equipment >

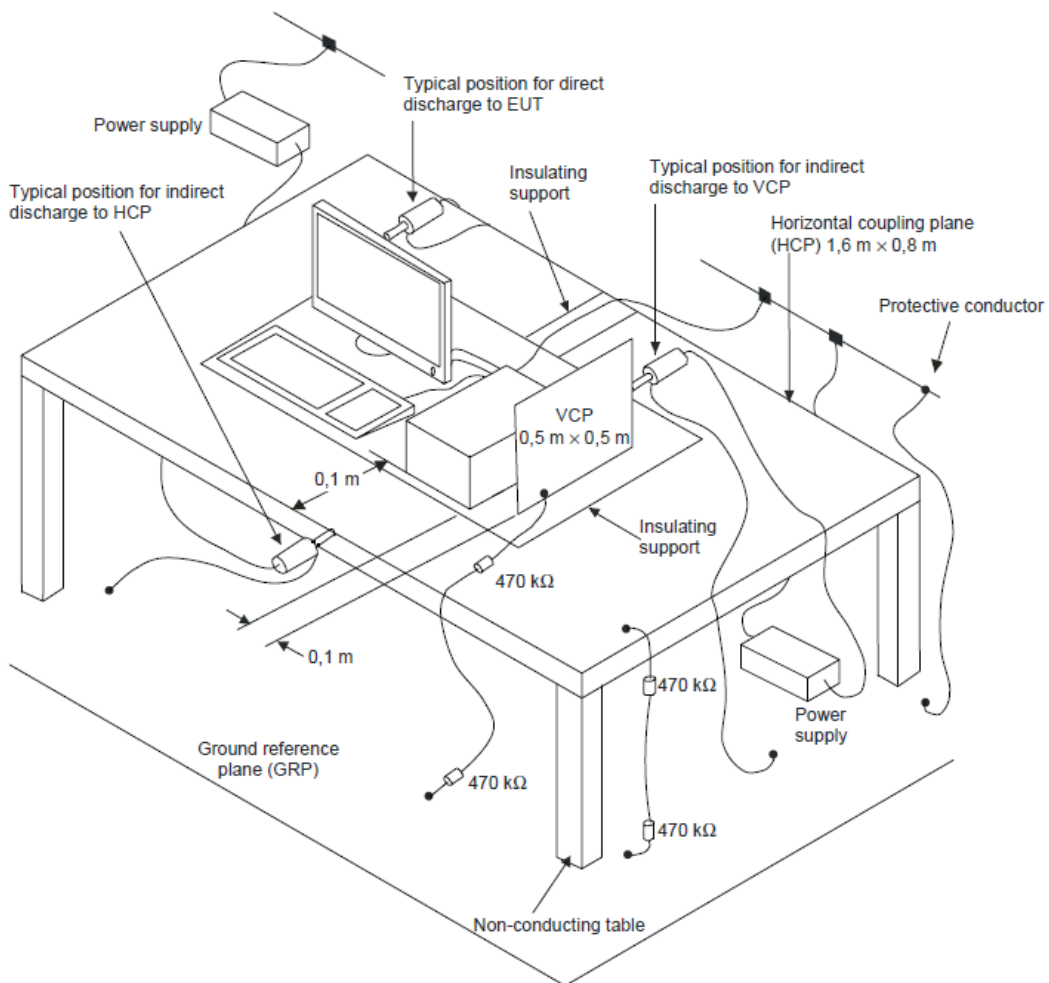

### < Floor-Standing equipment >

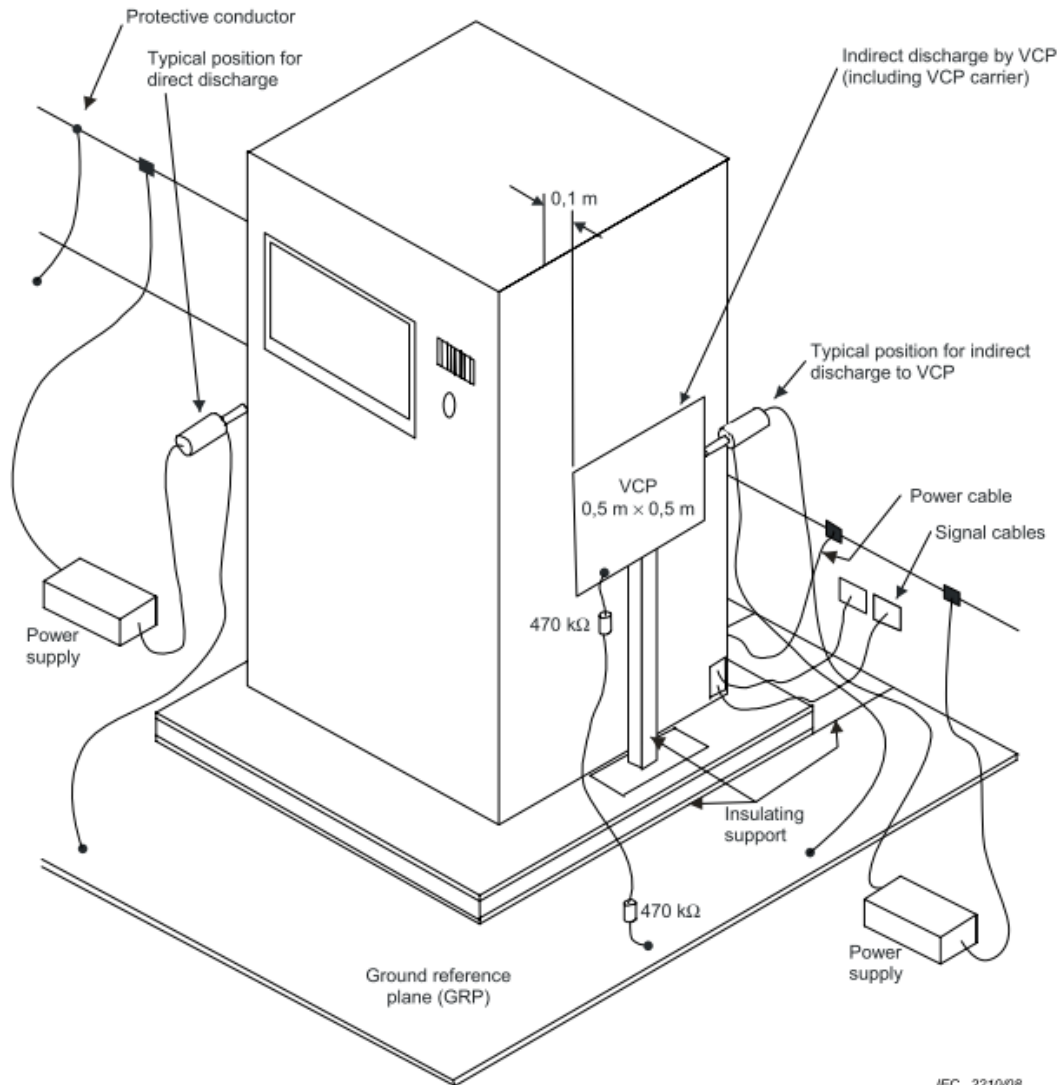

IEC 2210/08



### 5.3.6 Test Result

<b>Test Voltage</b>	230Vac, 50Hz	<b>Test Date</b>	2020/10/28
<b>Environmental Conditions</b>	23°C, 54% RH	<b>Pressure</b>	1008 mbar
<b>Tested by</b>	Guanwei Liao		

#### Test Results of Direct Application

Air Discharge				
Test Point	Discharge Level (kV)			Result
	±2	±4	±8	
Front	A	A	A	A
Back	A	A	A	A
Left	N/A	N/A	N/A	N/A
Right	N/A	N/A	N/A	N/A
Top	N/A	N/A	N/A	N/A
Bottom	N/A	N/A	N/A	N/A
Other	N/A	N/A	N/A	N/A

\* Test location(s) in which discharge to be applied illustrated by photos shown in next page(s).

Contact Discharge		
Test Point	Discharge Level (kV)	Result
	±4	
Front	N/A	N/A
Back	A	A
Left	A	A
Right	A	A
Top	A	A
Bottom	N/A	N/A
Other	N/A	N/A

\* Test location(s) in which discharge to be applied illustrated by photos shown in next page(s).

**Test Results of Indirect Application**

HCP Discharge		
Test Point	Discharge Level (kV)	Result
	±4	
Front	A	A
Back	A	A
Left	A	A
Right	A	A

VCP Discharge		
Test Point	Discharge Level (kV)	Result
	±4	
Front	A	A
Back	A	A
Left	A	A
Right	A	A

**Note:**

N/A: Not applicable

Criteria A: The EUT function was correct during the test.

Criteria A: (#1) No discharge point.

### Description of Test Points

Front



Back



\*Red Dot - Contact Discharged  
Blue Dot - Air Discharged

Left



Right



\*Red Dot - Contact Discharged  
Blue Dot - Air Discharged

Top



\*Red Dot - Contact Discharged  
Blue Dot - Air Discharged

### 5.3.7 Photographs of Test Configuration

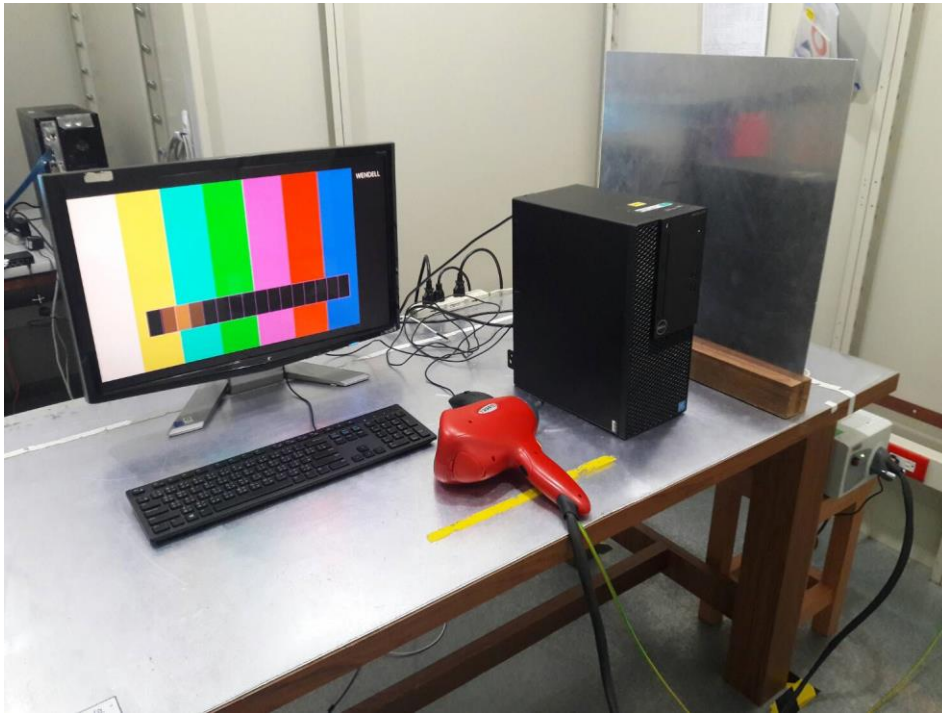

## 5.4 Radiated, Radio-frequency, Electromagnetic Field Immunity Test (RS)

### 5.4.1 Test Specification

<b>Standard</b>	IEC/EN 61000-4-3
<b>Frequency Range</b>	80MHz - 1000MHz 1800MHz, 2600MHz, 3500MHz, 5000MHz for spot test
<b>Field Strength</b>	3 V/m
<b>Modulation</b>	80%, AM Modulation 1 kHz Sine Wave
<b>Frequency Step</b>	1%
<b>Polarity of Antenna</b>	Horizontal and Vertical
<b>Test Distance</b>	3 m
<b>Antenna Height</b>	1.5 m
<b>Dwell Time</b>	3 seconds or not exceed 5 seconds

### 5.4.2 Test Instrument

Item	Equipment	Manufacturer	Model	Meter No.	Calibration Date
1	RadiCentre ® Modular EMC Test Systems	DARE	CTR1004B	CT-1-080	No calibration request
2	RF Signal Generator	DARE	RGN6000B	CT-1-080	Aug. 26, 2020
3	LINEAR POWER RF AMPLIFIER	OPHIR	5225	CT-1-082	No calibration request
4	LINEAR POWER RF AMPLIFIER	OPHIR	5193	CT-1-083	No calibration request
5	LINEAR POWER RF AMPLIFIER	OPHIR	5022A	CT-1-084	No calibration request
6	Periodic Test-Antenna	Schwarzbeck Mess - Elektronik	STLP 9128 E	CT-1-085	No calibration request
7	Stacked Microwave Log.-Per. Antenna	Schwarzbeck Mess - Elektronik	STLP 9149	CT-1-086	No calibration request
8	Electric Field Probe	FRANKONIA	EFS-10	CT-1-060a1	Aug. 27, 2020
9	Measurement Software	EMC-RS	Ver: 2.02	N/A	No calibration request

**Note:** 1. The calibration interval of the above test instruments is 12 months.

### 5.4.3 Test Procedure

The test procedure was in accordance with IEC 61000-4-3.

The table-top EUT and load, which are placed on a table that is 0.8 meter above ground, are placed with one coincident with the calibration plane such that the distance from antenna to the EUT was 3 meters.

Both horizontal and vertical polarization of the antenna and four sides of the EUT are set on measurement.

The EUT shall be positioned so that the four sides of the EUT shall be exposed to the electromagnetic field in sequence. In each position the performance of the EUT will be investigated.

In the case where the most sensitive surface side of the EUT is known throughout the frequency range (for example, via preliminary tests), testing may be restricted to that surface side only. Where it is not possible to determine the most sensitive face with any certainty (for example where different faces are sensitive at different frequencies) all four faces shall be tested.

If the EUT is too large such that it cannot be fully illuminated by the radiating antenna, or exceeds the size of the Uniform Field Area (UFA) then partial illumination shall be used. The EUT can be repositioned so that the front surface remains within the UFA in order to illuminate those sections of the EUT that were previously outside the UFA.

In order to judge the EUT performance, a CCD camera is used to monitor EUT screen.

All the scanning conditions are as follows:

	Condition of Test	Remarks
1	Field Strength	3V/m
2	Radiated Signal	AM 80% Modulated with 1kHz
3	Scanning Frequency	80M - 1000MHz
4	Spot Frequency for Wireless communication device	1800MHz, 2600MHz, 3500MHz, 5000MHz
5	Dwell Time	3.0 seconds or not exceed 5 seconds
6	Frequency Step Size $\Delta f$	1%

### 5.4.4 Deviation from Test Standard

No deviation

### 5.4.5 Test Setup

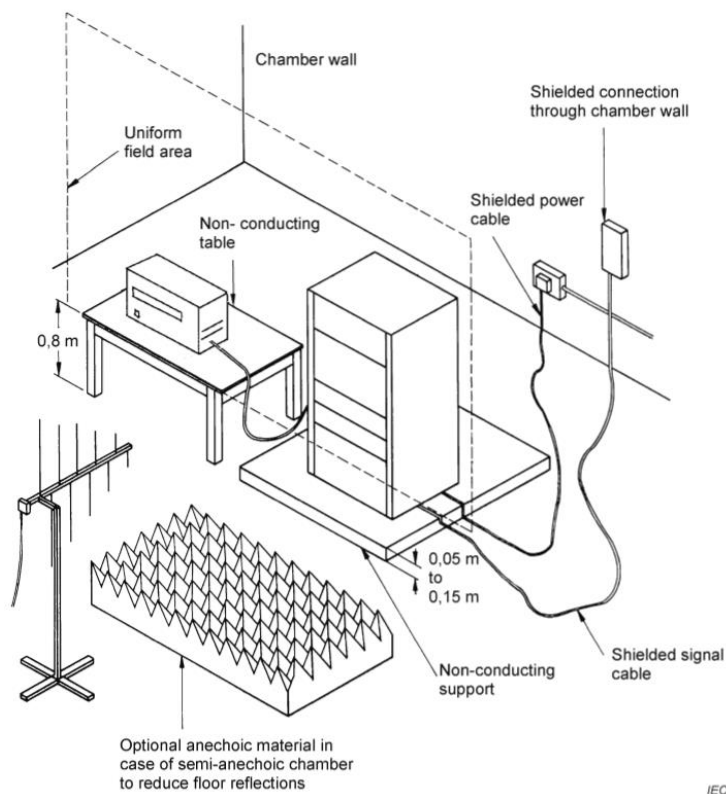
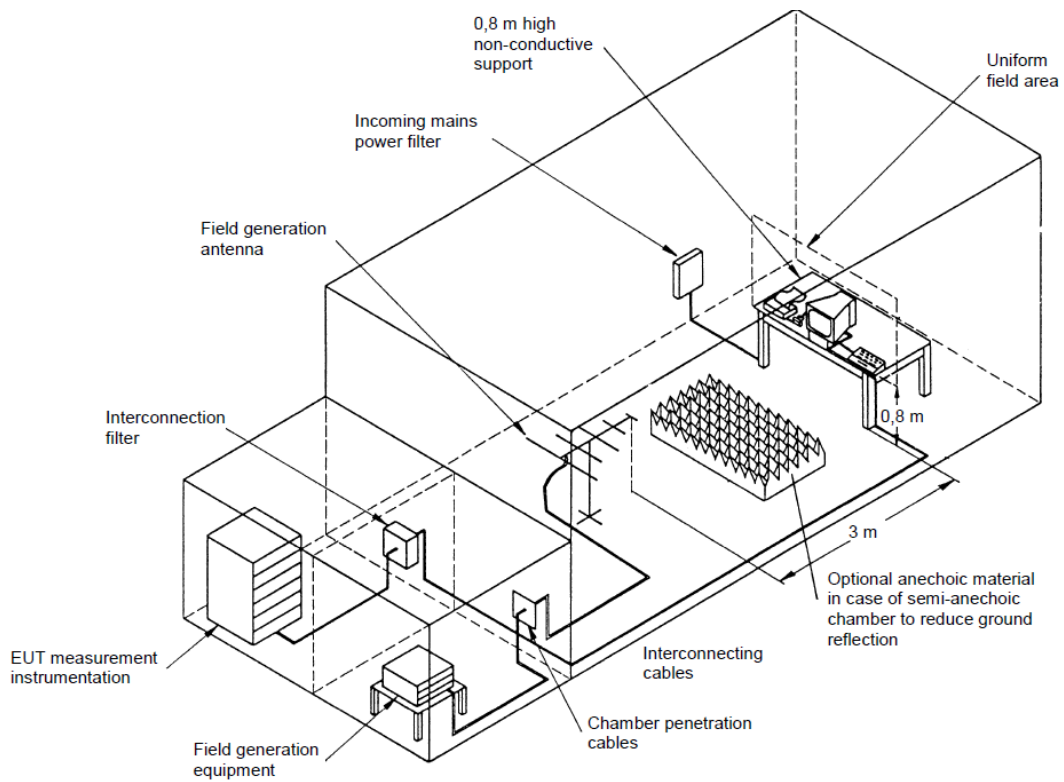

IEC 033/06



### 5.4.6 Test Result

<b>Test Voltage</b>	230Vac, 50Hz	<b>Environmental Conditions</b>	22°C, 53% RH
<b>Tested by</b>	Guanwei Liao	<b>Test Date</b>	2020/10/27

<b>Frequency Range (MHz)</b>	<b>Azimuth</b>	<b>Polarity</b>	<b>Field Strength (V/m)</b>	<b>Modulation</b>	<b>Result</b>
80-1000	0, 90, 180, 270	H/V	3	80% AM (1kHz)	A
1800	0, 90, 180, 270	H/V	3	80% AM (1kHz)	A
2600	0, 90, 180, 270	H/V	3	80% AM (1kHz)	A
3500	0, 90, 180, 270	H/V	3	80% AM (1kHz)	A
5000	0, 90, 180, 270	H/V	3	80% AM (1kHz)	A

**Note:**

Criteria A: The EUT function was correct during the test.

### 5.4.7 Photographs of Test Configuration

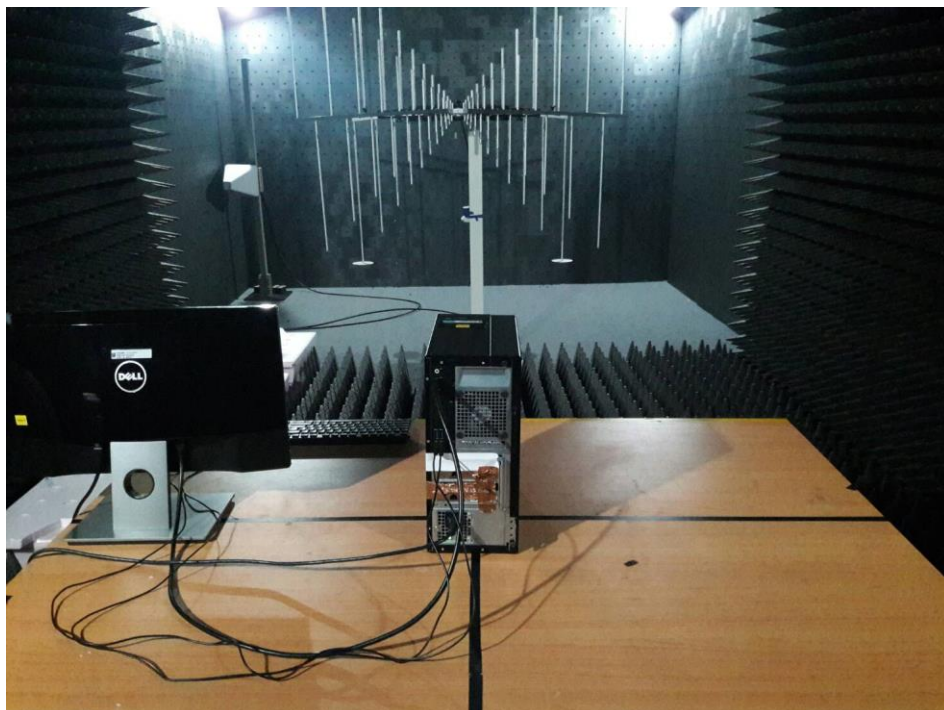
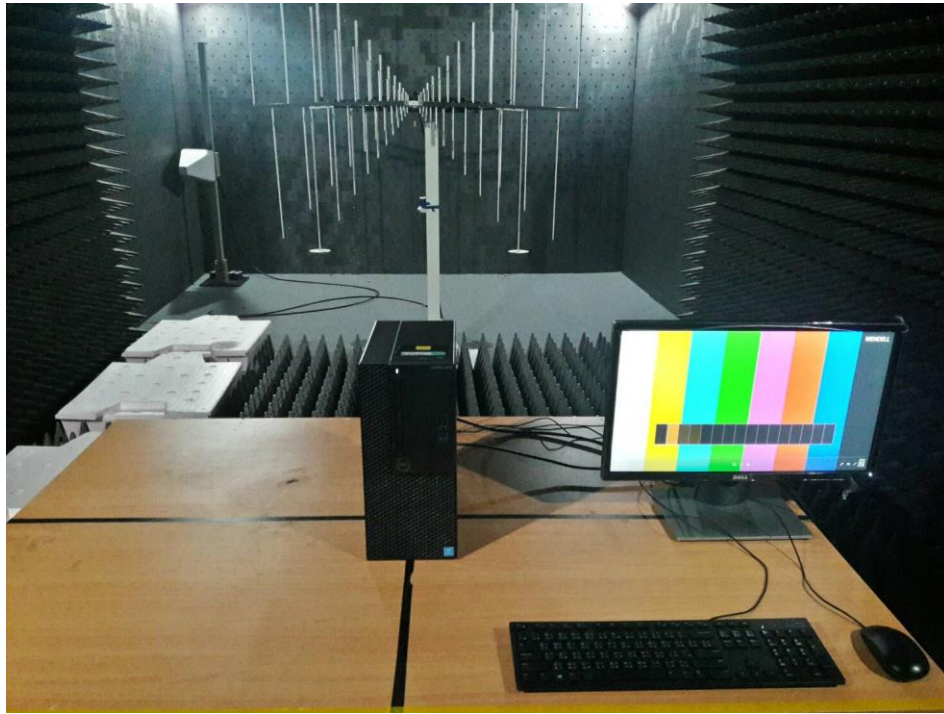



## **5.5 Electrical Fast Transient /Burst Immunity Test (EFT)**

The test is determined no necessary for the EUT do not operate from the AC main power lines or contain provisions for operation while connected to the AC main power lines.



## **5.6 Surge Immunity Test**

The test is determined no necessary for the EUT do not operate from the AC main power lines or contain provisions for operation while connected to the AC main power lines.



### **5.7 Continuous Conducted Disturbances (CS)**

The test is determined no necessary for the EUT do not operate from the AC main power lines or contain provisions for operation while connected to the AC main power lines.

## 5.8 Power Frequency Magnetic Field Immunity Test

### 5.8.1 Test Specification

<b>Standard</b>	IEC/EN 61000-4-8
<b>Frequency Range</b>	50/60Hz
<b>Field Strength</b>	1 A/m
<b>Observation Time</b>	1 minute
<b>Inductance Coil</b>	Rectangular type, 1mx1m

**Note:** 1. Applicable only to equipment containing devices intrinsically susceptible to magnetic field, such as CRT monitors, Hall effect elements, electron-dynamic microphones, magnetic field sensors or audio frequency transformers.

### 5.8.2 Test Instrument

<b>Item</b>	<b>Equipment</b>	<b>Manufacturer</b>	<b>Model</b>	<b>Meter No.</b>	<b>Calibration Date</b>
1	PFMF	HAEFELY	MFS-100	CT-1-066	Aug. 27, 2019

**Note:** 1. The calibration interval of the above test instruments is 24 months.

### 5.8.3 Test Procedure

The table-top EUT was placed on a table which is 0.8 meter above a metal ground plane measured at least 1m × 1m minimum. The test magnetic field shall be placed at central of the induction coil. The floor-standing EUT was placed on 0.1m insulation support unit between the EUT and ground reference plane.

The test magnetic Field shall be applied 10 minutes by the immersion method to the table-top EUT, and the induction coil shall be rotated by 90° in order to expose the EUT to the test field with different orientation (X, Y, Z Orientations). The test magnetic Field shall be applied 10 minutes by the proximity method to the floor-standing EUT, and the induction coil shall be rotated by 90° in order to expose the EUT to the test field with different orientation (X, Y, Z Orientations).

### 5.8.4 Deviation from Test Standard

No deviation

### 5.8.5 Test Setup

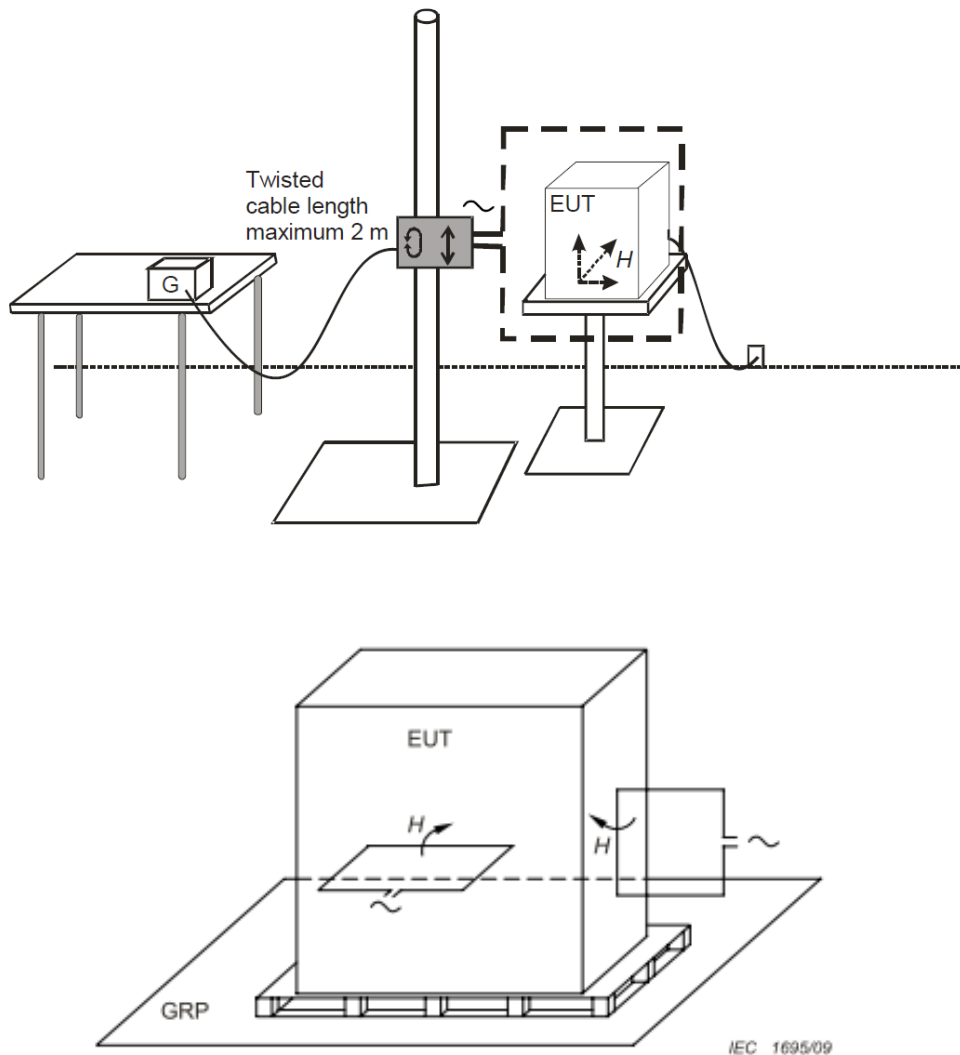

For the actual test configuration, please refer to 5.8.7.

**NOTE:**

**TABLETOP EQUIPMENT**

The equipment shall be subjected to the test magnetic field by using the induction coil of standard dimension (1 m x 1 m). The induction coil shall then be rotated by 90 degrees in order to expose the EUT to the test field with different orientations.

**FLOOR-STANDING EQUIPMENT**

The equipment shall be subjected to the test magnetic field by using induction coils of suitable dimensions. The test shall be repeated by moving and shifting the induction coils, in order to test the whole volume of the EUT for each orthogonal direction. The test shall be repeated with the coil shifted to different positions along the side of the EUT, in steps corresponding to 50 % of the shortest side of the coil. The induction coil shall then be rotated by 90 degrees in order to expose the EUT to the test field with different orientations.



### 5.8.6 Test Result

<b>Test Voltage</b>	230Vac, 50Hz	<b>Environmental Conditions</b>	24°C, 54% RH
<b>Tested by</b>	Guanwei Liao	<b>Test Date</b>	2020/10/26

<b>Test Coil Position</b>	<b>Frequency (Hz)</b>	<b>Magnetic Strength (A/m)</b>	<b>Result</b>
X - Axis	50/60	1	A
Y - Axis	50/60	1	A
Z - Axis	50/60	1	A

**Note:**

Criteria A: The EUT function was correct during the test.

### 5.8.7 Photographs of Test Configuration





## **5.9 Voltage Dips & Short Interruptions**

The test is determined no necessary for the EUT do not operate from the AC main power lines or contain provisions for operation while connected to the AC main power lines.

< End Page >