

# TEST REPORT

of

**EN 55032 / CISPR 32 / BS EN 55032  
AS/NZS CISPR 32 Class B  
EN 55035 / CISPR 35 / BS EN 55035 IMMUNITY  
EN IEC 61000-3-2 / BS EN IEC 61000-3-2  
EN 61000-3-3 / BS EN 61000-3-3**

Product: **ATA Dick Chip**  
Main Model: **ADC4**  
Brand: **Apacer**  
Applicant: **Apacer Technology Inc.**  
Address: **1F., No.32, Zhongcheng Rd., Tucheng Dist., New Taipei  
City 236, Taiwan , R.O.C.**

Test Performed by:



**International Standards Laboratory Corp. LT Lab.**

TEL: +886-3-263-8888 FAX: +886-3-263-8899

No. 120, Lane 180, Hsin Ho Rd., Lung-Tan Dist., Tao Yuan City 325, Taiwan

Report No.: **ISL-22LE0475CE35**  
Issue Date : **July 6, 2022**



Test results given in this report apply only to the specific sample(s) tested and are traceable to national or international standard through calibration of the equipment and evaluating measurement uncertainty herein. The uncertainty of the measurement does not include in consideration of the test result unless the customer required the determination of uncertainty via the agreement, regulation or standard document specification. This test report shall not be reproduced except in full, without the written approval of International Standards Laboratory Corp.

## Contents of Report

1.	General.....	1
1.1	Certification of Accuracy of Test Data .....	1
1.2	Test Standards .....	2
1.3	Description of EUT .....	4
1.4	Description of Support Equipment .....	5
1.5	Software for Controlling Support Unit.....	6
1.6	I/O Cable Condition of EUT and Support Units .....	7
2.	Power Main Port Conducted Emissions .....	8
2.1	Test Setup and Procedure .....	8
2.2	Conduction Test Data: Configuration 1 .....	10
2.3	Test Setup Photo.....	12
3.	Telecommunication Port Conducted Emissions .....	14
3.1	Test Setup and Procedure .....	14
4.	Radiated Disturbance Emissions .....	16
4.1	Test Setup and Procedure .....	16
4.2	Limit .....	18
4.3	Radiation Test Data: Configuration 1.....	20
4.4	Test Setup Photo.....	24
5.	Voltage Disturbance Emissions at Antenna Terminals .....	26
5.1	Test Setup and Procedure .....	26
6.	Differential Voltage Emissions.....	28
6.1	Test Setup and Procedure .....	28
7.	Outdoor units of home satellite receiving systems .....	30
7.1	Test Setup and Procedure .....	30
8.	Electrostatic discharge (ESD) immunity .....	32
8.1	Test Specification and Setup .....	32
8.2	Test Point.....	33
8.3	Test Setup Photo.....	34
9.	Radio-Frequency, Electromagnetic Field immunity.....	35
9.1	Test Specification and Setup .....	35
9.2	Test Setup Photo.....	36
10.	Power Frequency Magnetic Field immunity .....	37
10.1	Test Specification and Setup.....	37
10.2	Test Setup Photo .....	38
11.	Harmonics .....	39
11.1	Test Specification and Setup.....	39
12.	Voltage Fluctuations .....	41
12.1	Test Specification and Setup.....	41
12.2	Test Data: Configuration 1 .....	42
12.3	Test Setup Photo .....	43
13.	Appendix.....	44
13.1	Appendix A: Test Equipment.....	44
13.2	Appendix B: Uncertainty of Measurement .....	47
13.3	Appendix C: Photographs of EUT .....	48

# 1. General

## 1.1 Certification of Accuracy of Test Data

**Standards:** Please refer to 1.2

**Equipment Tested:** ATA Dick Chip

**Main Model:** ADC4

**Brand:** Apacer

**Applicant:** Apacer Technology Inc.

**Sample received Date:** June 23, 2022

**Final test Date:** EMI: refer to the date of test data  
EMS: July 1, 2022

**Test Site:** Chamber 12; Chamber 14; Conduction 03; Immunity 02

**Test Distance:** 10m; 3m (above 1GHz) (EMI test)

**Temperature:** refer to each site test data

**Humidity:** refer to each site test data

**Atmospheric Pressure:** 86 kPa to 106 kPa

**Input power:** Conduction input power: AC 230 V / 50 Hz  
Radiation input power: AC 230 V / 50 Hz  
Immunity input power: AC 230 V / 50 Hz

**Test Result:** **PASS**

**Report Engineer:** Helena Tsai

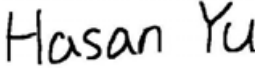
**Test Engineer:**  
  
\_\_\_\_\_  
Hasan Yu

**Approved By:**  
  
\_\_\_\_\_  
Benson Chen / Manager

## 1.2 Test Standards

The tests which this report describes were conducted by an independent electromagnetic compatibility consultant, International Standards Laboratory Corp. in accordance with the following

EN 55032:2015+A11:2020 and CISPR 32:2015+A1:2019 and BS EN 55032:2015+A11:2020 Class B Electromagnetic compatibility of multimedia equipment - Emission requirements.  
AS/NZS CISPR 32:2015+A1:2020 Class B Electromagnetic compatibility of multimedia equipment- Emission requirements

Performed Item	Test Performed	Deviation	Result
Conducted emissions from the AC mains power ports	Yes	No	PASS
Telecommunication Port Conducted Emissions (asymmetric mode)	N/A	N/A	N/A
Radiated emissions at frequencies below 1 GHz	Yes	No	PASS
Radiated emissions at frequencies above 1 GHz	Yes	No	PASS
Radiated emissions from FM receivers	N/A	N/A	N/A
Voltage Disturbance Emissions at Antenna Terminals	N/A	N/A	N/A
Differential voltage emissions	N/A	N/A	N/A
Outdoor units of home satellite receiving systems	N/A	N/A	N/A

EN 55035:2017+A11:2020 and CISPR 35:2016 modified and BS EN 55035: 2017+A11:2020 Electromagnetic compatibility of multimedia equipment - Immunity requirements.

Standard	Description	Results	Criteria
EN 61000-4-2:2009 IEC 61000-4-2:2008 BS EN 61000-4-2:2009	Electrostatic Discharge	Pass	B
EN 61000-4-3:2006+A1:2008 +A2:2010 IEC 61000-4-3:2006+A1:2007+A2:2010 BS EN 61000-4-3:2006+A2:2010	Radio-Frequency, Electromagnetic Field	Pass	A
EN 61000-4-8:2010 IEC 61000-4-8:2009 BS EN 61000-4-8:2010	Power Frequency Magnetic Field	Pass	A

Standard	Description	Results
EN IEC 61000-3-2:2019 IEC 61000-3-2:2018 BS EN IEC 61000-3-2:2019	Limits for harmonics current emissions	Pass
EN 61000-3-3:2013+A1:2019 IEC 61000-3-3:2013+A1:2017 BS EN 61000-3-3:2013+A1:2019	Limits for voltage fluctuations and flicker in low-voltage supply systems.	Pass

### 1.2.1 Performance Criteria for Compliance: EN 55035 and BS EN 55035

#### **Performance criterion A**

The equipment shall continue to operate as intended without operator intervention. No degradation of performance, loss of function or change of operating state is allowed below a performance level specified by the manufacturer when the equipment is used as intended. The performance level may be replaced by a permissible loss of performance. If the minimum performance level or the permissible performance loss is not specified by the manufacturer, then either of these may be derived from the product description and documentation, and by what the user may reasonably expect from the equipment if used as intended.

#### **Performance criterion B**

During the application of the disturbance, degradation of performance is allowed. However, no unintended change of actual operating state or stored data is allowed to persist after the test.

After the test, the equipment shall continue to operate as intended without operator intervention; no degradation of performance or loss of function is allowed, below a performance level specified by the manufacturer, when the equipment is used as intended. The performance level may be replaced by a permissible loss of performance.

If the minimum performance level (or the permissible performance loss), or recovery time, is not specified by the manufacturer, then either of these may be derived from the product description and documentation, and by what the user may reasonably expect from the equipment if used as intended.

#### **Performance criterion C**

Loss of function is allowed, provided the function is self-recoverable, or can be restored by the operation of the controls by the user in accordance with the manufacturer's instructions. A reboot or re-start operation is allowed.

Information stored in non-volatile memory, or protected by a battery backup, shall not be lost.

### 1.3 Description of EUT

## EUT

Product Name	ATA Dick Chip
Condition	Pre-Production
Model	ADC4
Brand Name	Apacer
Serial Number	N/A
Control IC	SMI 2236
PCB Number	48.26227.0010B
Memory Capacity	8GB
Power Supply	From Personal Computer Support
Maximum Operating Frequency	350MHz

The memory capacities listed below is chosen by the applicant to be the representative configuration for testing in this report.

#### EMI Test configurations:

Configuration	Test Model	Control IC	PCB Number	Memory Capacity
1	ADC4	SMI 2236	48.26227.0010B	8GB

#### EMI Noise Source

refer to the photo	Control IC
EUT-1	SMI 2236

#### EMI Solution

N/A

### 1.4 Description of Support Equipment

For EMI support unit 1~6

For EMS support unit 1~5, 7

No.	Unit	Model Serial No.	Brand	Power Cord	FCC ID
1	Personal Computer	B550 S/N: N/A	GIGABYTE	Non-shielded	FCC DOC
2	LCD Monitor	P2715Q S/N: N/A	DELL	Non-shielded	FCC DOC
3	USB Keyboard	SK-8175 S/N: N/A	DELL	N/A	FCC DOC
4	USB Mouse	MOCZUL S/N: N/A	DELL	N/A	FCC DOC
5	Printer	C930 S/N: N/A	HP	Non-shielded	FCC DOC
6	External HDD	SK2-U31AS-AKT S/N: N/A	AKiTiO	N/A	FCC DOC
7	Traveling USB 3.0 Disk	TS16GJF700 S/N: N/A	Transcend	N/A	FCC DOC

### 1.5 Software for Controlling Support Unit

Test programs exercising various part of EUT were used. The programs were executed as follows:

1. PC running Intel EMC.exe to read and write the EUT.
2. Send signal to the Printer through PC USB Port.
3. Read and write External HDD through PC USB Port(EMI).
4. Read and write Traveling USB 3.0 Disk through PC USB Port(EMS).
5. Send color bar to the LCD Monitor through PC HDMI Port.
6. Repeat the above steps.

	File	Version
EUT	Intel EMC	1.1
LCD Monitor	Windows Media Player	12.0
Printer	Intel EMC	1.1
External HDD	Intel EMC	1.1
Traveling USB 3.0 Disk	Intel EMC	1.1

### 1.6 I/O Cable Condition of EUT and Support Units

Description	Path	Length	Shielding	Core	Remark
AC Power Cord	100V (~240V) to PC SPS	1.8m	No	No	
LCD Monitor Data Cable	PC HDMI Port to LCD Monitor HDMI Port	2.0m	Yes	No	
Mouse Data Cable	Mouse to PC USB port	1.8m	Yes	No	
Keyboard Data Cable	Keyboard to PC USB port	1.8m	Yes	No	
USB Cable(EMI)	External HDD to PC USB Port	1.27m	Yes	No	
USB Cable(EMS)	Traveling USB 3.0 Disk to PC USB Port	1.0m	Yes	No	
Printer Data Cable	Printer to PC USB Port	1.8m	Yes	No	

## 2. Power Main Port Conducted Emissions

### 2.1 Test Setup and Procedure

#### 2.1.1 Test Setup

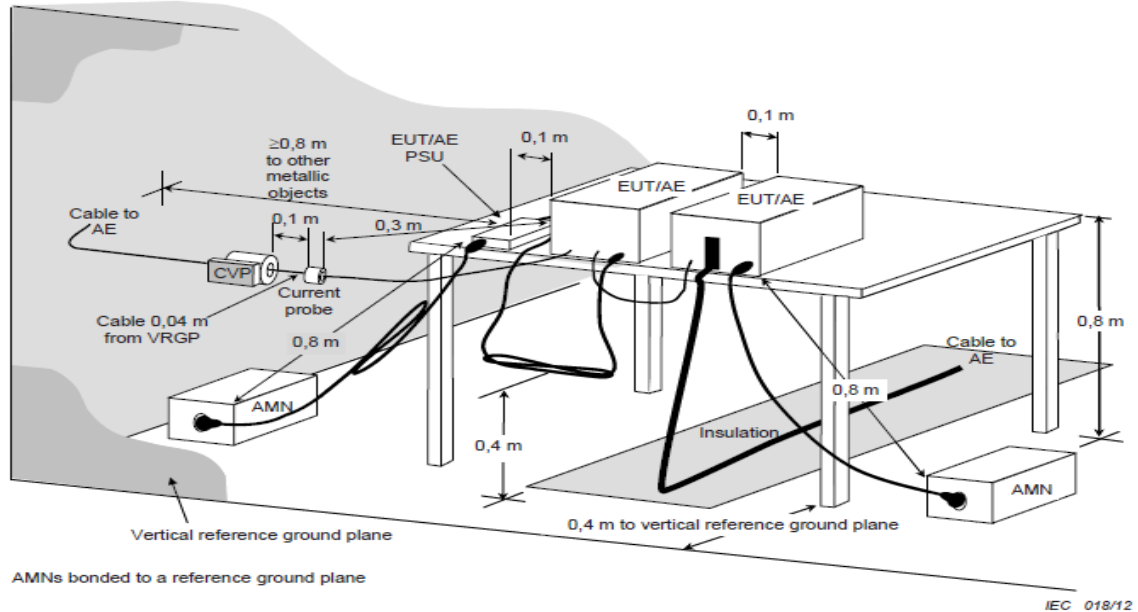

#### 2.1.2 Test Procedure

The measurements are performed in a shielded room test site. The EUT was placed on non-conduction 1.0m x 1.5m table, which is 0.8 meters above an earth-grounded.

Power to the EUT was provided through the AMN which has the Impedance (50ohm/50uH) vs. Frequency Characteristic in accordance with the standard. Power to the AMNs were filtered to eliminate ambient signal interference and these filters were bonded to the ground plane. Peripheral equipment required to provide a functional system (support equipment) for EUT testing was powered from the second AMN through a ganged, metal power outlet box which is bonded to the ground plane at the AMN.

The interconnecting cables were arranged and moved to get the maximum measurement. Both the line of power cord, live and neutral, were measured. All of the interface cables were manipulated according to EN 55032 / BS EN 55032 requirements.

The highest emissions were analyzed in details by operating the spectrum analyzer in fixed tuned mode to determine the nature of the emissions and to provide information which could be useful in reducing their amplitude.

#### 2.1.3 EMI Receiver/Spectrum Analyzer Configuration (for the frequencies tested)

Frequency Range:	150kHz--30MHz
Detector Function:	Quasi-Peak / Average Mode
Resolution Bandwidth:	9kHz

**2.1.4 Limit**

**Conducted emissions from the AC mains power ports of Class A equipment:**

Frequency	QP	AV
MHz	dB( $\mu$ V)	dB( $\mu$ V)
0.15-0.50	79	66
0.50-30	73	60
Note: The lower limit shall apply at the transition frequencies		

**Conducted emissions from the AC mains power ports of Class B equipment:**

Frequency	QP	AV
MHz	dB( $\mu$ V)	dB( $\mu$ V)
0.15-0.50	66-56	56-46
0.50-5.0	56	46
5.0-30	60	50
Note: The lower limit shall apply at the transition frequencies		

## 2.2 Conduction Test Data: Configuration 1

-Live

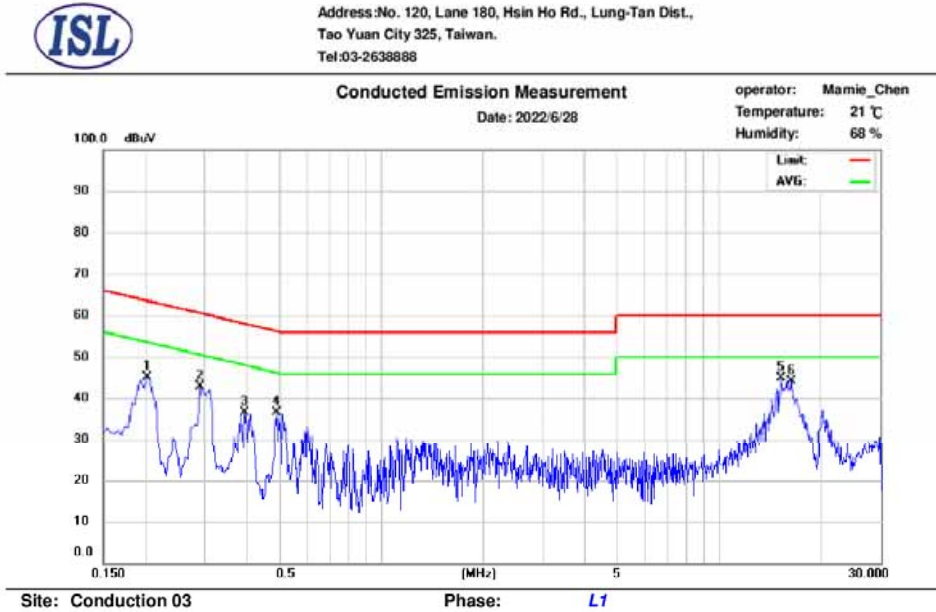

No.	Frequency (MHz)	QP_R (dBuV)	AVG_R (dBuV)	Correct Factor (dB)	QP Emission (dBuV)	QP Limit (dBuV)	QP Margin (dB)	AVG Emission (dBuV)	AVG Limit (dBuV)	AVG Margin (dB)
1	0.202	35.33	20.97	9.65	44.98	63.53	-18.55	30.62	53.53	-22.91
2	0.290	30.12	15.37	9.65	39.77	60.52	-20.75	25.02	50.52	-25.50
3	0.394	24.64	9.13	9.66	34.30	57.98	-23.68	18.79	47.98	-29.19
4	0.490	24.21	8.27	9.65	33.86	56.17	-22.31	17.92	46.17	-28.25
5	15.342	31.10	28.45	9.93	41.03	60.00	-18.97	38.38	50.00	-11.62
6	16.446	28.02	24.47	9.94	37.96	60.00	-22.04	34.41	50.00	-15.59

Note:

Margin = QP/AVG Emission - Limit

QP/AVG Emission = QP\_R/AVG\_R + Correct Factor

Correct Factor = LISN Loss + Cable Loss

A margin of -8dB means that the emission is 8dB below the limit

The frequency spectrum graph is for final peak graph, and the attached table is for QP/AVG test result.

If peak data can pass, it will be shown in "QP/AVG Correct" column, if not, QP/AVG data will instead.

- Neutral

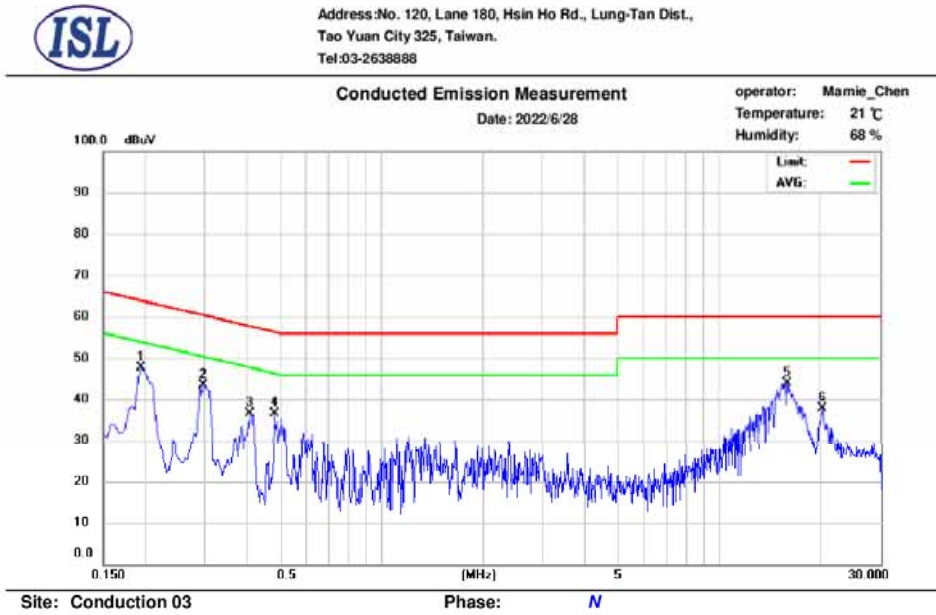

No.	Frequency (MHz)	QP_R (dBuV)	AVG_R (dBuV)	Correct Factor (dB)	QP Emission (dBuV)	QP Limit (dBuV)	QP Margin (dB)	AVG Emission (dBuV)	AVG Limit (dBuV)	AVG Margin (dB)
1	0.194	36.46	20.88	9.67	46.13	63.86	-17.73	30.55	53.86	-23.31
2	0.298	30.61	19.60	9.67	40.28	60.30	-20.02	29.27	50.30	-21.03
3	0.410	23.15	7.25	9.68	32.83	57.65	-24.82	16.93	47.65	-30.72
4	0.482	22.91	8.28	9.67	32.58	56.30	-23.72	17.95	46.30	-28.35
5	15.890	32.34	30.69	10.04	42.38	60.00	-17.62	40.73	50.00	-9.27
6	20.298	25.32	22.70	10.09	35.41	60.00	-24.59	32.79	50.00	-17.21

Note:

Margin = QP/AVG Emission - Limit

QP/AVG Emission = QP\_R/AVG\_R + Correct Factor

Correct Factor = LISN Loss + Cable Loss

A margin of -8dB means that the emission is 8dB below the limit

The frequency spectrum graph is for final peak graph, and the attached table is for QP/AVG test result.

If peak data can pass, it will be shown in "QP/AVG Correct" column, if not, QP/AVG data will instead.

### 2.3 Test Setup Photo

Front View



Back View





**3.1.4 Limit**

**Asymmetric mode conducted emissions from Class\_A equipment:**

**Applicable to**

- 1. wired network ports.**
- 2. optical fibre ports with metallic shield or tension members.**
- 3. antenna ports.**

Frequency range MHz	Coupling device	Detector type / bandwidth	Class_A voltage limits dB( $\mu$ V)	Class_A current limits dB( $\mu$ A)
0.15-0.5	AAN	Quasi Peak / 9 kHz	97-87	n/a
0.5-30			87	
0.15-0.5	AAN	Average / 9 kHz	84-74	
0.5-30			74	
0.15-0.5	CVP and current probe	Quasi Peak / 9 kHz	97-87	53-43
0.5-30			87	43
0.15-0.5	CVP and current probe	Average / 9 kHz	84-74	40-30
0.5-30			74	30
0.15-0.5	Current Probe	Quasi Peak / 9 kHz	n/a	53-43
0.5-30				43
0.15-0.5	Current Probe	Average / 9 kHz		40-30
0.5-30				30

**Asymmetric mode conducted emissions from Class\_B equipment:**

**Applicable to:**

1. wired network ports.
2. optical fibre ports with metallic shield or tension members.
3. broadcast receiver tuner ports.
4. antenna ports.

Frequency range MHz	Coupling device	Detector type / bandwidth	Class_B voltage limits dB( $\mu$ V)	Class_B current limits dB( $\mu$ A)
0.15-0.5	AAN	Quasi Peak / 9 kHz	84-74	n/a
0.5-30			74	
0.15-0.5	AAN	Average / 9 kHz	74-64	
0.5-30			64	
0.15-0.5	CVP and current probe	Quasi Peak / 9 kHz	84-74	40-30
0.5-30			74	30
0.15-0.5	CVP and current probe	Average / 9 kHz	74-64	30-20
0.5-30			64	20
0.15-0.5	Current Probe	Quasi Peak / 9 kHz	n/a	40-30
0.5-30				30
0.15-0.5	Current Probe	Average / 9 kHz		30-20
0.5-30				20

**\*\*Remarks: It is not necessary to be tested on this item.**

## 4. Radiated Disturbance Emissions

### 4.1 Test Setup and Procedure

#### 4.1.1 Test Setup

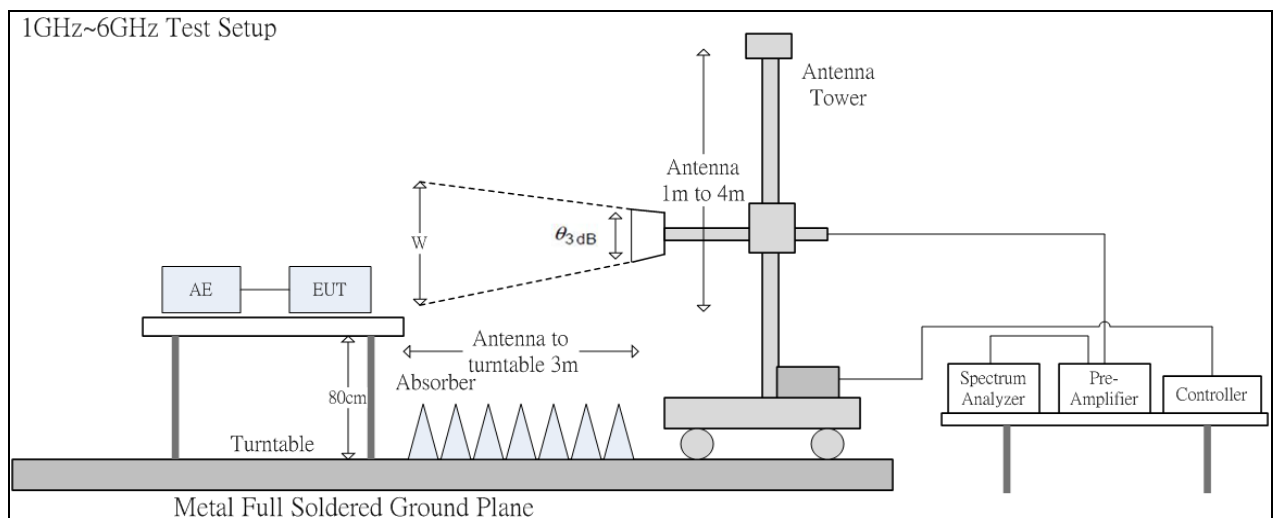
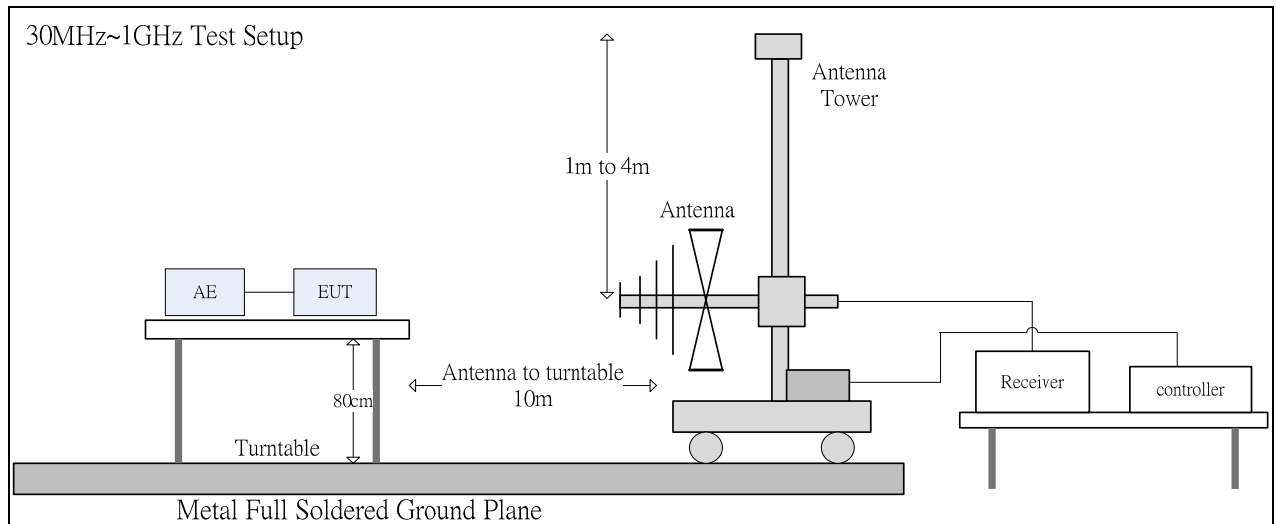
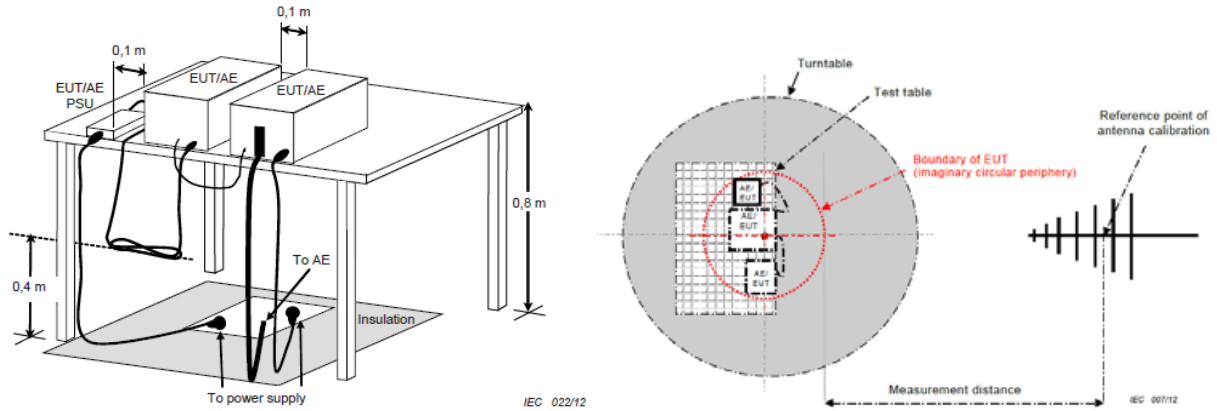

The 3dB beam width of the horn antenna used for the test is as shown in the table below.

Frequency (GHz)	E-plane	H-plane	$\theta_{3dB}(\text{min})$	d= 3 m
				w (m)
1	88°	147°	88°	5.79
2	68°	119°	68°	4.04
3	73°	92°	73°	4.44
4	70°	89°	70°	4.20
5	55°	60°	55°	3.12
6	63°	62°	62°	3.60

#### 4.1.2 Test Procedure

The radiated emissions test will then be repeated on the chamber to measure the amplitudes accurately and without the multiple reflections existing in the shielded room. The EUT and support equipment are set up on the turntable of one of 10 meter chamber. Desktop EUT are set up on a FRP stand 0.8 meter above the ground or floor-standing arrangement shall be placed on the horizontal ground reference plane.

For the initial measurements, the receiving antenna is varied from 1-4 meter height and is changed in the vertical plane from vertical to horizontal polarization at each frequency. The highest emissions between 30 MHz to 1000 MHz were analyzed in details by operating the spectrum analyzer and/or EMI receiver in quasi-peak mode to determine the precise amplitude of the emissions. The highest emissions between 1 GHz to 6 GHz were analyzed in details by operating the spectrum analyzer in peak and average mode to determine the precise amplitude of the emissions. The test volume for a height of up to 30 cm may be obstructed by absorber placed on the ground plane.

At the highest amplitudes observed, the EUT is rotated in the horizontal plane while changing the antenna polarization in the vertical plane to maximize the reading. The interconnecting cables were arranged and moved to get the maximum measurement. Once the maximum reading is obtained, the antenna elevation and polarization will be varied between specified limits to maximize the readings. All of the interface cables were manipulated according to EN 55032 / BS EN 55032 requirements.

The highest internal source of an EUT is defined as the highest frequency generated or used within the EUT or on which the EUT operates or tunes.

If the highest frequency of the internal sources of the EUT is less than 108 MHz, the measurement shall only be made up to 1 GHz.

If the highest frequency of the internal sources of the EUT is between 108 MHz and 500 MHz, the measurement shall only be made up to 2 GHz.

If the highest frequency of the internal sources of the EUT is between 500 MHz and 1 GHz, the measurement shall only be made up to 5 GHz.

If the highest frequency of the internal sources of the EUT is above 1 GHz, the measurement shall be made up to 5 times the highest frequency or 6 GHz, whichever is less.

**4.1.3 Spectrum Analyzer Configuration (for the frequencies tested)**

Frequency Range: 30MHz--1000MHz  
 Detector Function: Quasi-Peak Mode  
 Resolution Bandwidth: 120kHz

Frequency Range: Above 1 GHz to 6 GHz  
 Detector Function: Peak/Average Mode  
 Resolution Bandwidth: 1MHz

**4.2 Limit**

**Radiated emissions at frequencies up to 1 GHz for Class\_A equipment:**

Frequency range MHz	Measurement		Class_A limits dB(μV/m)
	Distance m	Detector type / bandwidth	OATS/SAC
30-230	10	Quasi Peak / 120 kHz	40
230-1000			47
30-230	3		50
230-1000			57

**Radiated emissions at frequencies above 1 GHz for Class\_A equipment:**

Frequency range MHz	Measurement		Class_A limits dB(μV/m)
	Distance m	Detector type / bandwidth	FSOATS
1000-3000	3	Average / 1MHz	56
3000-6000			60
1000-3000		Peak / 1MHz	76
3000-6000			80

**Radiated emissions at frequencies up to 1 GHz for Class\_B equipment:**

Frequency range MHz	Measurement		Class_B limits dB(μV/m)
	Distance m	Detector type / bandwidth	OATS/SAC
30-230	10	Quasi Peak / 120 kHz	30
230-1000			37
30-230	3		40
230-1000			47

**Radiated emissions at frequencies above 1 GHz for Class B equipment:**

Frequency range MHz	Measurement		Class_B limits dB( $\mu$ V/m)
	Distance m	Detector type / bandwidth	FSOATS
1000-3000	3	Average / 1MHz	50
3000-6000			54
1000-3000		Peak / 1MHz	70
3000-6000			74

**Radiated emissions from FM receivers:**

Frequency range MHz	Measurement		Class_B limits dB( $\mu$ V/m)		
	Distance m	Detector type / bandwidth	Fundamental	Harmonics	
			OATS/SAC	OATS/SAC	
30-230	10	Quasi Peak / 120 kHz	50	42	
230-300				42	
300-1000				46	
30-230	3		Quasi Peak / 120 kHz	60	52
230-300					52
300-1000					56

### 4.3 Radiation Test Data: Configuration 1 - Radiated Emissions (Horizontal)

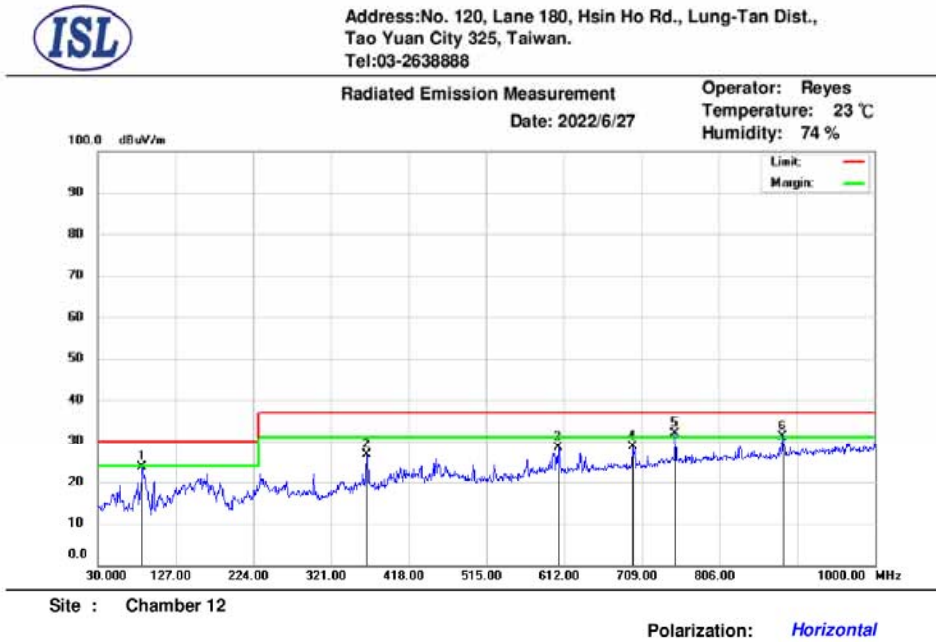

Mk.	Frequency (MHz)	RX_R (dBuV)	Correct Factor (dB/m)	Emission (dBuV/m)	Limit (dBuV/m)	Margin (dB)	Ant.Pos (cm)	Tab.Pos (deg.)	Detector
1	85.29	45.48	-21.94	23.54	30.00	-6.46	400	30	peak
2	365.62	39.58	-12.92	26.66	37.00	-10.34	200	8	peak
3	605.21	35.44	-7.08	28.36	37.00	-8.64	100	117	peak
4	697.36	34.66	-6.04	28.62	37.00	-8.38	400	304	peak
5	750.71	36.52	-4.72	31.80	37.00	-5.20	100	316	peak
6	885.54	34.68	-3.50	31.18	37.00	-5.82	200	0	peak

\* Note:

Margin = Emission – Limit

Emission = Radiated Amplitude + Correct Factor

Correct Factor = Antenna Correction Factor + Cable Loss – Pre-Amplifier Gain

A margin of -8dB means that the emission is 8dB below the limit

Antenna Distance: 10 meters

Below 1GHz test, if the peak measured value meets the QP limit, it is unnecessary to perform the QP measurement.



Address: No. 120, Lane 180, Hsin Ho Rd., Lung-Tan Dist.,  
Tao Yuan City 325, Taiwan.  
Tel: 03-2638888

Radiated Emission Measurement  
Date: 2022/6/28

Operator: Jeff Chou  
Temperature: 23 °C  
Humidity: 59 %

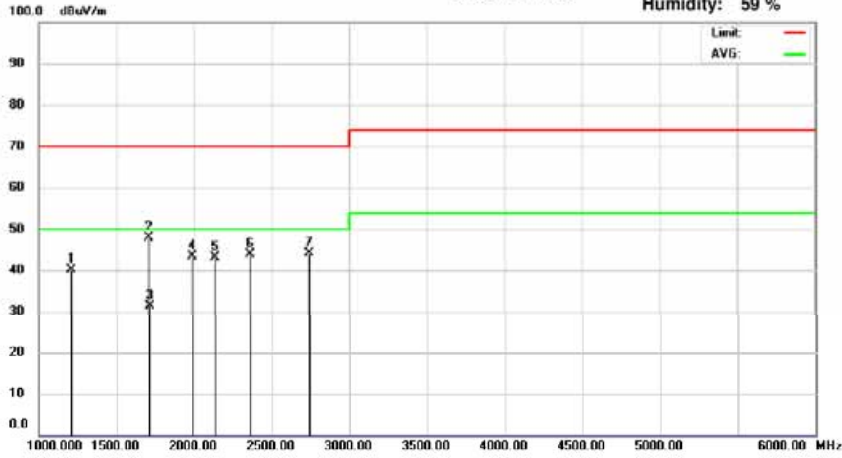

Site : Chamber 14

Polarization: *Horizontal*

Mk.	Frequency (MHz)	RX_R (dBuV)	Correct Factor(dB/m)	Emission (dBuV/m)	Limit (dBuV/m)	Margin (dB)	Ant.Pos (cm)	Tab.Pos (deg.)	Detector
1	1210.00	55.40	-15.25	40.15	70.00	-29.85	299	57	peak
2	1710.00	62.53	-14.59	47.94	70.00	-22.06	299	62	peak
3	1713.00	45.87	-14.58	31.29	50.00	-18.71	298	188	AVG
4	1990.00	55.63	-12.27	43.36	70.00	-26.64	304	193	peak
5	2135.00	55.23	-12.17	43.06	70.00	-26.94	299	321	peak
6	2365.00	55.54	-11.56	43.98	70.00	-26.02	100	223	peak
7	2740.00	54.99	-10.97	44.02	70.00	-25.98	299	98	peak

\* Note:

Margin = Emission – Limit

Emission = Radiated Amplitude + Correct Factor

Correct Factor = Antenna Correction Factor + Cable Loss – Pre-Amplifier Gain

A margin of -8dB means that the emission is 8dB below the limit

Antenna Distance: 3 meters

Above 1GHz test, if the peak measured value meets the average limit, it is unnecessary to perform the average measurement.

**-Radiated Emissions (Vertical)**

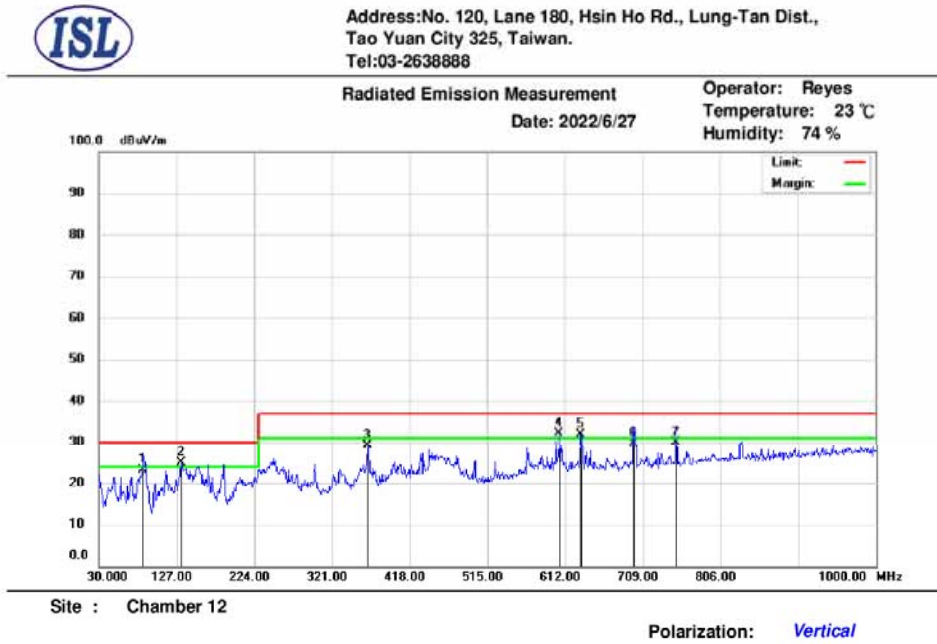

Mk.	Frequency (MHz)	RX_R (dBuV)	Correct Factor (dB/m)	Emission (dBuV/m)	Limit (dBuV/m)	Margin (dB)	Ant.Pos (cm)	Tab.Pos (deg.)	Detector
1	85.29	44.95	-21.94	23.01	30.00	-6.99	200	273	QP
2	132.82	42.13	-17.17	24.96	30.00	-5.04	100	155	peak
3	365.62	41.93	-12.92	29.01	37.00	-7.99	100	149	peak
4	605.21	39.19	-7.08	32.11	37.00	-4.89	200	14	peak
5	631.40	38.85	-6.89	31.96	37.00	-5.04	200	77	peak
6	697.36	35.70	-6.04	29.66	37.00	-7.34	200	88	QP
7	750.71	34.68	-4.72	29.96	37.00	-7.04	200	357	QP

\* Note:

Margin = Emission – Limit

Emission = Radiated Amplitude + Correct Factor

Correct Factor = Antenna Correction Factor + Cable Loss – Pre-Amplifier Gain

A margin of -8dB means that the emission is 8dB below the limit

Antenna Distance: 10 meters

Below 1GHz test, if the peak measured value meets the QP limit, it is unnecessary to perform the QP measurement.



Address: No. 120, Lane 180, Hsin Ho Rd., Lung-Tan Dist.,  
Tao Yuan City 325, Taiwan.  
Tel: 03-2638888

Radiated Emission Measurement  
Date: 2022/6/28

Operator: Jeff Chou  
Temperature: 23 °C  
Humidity: 59 %

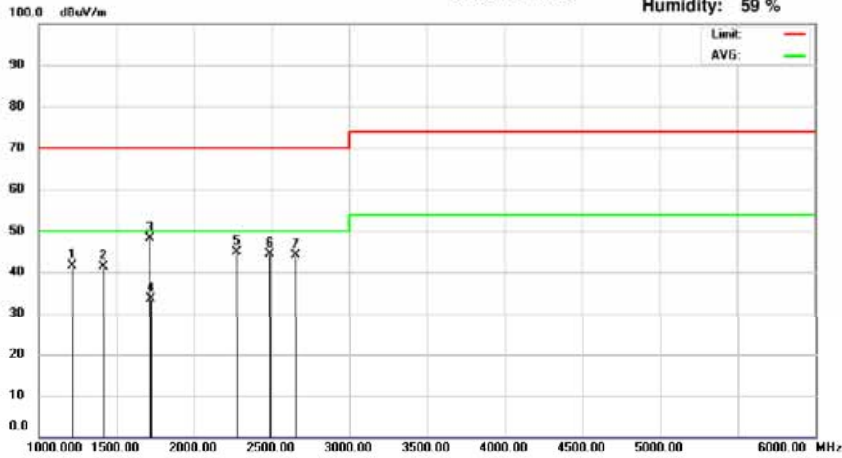

Site : Chamber 14

Polarization: Vertical

Mk.	Frequency (MHz)	RX_R (dBuV)	Correct Factor(dB/m)	Emission (dBuV/m)	Limit (dBuV/m)	Margin (dB)	Ant.Pos (cm)	Tab.Pos (deg.)	Detector
1	1215.00	56.95	-15.27	41.68	70.00	-28.32	100	134	peak
2	1415.00	57.23	-15.93	41.30	70.00	-28.70	100	150	peak
3	1715.00	62.78	-14.58	48.20	70.00	-21.80	100	213	peak
4	1721.49	48.22	-14.57	33.65	50.00	-16.35	100	221	AVG
5	2275.00	56.71	-11.90	44.81	70.00	-25.19	100	77	peak
6	2490.00	55.77	-11.44	44.33	70.00	-25.67	150	197	peak
7	2655.00	55.07	-11.05	44.02	70.00	-25.98	240	0	peak

\* Note:

Margin = Emission – Limit

Emission = Radiated Amplitude + Correct Factor

Correct Factor = Antenna Correction Factor + Cable Loss – Pre-Amplifier Gain

A margin of -8dB means that the emission is 8dB below the limit

Antenna Distance: 3 meters

Above 1GHz test, if the peak measured value meets the average limit, it is unnecessary to perform the average measurement.

#### 4.4 Test Setup Photo

Front View (30MHz~1GHz)

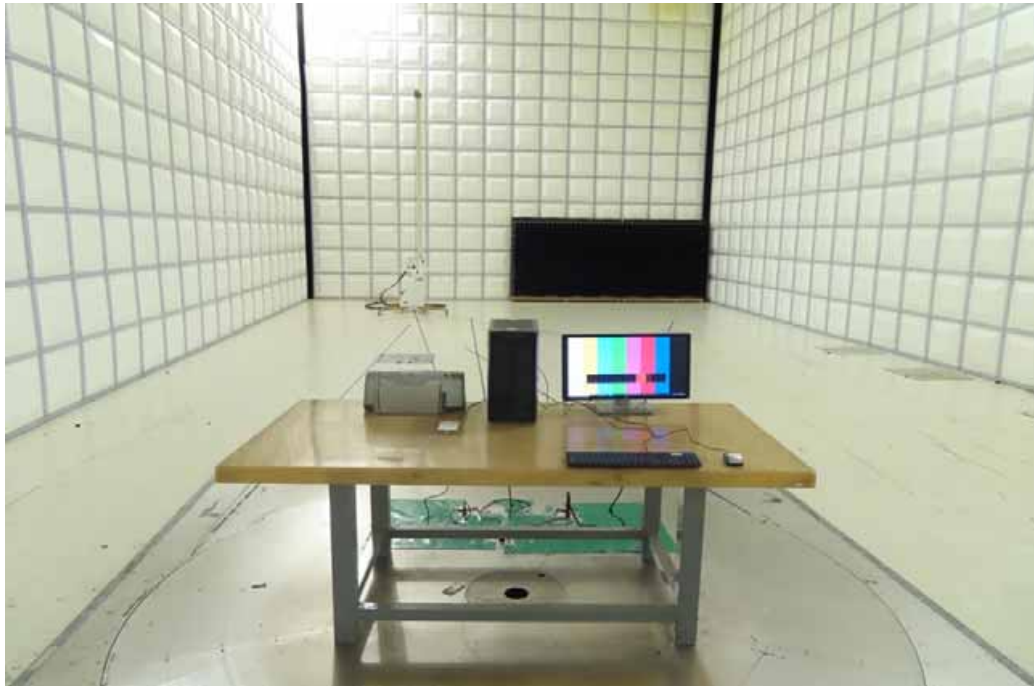

Back View (30MHz~1GHz)

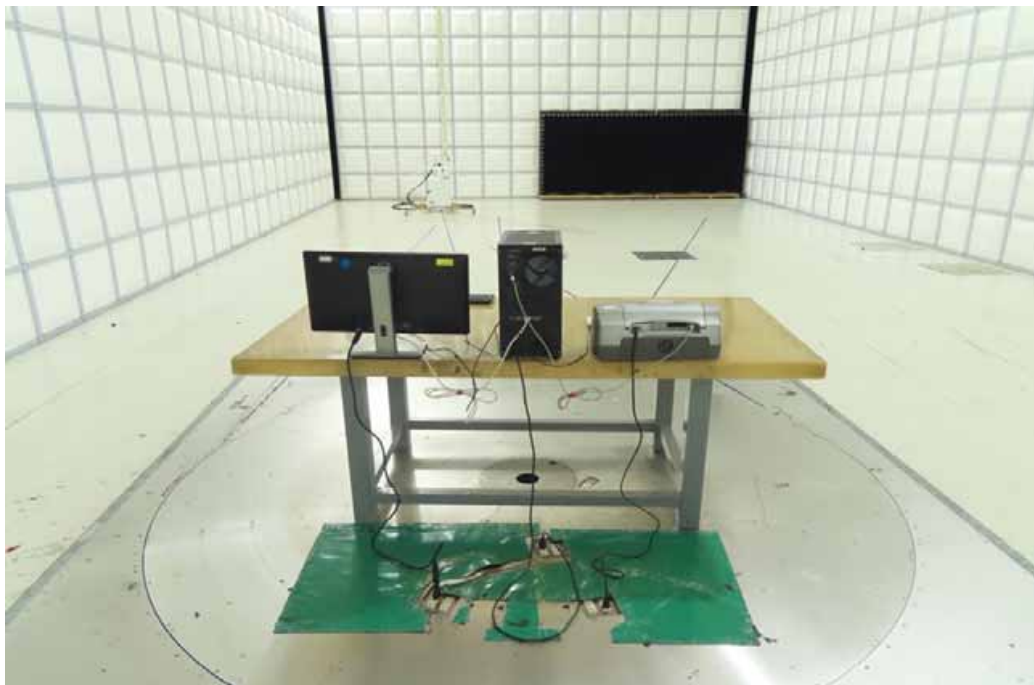

Front View (above 1GHz)



Back View (above 1GHz)

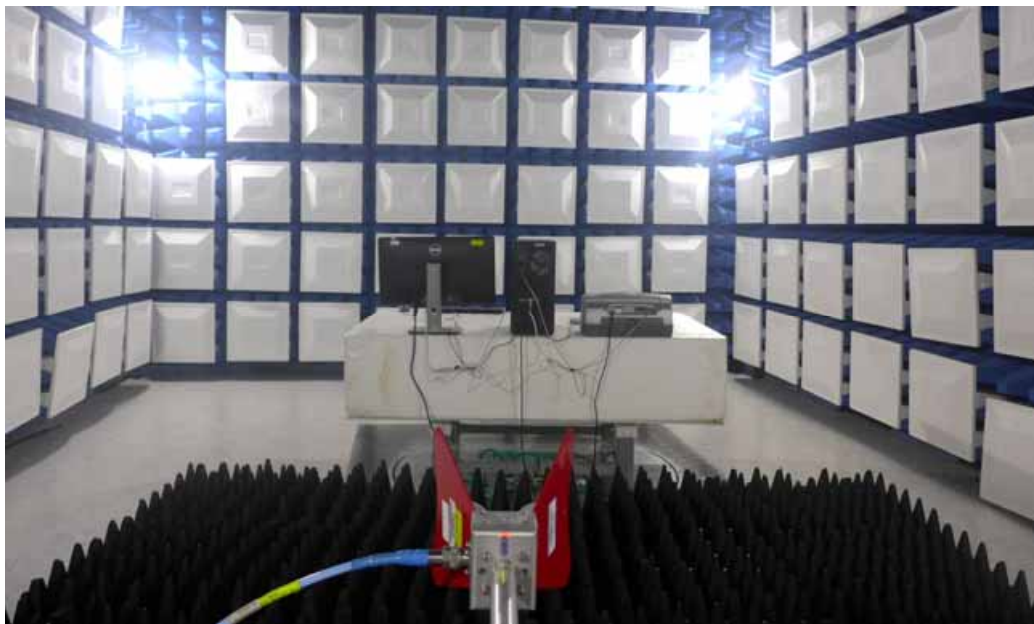

## 5. Voltage Disturbance Emissions at Antenna Terminals

### 5.1 Test Setup and Procedure

#### 5.1.1 Test Setup

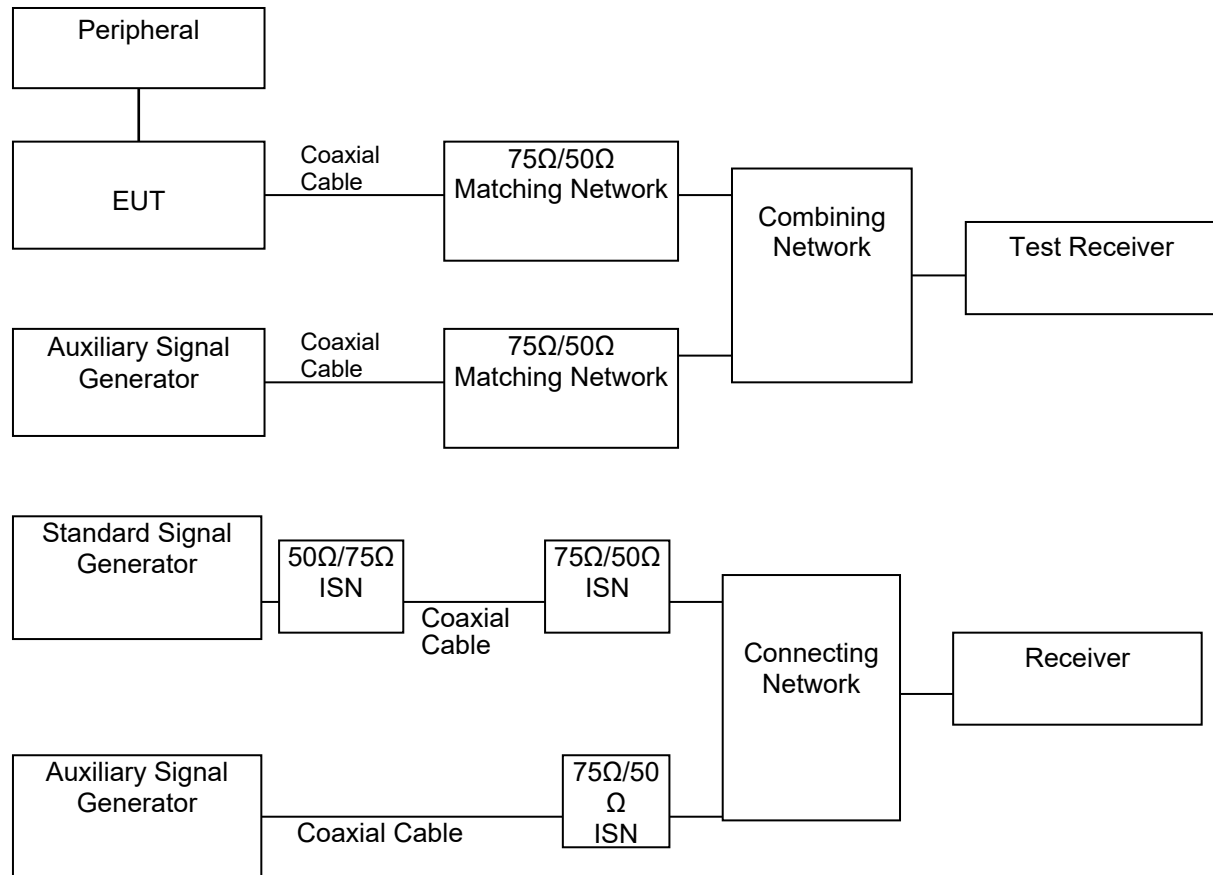

#### 5.1.2 Test Procedure

The output level of the auxiliary signal generator was set to 70dBuV at the EUT antenna terminal with 75 ohms impedance with an un-modulated carrier.

The highest emissions were analyzed in details by operating the spectrum analyzer and/or EMI receiver in quasi-peak mode to determine the precise amplitude of the emissions. The power of EUT was switched off to make sure the emission was not contributed by the auxiliary signal generator. While doing so, the interconnecting cables and major parts of the system were moved around to maximize the emission.

#### 5.1.3 EMI Receiver Configuration (for the frequencies tested)

Frequency Range:	30MHz-2150MHz
Detector Function:	Quasi-Peak Mode
Resolution Bandwidth:	120kHz

**5.1.4 Limit**

**Applicable to:**

- 1. TV broadcast receiver tuner ports with an accessible connector.**
- 2. RF modulator output ports.**
- 3. FM broadcast receiver tuner ports with an accessible connector.**

Table clause	Frequency range MHz	Detector type/ bandwidth	Class B limits dB(μV) 75 Ω			Applicability
			Other	Local Oscillator Fundamental	Local Oscillator Harmonics	
A12.1	30 – 950	For frequencies ≤1 GHz  Quasi Peak/ 120 kHz	46	46	46	See a)
	950 – 2 150		46	54	54	
A12.2	950 – 2 150		46	54	54	See b)
A12.3	30 – 300		46	54	50	See c)
	300 – 1 000	52				
A12.4	30 – 300	For frequencies ≥1 GHz	46	66	59	See d)
	300 – 1 000				52	
A12.5	30 – 950	Peak/ 1 MHz	46	76	46	See e)
	950 – 2 150			n/a	54	

a) Television receivers (analogue or digital), video recorders and PC TV broadcast receiver tuner cards working in channels between 30 MHz and 1 GHz, and digital audio receivers.

b) Tuner units (not the LNB) for satellite signal reception.

c) Frequency modulation audio receivers and PC tuner cards.

d) Frequency modulation car radios.

e) Applicable to EUTs with RF modulator output ports (for example DVD equipment, video recorders, camcorders and decoders etc.) designed to connect to TV broadcast receiver tuner ports.

**\*\*Remarks: It is not necessary to be tested on this item.**

## 6. Differential Voltage Emissions

### 6.1 Test Setup and Procedure

#### 6.1.1 Test Setup

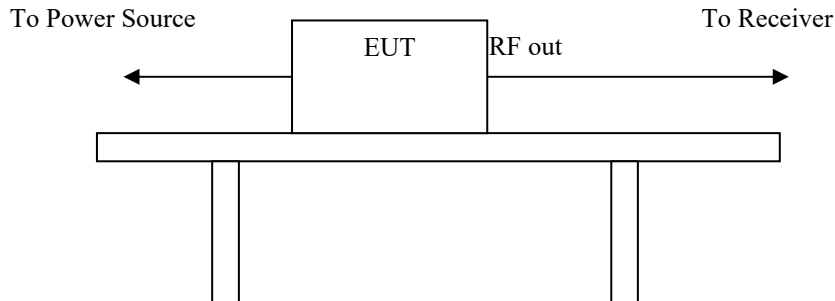

#### 6.1.2 Test Procedure

The output level of the auxiliary signal generator was set to 70dBuV at the EUT antenna terminal with 75 ohms impedance with an un-modulated carrier.

The highest emissions were analyzed in details by operating the spectrum analyzer and/or EMI receiver in quasi-peak mode to determine the precise amplitude of the emissions. The power of EUT was switched off to make sure the emission was not contributed by the auxiliary signal generator. While doing so, the interconnecting cables and major parts of the system were moved around to maximize the emission.

#### 6.1.3 EMI Receiver Configuration (for the frequencies tested)

Frequency Range:	30MHz-2150MHz
Detector Function:	Quasi-Peak Mode
Resolution Bandwidth:	120kHz

**6.1.4 Limit**

**Applicable to:**

- 1. TV broadcast receiver tuner ports with an accessible connector.**
- 2. RF modulator output ports.**
- 3. FM broadcast receiver tuner ports with an accessible connector.**

Table clause	Frequency range MHz	Detector type/ bandwidth	Class B limits dB(μV) 75 Ω			Applicability
			Other	Local Oscillator Fundamental	Local Oscillator Harmonics	
A12.1	30 – 950	For frequencies ≤1 GHz  Quasi Peak/ 120 kHz	46	46	46	See a)
	950 – 2 150		46	54	54	
A12.2	950 – 2 150		46	54	54	See b)
A12.3	30 – 300		46	54	50	See c)
	300 – 1 000	52				
A12.4	30 – 300	For frequencies ≥1 GHz	46	66	59	See d)
	300 – 1 000				52	
A12.5	30 – 950	Peak/ 1 MHz	46	76	46	See e)
	950 – 2 150			n/a	54	

a) Television receivers (analogue or digital), video recorders and PC TV broadcast receiver tuner cards working in channels between 30 MHz and 1 GHz, and digital audio receivers.

b) Tuner units (not the LNB) for satellite signal reception.

c) Frequency modulation audio receivers and PC tuner cards.

d) Frequency modulation car radios.

e) Applicable to EUTs with RF modulator output ports (for example DVD equipment, video recorders, camcorders and decoders etc.) designed to connect to TV broadcast receiver tuner ports.

**\*\*Remarks: It is not necessary to be tested on this item.**

## 7. Outdoor units of home satellite receiving systems

### 7.1 Test Setup and Procedure

#### 7.1.1 Test Setup

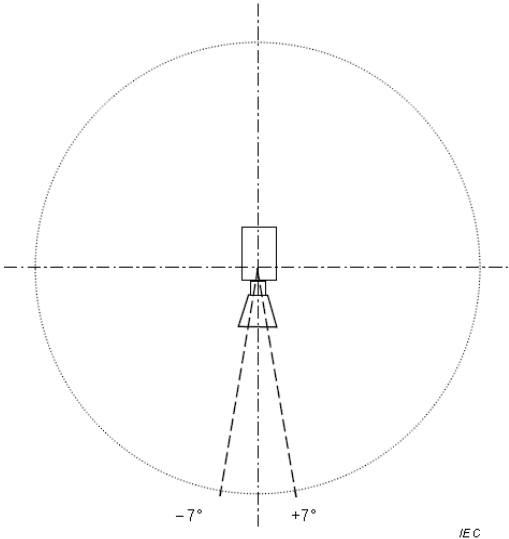
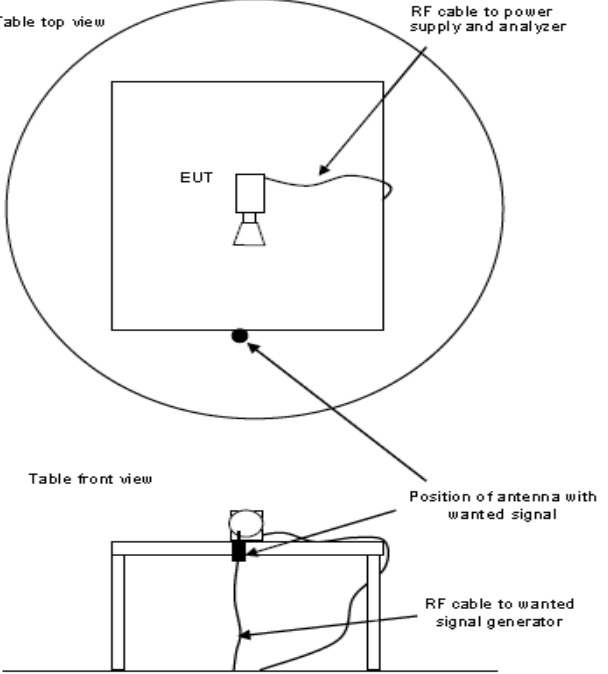
 <p style="text-align: center;">-7°      +7°</p> <p style="text-align: right;"><i>IEC</i></p>	 <p>Table top view</p> <p>RF cable to power supply and analyzer</p> <p>EUT</p> <p>Table front view</p> <p>Position of antenna with wanted signal</p> <p>RF cable to wanted signal generator</p>
<p>Description of <math>\pm 7^\circ</math> of the main beam axis of the EUT</p>	<p>Measurement arrangements of transmit antenna for the wanted signal</p>

#### 7.1.2 Test Procedure

The input signal shall be adjusted to get the maximum rated output level from the EUT. For the measurement in the frequency range from 30 MHz to 18 GHz the input signal shall be adjusted so that the output frequency is within this frequency range. For the measurement in the frequency range above 1 GHz, the frequency of the input signal shall be adjusted in such a way that the EUT is measured, as a minimum, at the lowest, middle and highest rated output frequency within the measured frequency range.

#### 7.1.3 Spectrum Analyzer Configuration (for the frequencies tested)

Frequency Range: 30MHz--1000MHz  
 Detector Function: Quasi-Peak Mode  
 Resolution Bandwidth: 120kHz

Frequency Range: Above 1000MHz  
 Detector Function: Peak/Average Mode  
 Resolution Bandwidth: 1MHz

**7.1.4 Limit**

Table Clause	Frequency Range MHz	Measurement			Class B Limits	Applicable to
		Facility (see Table A.1)	Distance m	Detector type / Bandwidth		
A7.1	30 to 1 000	SAC / OATS / FAR	See Table A.4	Quasi Peak / 120 kHz	See Table A.4	
A7.2	1 000 to 2 500	FSOATS	3	Average / 1 MHz	50 dB(μV/m)	LO leakage and spurious radiated emissions from the EUT, in the region outside ±7° of the main beam axis. See Figure H.1
	2 500 to 18 000				64 dB(μV/m)	
A7.3	1 000 to 18 000	FSOATS	3	Average / 1 MHz	37 dB(μV/m)	LO leakage from the EUT, in the region within ±7° of the main beam axis. See Figure H.1
A7.4	1 000 to 18 000	Conducted (Clause H.4)	n/a	Average / 1 MHz	30 dBpW	

For details of the EUT configuration, see Annex H.

For radiated emissions measurements at frequencies up to 1 GHz, the requirements defined in Table A.4 shall be satisfied.

Apply the appropriate limits across the entire frequency range.

Apply the limits defined in table Clause A7.1 and A7.2. Also apply the limits defined in either table Clause A7.3 or A7.4.

**\*\*Remarks: It is not necessary to be tested on this item.**

## 8. Electrostatic discharge (ESD) immunity

### 8.1 Test Specification and Setup

#### 8.1.1 Test Specification

Port:	Enclosure
Basic Standard:	EN 61000-4-2 / IEC 61000-4-2 / BS EN 61000-4-2 (details referred to Sec 1.2)
Test Level:	Air +/- 2 kV, +/- 4 kV, +/- 8 kV Contact +/- 4 kV
Criteria:	B
Test Procedure:	refer to ISL QA -T4-E-S7
Temperature:	25°C
Humidity:	40%

#### Selected Test Point

Air: discharges were applied to slots, aperture or insulating surfaces. 10 single air discharges were applied to each selected points.

Contact: 10 discharges minimum were to the selected contact points.

Indirect Contact Points: 10 discharges were applied to center of one edge of VCP and each EUT side of HCP with 10 cm away from EUT.

#### 8.1.2 Test Setup

EUT is 1m from the wall and other metallic structure. When Battery test mode is needed, a cable with one 470kΩ resistor at two rare ends is connected from metallic part of EUT and screwed to HCP.

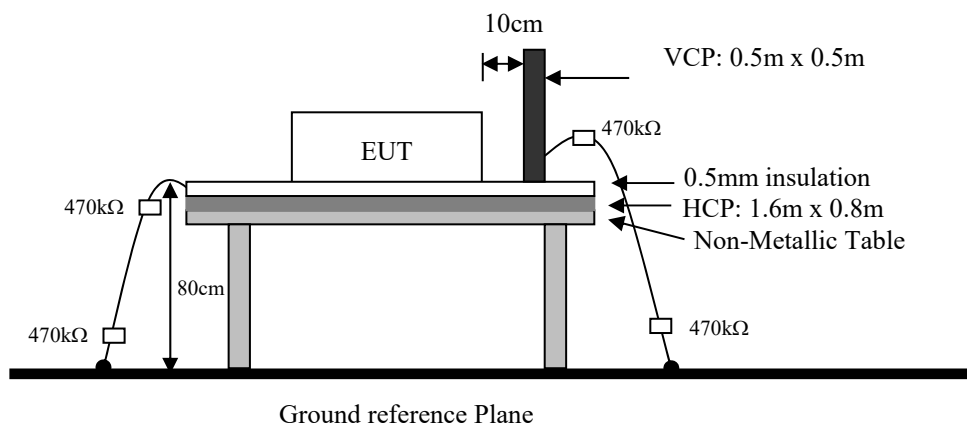

#### 8.1.3 Test Result

**Performance of EUT complies with the given specification.**

## 8.2 Test Point

Red arrow lines indicate the contact points, and blue arrow lines indicate the air points.

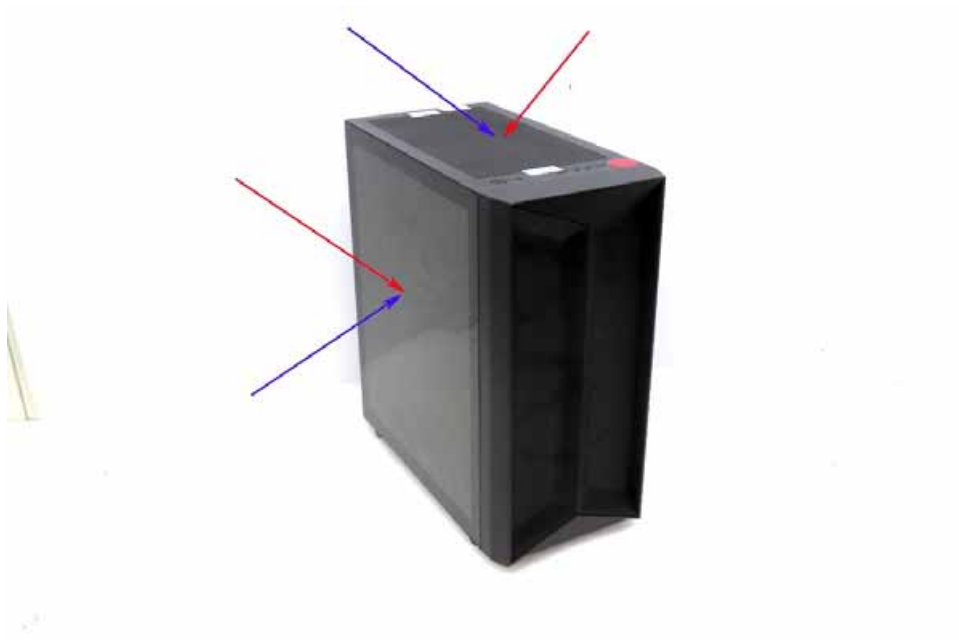

### 8.3 Test Setup Photo



## 9. Radio-Frequency, Electromagnetic Field immunity

### 9.1 Test Specification and Setup

#### 9.1.1 Test Specification

Port:	Enclosure
Basic Standard:	EN 61000-4-3 / IEC 61000-4-3 / BS EN 61000-4-3 (details referred to Sec 1.2)
Test Level:	3 V/m
Modulation:	AM 1kHz 80%
Frequency range:	80 MHz~1 GHz 1800MHz, 2600MHz, 3500MHz, 5000MHz
Frequency Step:	1% of last step frequency
Dwell time:	2s
Polarization:	Vertical and Horizontal
EUT Azimuth Angle	<input checked="" type="checkbox"/> 0° <input checked="" type="checkbox"/> 90° <input checked="" type="checkbox"/> 180° <input checked="" type="checkbox"/> 270°
Criteria:	A
Test Procedure:	refer to ISL QA -T4-E-S8
Temperature:	25°C
Humidity:	58%

#### 9.1.2 Test Setup

The field sensor is placed at one calibration grid point to check the intensity of the established fields on both polarizations. EUT is adjusted to have each side of EUT face coincident with the calibration plane. A CCD camera and speakers are used to monitor the condition of EUT for the performance judgment.

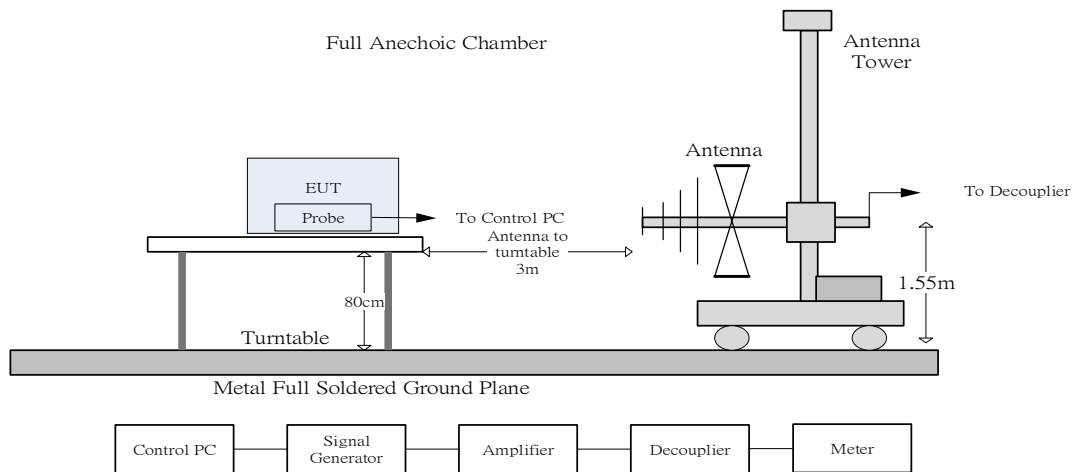

#### 9.1.3 Test Result

**Performance of EUT complies with the given specification.**

## 9.2 Test Setup Photo



## 10. Power Frequency Magnetic Field immunity

### 10.1 Test Specification and Setup

#### 10.1.1 Test Specification

Port:	Enclosure
Basic Standard:	EN 61000-4-8 / IEC 61000-4-8 / BS EN 61000-4-8 (details referred to Sec 1.2)
Test Level:	1A/m
Polarization:	X, Y, Z
Criteria:	A
Test Procedure:	refer to ISL QA -T4-E-S12
Temperature:	26°C
Humidity:	58%

#### 10.1.2 Test Setup

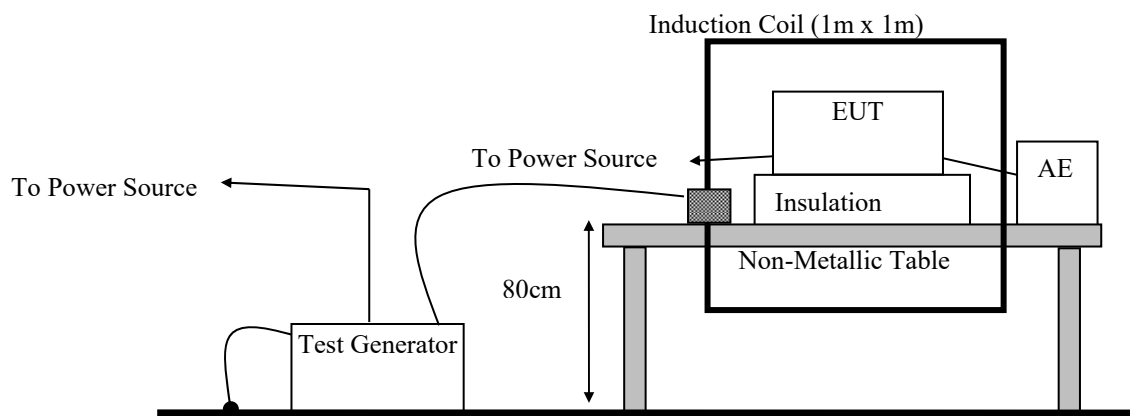

#### 10.1.3 Test Result

**Performance of EUT complies with the given specification.**

## 10.2 Test Setup Photo



# 11. Harmonics

## 11.1 Test Specification and Setup

### 11.1.1 Test Specification

Port:	AC mains
Active Input Power:	<75W
Basic Standard:	EN IEC 61000-3-2 / IEC 61000-3-2 / BS EN IEC 61000-3-2 (details referred to Sec 1.2)
Test Duration:	2.5min
Class:	A
Test Procedure:	refer to ISL QA -T4-E-S14
Temperature:	25°C
Humidity:	58%

### Test Procedure

The EUT is supplied in series with shunts or current transformers from a source having the same nominal voltage and frequency as the rated supply voltage and frequency of the EUT. The EUT is configured to its rated current with additional resistive load when the testing is performed.

Equipment having more than one rated voltage shall be tested at the rated voltage producing the highest harmonics as compared with the limits.

### 11.1.2 Test Setup

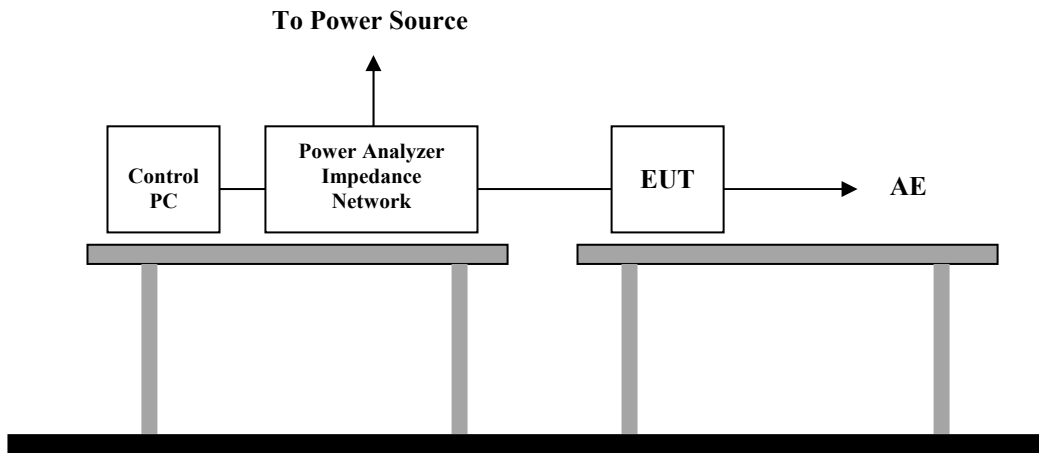

### 11.1.3 Limit

#### Limits of Class A Harmonics Currents

Harmonics Order n	Maximum Permissible harmonic current A	Harmonics Order n	Maximum Permissible harmonic current A
Odd harmonics		Even harmonics	
3	2.30	2	1.08
5	1.14	4	0.43
7	0.77	6	0.30
9	0.40	$8 \leq n \leq 40$	$0.23 * 8/n$
11	0.33		
13	0.21		
$15 \leq n \leq 39$	$0.15 * 15/n$		

### 11.1.4 Test Result

**Active input power under 75W, no limit apply, declare compliance.**

## 12. Voltage Fluctuations

### 12.1 Test Specification and Setup

#### 12.1.1 Test Specification

Port:	AC mains
Basic Standard:	EN 61000-3-3 / IEC 61000-3-3 / BS EN 61000-3-3 (details referred to Sec 1.2)
Test Procedure:	refer to ISL QA -T4-E-S14
Observation period:	For Pst 10min For Plt 2 hours
Temperature:	25°C
Humidity:	58%

#### Test Procedure

The EUT is supplied in series with reference impedance from a power source with the voltage and frequency as the nominal supply voltage and frequency of the EUT.

#### 12.1.2 Test Setup

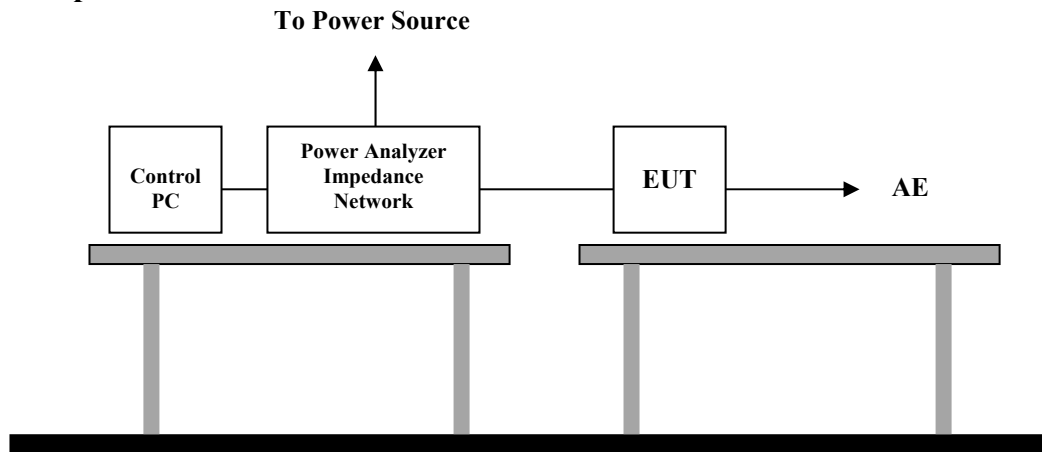

#### 12.1.3 Test Result

**Performance of EUT complies with the given specification.**

### 12.2 Test Data: Configuration 1

Test File: F-20220629\_013  
Test Standard: Test per IEC 61000-3-3 Ed. 3.1 : 2017  
Test Class: Flicker Test, All Parameters  
Test Result: PASS

Test Duration (min): 10

Source Qualification: Compliance with IEC 61000-3-3 Ed. 3.1 : 2017

#### Phase A

Vrms (Volts):	230.83	Frequency (Hz):	50.00
I_rms (Amps):	0.157	Power (W):	24.2
V-THD (%):	0.354	T-Max (ms):	0 (500)
dmax (%):	0.000 (4.000)	Hi dmax (%):	0.000 (4.000)
dc (%):	0.000 (3.300)	Hi dc (%):	0.000 (3.300)
Pst-1 :	0.039 (1.000)		
Plt :	0.017 (0.650)		

#### Pst Spectrum

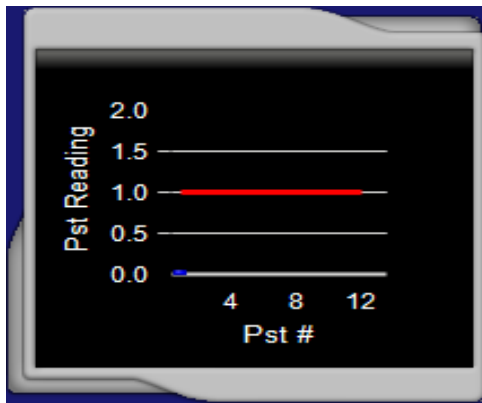

#### Plt Spectrum

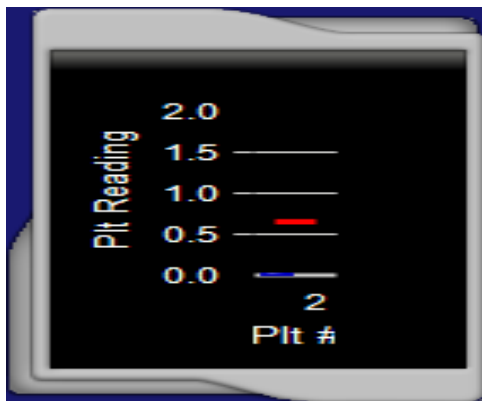

### 12.3 Test Setup Photo



## 13. Appendix

### 13.1 Appendix A: Test Equipment

#### 13.1.1 Test Equipment List

Location	Equipment Name	Brand	Model	S/N	Last Cal. Date	Next Cal. Date
Conduction 03	EMI Receiver 18	ROHDE&SCHWARZ	ESCI	101392	06/01/2022	06/01/2023
Conduction 03	Chamber05 -1 Cable	WOKEN	CFD 300-NL	Chamber05 -1 Cable	08/30/2021	08/30/2022
Conduction 03	LISN 19	R&S	ENV216	101425	11/11/2021	11/11/2022
Conduction 03	LISN 22	R&S	ENV216	101478	10/28/2021	10/28/2022

Location Chmb12	Equipment Name	Brand	Model	S/N	Last Cal. Date	Next Cal. Date
Radiation	BILOG Antenna 18	Schwarzbeck	Schwarzbeck VULB 9168+EMCI-N-6-05	646	03/09/2022	03/09/2023
Radiation	Preamplifier 26	EMCI	EMC9135	980297	02/23/2022	02/23/2023
Radiation	Coaxial Cable Chmb 12-10M-01	PEWC	CFD400-NL	Chmb 12-10M-01	10/13/2021	10/13/2022
Radiation	EMI Receiver 19	ROHDE & SCHWARZ	ESR 3	102460	07/21/2021	07/21/2022

Location Chmb14	Equipment Name	Brand	Model	S/N	Last Cal. Date	Next Cal. Date
Rad. Above 1GHz	Spectrum Analyzer 25	R&S	FSV 40	101499	10/29/2021	10/29/2022
Rad. Above 1GHz	Horn Antenna 06	ETS-Lindgren	3117	00066665	12/20/2021	12/20/2022
Rad. Above 1GHz	Preamplifier 20	EMC INSTRUMENT	EMC051845	980084	11/16/2021	11/16/2022
Rad. Above 1GHz	Microwave Cable 11	HUBER SUHNER	SUCOFLEX 106	78034/6	03/09/2022	03/09/2023
Rad. Above 1GHz	Microwave Cable 26	EMCI	EMC104-NM-SM-800	141112	03/09/2022	03/09/2023

Location	Equipment Name	Brand	Model	S/N	Last Cal. Date	Next Cal. Date
EN61K-4-2	ESD Gun 07	NoiseKen	ESS-2002EX	ESS0878638	01/14/2022	01/14/2023
EN61K-4-3	Broadband Log-Periodic Antenna	AR	AT1080	310698	N/A	N/A
EN61K-4-3	Horn Antenna RF-01	AR	ATS700M11G	0335864	N/A	N/A
EN61K-4-3	Amplifier 80Mz~1GHz 250W	AR	250W1000C	358877	N/A	N/A
EN61K-4-3	Amplifier 0.7~6GHz 60W	AR	60S1G6	358973	N/A	N/A
EN61K-4-3	Broadband Coupler 80M~1GHz	Amplifier Research	DC6180A	0341805	N/A	N/A
EN61K-4-3	Coaxial Cable	INSULATED	NPS-4806-2360-NP3	108599.003.01.03	N/A	N/A
EN61K-4-3	Broadband Coupler 0.8G~4.26GHz	AR	DC7144A	0335226	N/A	N/A
EN61K-4-3	Broadband Coupler 4G~8GHz	AR	DC7350A	0335817	N/A	N/A
EN61K-4-3	Signal Generator 07	ROHDE & SCHWARZ	SMB100A	107780	11/23/2021	11/23/2022
EN61K-4-8	Magnetic Field Test Generator	FCC	F-1000-4-8-G-12 5A	01038	05/30/2022	05/30/2023
EN61K-3-2/3, EN61K-3-11-12	Harmonics & Flickers Test System 04	PACIFIC*APS	ECTS2-3450F-n	550072	04/20/2022	04/20/2023

PS: N/A => The equipment does not need calibration.

**\*\*Software for Controlling Spectrum/Receiver and Calculating Test Data**

Test Item	Filename	Version
EN IEC 61000-3-2	HFa-16 Program	v1.0.0.9
EN 61000-3-3	HFa-16 Program	v1.0.0.9
EN 61000-4-2	N/A	2.0
EN 61000-4-3	i2	529b
EN 61000-4-8	N/A	

Site	Filename	Version
Conduction/Radiation	EZ EMC	ISL-03A2

### 13.2 Appendix B: Uncertainty of Measurement

The laboratory measurement uncertainty accordance with refers to CISPR 16-4-2. If U<sub>lab</sub> is less than or equal to U<sub>cispr</sub> in Table 1, then the test report may either state the value of U<sub>lab</sub> or state that U<sub>lab</sub> is less than U<sub>cispr</sub>.

The coverage factor k = 2 yields approximately a 95 % level of confidence.

<Conduction 03>

AMN: ± 2.90dB

<Chamber 12 (10m)>

Horizontal

30MHz~200MHz: ±4.56dB

200MHz~1000MHz: ±4.20dB

Vertical

30MHz~200MHz: ±4.58dB

200MHz~1000MHz: ±4.78dB

<Chamber 14 (3m)>

1GHz~6GHz: ±5.06dB

<Immunity 02>

Test item	Uncertainty	Test item	Uncertainty
EN 61000-4-2 (ESD)		EN 61000-4-8 (Magnetic)	5.49 %
Peak current I <sub>p</sub>	≤ 4.83%	EN IEC 61000-3-2 (Harmonics)	0.43 %
current at 30 ns	≤ 4.84%	EN 61000-3-3 (Fluctuations and Flicker)	8 %
current at 60 ns	≤ 4.84%		
EN 61000-4-3 (RS)	2.66 dB		

### 13.3 Appendix C: Photographs of EUT

Please refer to the File of **ISL-22LE0475P**

--- END ---