

TEST REPORT

of

EN 55032 / CISPR 32 / BS EN 55032
AS/NZS CISPR 32 Class B
EN 55035 / CISPR 35 / BS EN 55035 IMMUNITY
EN IEC 61000-3-2 / BS EN IEC 61000-3-2
EN 61000-3-3 / BS EN 61000-3-3

Product: **D200P E3.S**
Main Model: **PX1AE-E3SX**
Series Model: **NA**
Brand: **Apacer**
Applicant: **Apacer Technology Inc.**
Address: **1F., No.32, Zhongcheng Rd., Tucheng Dist.,
New Taipei City 236, Taiwan , R.O.C.**

Test Performed by:



International Standards Laboratory Corp. LT Lab.

TEL: +886-3-263-8888 FAX: +886-3-263-8899

No. 120, Lane 180, Hsin Ho Rd., Lung-Tan Dist., Tao Yuan City 325, Taiwan

Report No.: **ISL-24LE0335CE35-R1-MA**
Issue Date : **May 20, 2025**



Test results given in this report apply only to the specific sample(s) tested and are traceable to national or international standard through calibration of the equipment and evaluating measurement uncertainty herein. According to customer agreement, the laboratory issues test reports based on the regulations or standards specifications, the measurement uncertainty is not considered in conformity decision rules. This test report shall not be reproduced except in full, without the written approval of International Standards Laboratory Corp.

Contents of Report



1.	General	1
1.1	Certification of Accuracy of Test Data.....	1
1.2	Test Standards.....	2
1.3	Description of EUT.....	5
1.4	Description of Support Equipment	6
1.5	Software for Controlling Support Unit	7
1.6	I/O Cable Condition of EUT and Support Units	8
2.	Power Main Port Conducted Emissions.....	9
2.1	Test Setup and Procedure	9
2.2	Conduction Test Data: Configuration 1	11
2.3	Test Setup Photo	13
3.	Telecommunication Port Conducted Emissions	15
3.1	Test Setup and Procedure	15
4.	Radiated Disturbance Emissions.....	17
4.1	Test Setup and Procedure	17
4.2	Limit	19
4.3	Radiation Test Data: Configuration 1	21
4.4	Test Setup Photo	26
5.	Voltage Disturbance Emissions at Antenna Terminals.....	28
5.1	Test Setup and Procedure	28
6.	Differential Voltage Emissions	30
6.1	Test Setup and Procedure	30
7.	Outdoor units of home satellite receiving systems	32
7.1	Test Setup and Procedure	32
8.	Electrostatic discharge immunity.....	34
8.1	Test Specification and Setup.....	34
8.2	Test Point.....	35
8.3	Test Setup Photo	36
9.	Radiated, radio-frequency, electromagnetic field immunity.....	37
9.1	Test Specification and Setup.....	37
9.2	Test Setup Photo	38
10.	Electrical fast transient/burst immunity	39
10.1	Test Specification and Setup	39
10.2	Test Setup Photo.....	41
11.	Surge immunity.....	42
11.1	Test Specification and Setup	42
11.2	Test Setup Photo.....	43
12.	Immunity to conducted disturbances	44
12.1	Test Specification and Setup	44
12.2	Test Setup Photo.....	45
13.	Power frequency magnetic field immunity	46
13.1	Test Specification and Setup	46
13.2	Test Setup Photo.....	47
14.	Voltage dips, short interruptions and voltage variations immunity	48
14.1	Test Specification and Setup	48
14.2	Test Setup Photo.....	49

Contents of Report

15.	Harmonics	50
15.1	Test Specification and Setup	50
16.	Voltage fluctuations and flicker	52
16.1	Test Specification and Setup	52
16.2	Test Data.....	53
16.3	Test Setup Photo.....	54
16.4	Appendix	55
16.5	Appendix A: Test Equipment.....	55
16.6	Appendix B: Uncertainty of Measurement.....	58
16.7	Appendix C: Photographs of EUT	59

1. General

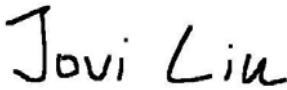
1.1 Certification of Accuracy of Test Data

Standards:	Please refer to 1.2
Equipment Tested:	D200P E3.S
Main Model:	PX1AE-E3SX
Series Model:	NA
Brand:	Apacer
Applicant:	Apacer Technology Inc.
Sample received Date:	May 14, 2025
Final test Date:	EMI: refer to the date of test data EMS: May 17, 2024
Test Site:	Chamber 02; Chamber 14; Conduction 03; Immunity 02
Test Distance:	10m; 3m (above 1GHz) (EMI test)
Temperature:	refer to each site test data
Humidity:	refer to each site test data
Atmospheric Pressure:	86 kPa to 106 kPa
Input power:	Conduction input power: AC 230 V / 50 Hz Radiation input power: AC 230 V / 50 Hz Immunity input power: AC 230 V / 50 Hz
Test Result:	PASS
Report Engineer:	Elly Duan
Test Engineer:	 _____ Jovi Liu
Approved By:	 _____ Angus Chu / Sr. Manager

1.2 Test Standards

The tests which this report describes were conducted by an independent electromagnetic compatibility consultant, International Standards Laboratory Corp. in accordance with the following

EN 55032:2015+A11:2020 and EN 55032:2015+A1:2020 and CISPR 32:2015+A1:2019 and BS EN 55032:2015+A11:2020 and BS EN 55032:2015+A1:2020 Class B Electromagnetic compatibility of multimedia equipment - Emission requirements.

AS/NZS CISPR 32:2015+A1:2020 Class B Electromagnetic compatibility of multimedia equipment- Emission requirements

Performed Item	Test Performed	Deviation	Result
Conducted emissions from the AC mains power ports	Yes	No	PASS
Telecommunication Port Conducted Emissions (asymmetric mode)	N/A	N/A	N/A
Radiated emissions at frequencies below 1 GHz	Yes	No	PASS
Radiated emissions at frequencies above 1 GHz	Yes	No	PASS
Radiated emissions from FM receivers	N/A	N/A	N/A
Voltage Disturbance Emissions at Antenna Terminals	N/A	N/A	N/A
Differential voltage emissions	N/A	N/A	N/A
Outdoor units of home satellite receiving systems	N/A	N/A	N/A

EN 55035:2017+A11:2020 and CISPR 35:2016 modified and BS EN 55035: 2017+A11:2020
Electromagnetic compatibility of multimedia equipment - Immunity requirements.

Standard	Description	Results	Criteria
EN 61000-4-2:2009 IEC 61000-4-2:2008 BS EN 61000-4-2:2009	Electrostatic discharge immunity	Pass	B
EN IEC 61000-4-3:2020 IEC 61000-4-3:2020 BS EN IEC 61000-4-3:2020	Radiated, radio-frequency, electromagnetic field immunity	Pass	A
EN 61000-4-4:2012 IEC 61000-4-4:2012 BS EN 61000-4-4:2012	Electrical fast transient/burst immunity	Pass	B
EN 61000-4-5:2014+A1:2017 IEC 61000-4-5:2014+A1:2017 BS EN 61000-4-5:2014+A1:2017	Surge immunity	Pass	B
EN IEC 61000-4-6:2023 IEC 61000-4-6:2023 BS EN IEC 61000-4-6:2023	Immunity to conducted disturbances	Pass	A
EN 61000-4-8:2010 IEC 61000-4-8:2009 BS EN 61000-4-8:2010	Power frequency magnetic field immunity	Pass	A
EN IEC 61000-4-11:2020+AC:2022 IEC 61000-4-11:2020+COR2:2022 BS EN IEC 61000-4-11:2020+AC:2022	Voltage dips, short interruptions and voltage variations immunity		
	>95% in 0.5 cycle	Pass	B
	30% in 25 cycle	Pass	C
	>95% in 250 cycle	Pass	C

Standard	Description	Results
EN 61000-3-2:2014 IEC 61000-3-2:2014 EN IEC 61000-3-2:2019+A1:2021 IEC 61000-3-2:2018+A1:2020+ISH1:2021 BS EN IEC 61000-3-2:2019+A1:2021	Limits for harmonic current emissions (equipment input current $\leq 16A$ per phase)	Pass
EN 61000-3-3:2013 IEC 61000-3-3:2013 EN 61000-3-3:2013+A2:2021+AC:2022 IEC 61000-3-3:2013+A2:2021+COR1:2022 BS EN 61000-3-3:2013+A2:2021+AC:2022	Limits for voltage fluctuations and flicker in low-voltage supply systems (equipment with input current $\leq 16 A$ per phase)	Pass

1.2.1 Performance Criteria for Compliance: EN 55035 and BS EN 55035

Performance criterion A

The equipment shall continue to operate as intended without operator intervention. No degradation of performance, loss of function or change of operating state is allowed below a performance level specified by the manufacturer when the equipment is used as intended. The performance level may be replaced by a permissible loss of performance. If the minimum performance level or the permissible performance loss is not specified by the manufacturer, then either of these may be derived from the product description and documentation, and by what the user may reasonably expect from the equipment if used as intended.

Performance criterion B

During the application of the disturbance, degradation of performance is allowed. However, no unintended change of actual operating state or stored data is allowed to persist after the test.

After the test, the equipment shall continue to operate as intended without operator intervention; no degradation of performance or loss of function is allowed, below a performance level specified by the manufacturer, when the equipment is used as intended. The performance level may be replaced by a permissible loss of performance.

If the minimum performance level (or the permissible performance loss), or recovery time, is not specified by the manufacturer, then either of these may be derived from the product description and documentation, and by what the user may reasonably expect from the equipment if used as intended.

Performance criterion C

Loss of function is allowed, provided the function is self-recoverable, or can be restored by the operation of the controls by the user in accordance with the manufacturer's instructions. A reboot or re-start operation is allowed.

Information stored in non-volatile memory, or protected by a battery backup, shall not be lost.

1.3 Description of EUT

EUT

This report test data using the report number ISL-24LE0335CE35-R1

Description	D200P E3.S
Condition	Pre-Production
Main Model	PX1AE-E3SX
Serial Number	N/A
Power	From Personal Computer Supply
Control IC	PS5302
PCB Number	Q1080X23X00G402H; Q1080X23X00G40XX-XXXXXX(X=0~9;A~Z,or Blank)
Memory Capacity	1GB-16TB
Highest working frequency	16GHz

The representative configuration of memory capacity in the test report is specified by the manufacturer as the maximum capacity for testing in this report.

Test configuration:

Configuration	Control IC	PCB Number	Memory Capacity
1	PS5302	Q1080X23X00G402H	16TB

PCB Number Difference:

Model	Market
Q1080X23X00G402H; Q1080X23X00G40XX-XXXXXX(X=0~9;A~Z,or Blank)	Difference Market

EMI Noise Source:

Refer to the photo	Control IC	Point
EUT-5	PS5302	U1
Refer to the photo	Crystal	Point
EUT-6	25MHz	Y1

EMI Solution:

NA

1.4 Description of Support Equipment

For EMI test Configuration Support unit: 1~6

For EMS test Configuration Support unit: 4~9

No	Unit	Model / Serial No.	Brand	Power Cord	FCC ID
1	WD Type-C HDD	My Passport Ultra S/N: N/A	WD	N/A	FCC DOC
2	USB Keyboard	KB216 S/N: N/A	DELL	N/A	FCC DOC
3	USB Mouse	MS116 S/N: N/A	DELL	N/A	FCC DOC
4	Printer	C930 S/N: N/A	HP	Non-shielded	FCC DOC
5	LCD Monitor	P2416D S/N: N/A	DELL	Non-shielded	FCC DOC
6	Personal Computer	B550 S/N: N/A	Gigabyte	Non-shielded	FCC DOC
7	USB Keyboard	SK-8175 S/N: N/A	DELL	N/A	FCC DOC
8	USB Mouse	MOCZUL S/N: N/A	DELL	N/A	FCC DOC
9	AKiTiO Type-C HDD	SK2-U31AS-AKT S/N: N/A	AKiTiO	N/A	FCC DOC

1.5 Software for Controlling Support Unit

Test programs exercising various part of EUT were used. The programs were executed as follows:

For EMI test configuration:

1. PC running WINTHRAX to read and write the EUT.
2. Send signal to the Printer through PC USB Port.
3. Read and write WD Type-C HDD through PC USB Port.
4. Send Color Bar to the LCD Monitor through PC HDMI Port.
5. Repeat the above steps.

	Filename	Version
EUT	WINTHRAX	3.09.02
LCD Monitor	Windows Media Player	12.0
Printer	IntelEMC	1.1
WD Type-C HDD	IntelEMC	1.1

For EMS test configuration:

1. PC running WINTHRAX to read and write the EUT.
2. Send signal to the Printer through PC USB Port.
3. Read and write AKiTIO Type-C HDD through PC USB Port.
4. Send Color Bar to the LCD Monitor through PC HDMI Port.
5. Repeat the above steps.

	Filename	Version
EUT	WINTHRAX	3.09.02
LCD Monitor	Windows Media Player	12.0
Printer	IntelEMC	1.1
AKiTIO Type-C HDD	IntelEMC	1.1

1.6 I/O Cable Condition of EUT and Support Units

For EMI test configuration:

Description	Path	Length	Shielding	Core	Remark
AC Power Cable	100V~240V to PC SPS	1.8m	No	No	
HDMI Cable	LCD Monitor HDMI Port to PC HDMI Port	1.8m	Yes	No	
USB Keyboard Data Cable	USB Keyboard to PC USB Port	1.8m	Yes	No	
USB Mouse Data Cable	USB Mouse to PC USB Port	1.8m	Yes	No	
USB data cable	Printer to PC USB Port	1.8m	Yes	No	
USB data cable	WD Type-C HDD to PC USB Port	1.5m	Yes	No	

For EMS test configuration:

Description	Path	Length	Shielding	Core	Remark
AC Power Cable	100V~240V to PC SPS	1.8m	No	No	
HDMI Cable	LCD Monitor HDMI Port to PC HDMI Port	1.8m	Yes	No	
USB Keyboard Data Cable	USB Keyboard to PC USB Port	1.8m	Yes	No	
USB Mouse Data Cable	USB Mouse to PC USB Port	1.8m	Yes	No	
USB data cable	Printer to PC USB Port	1.8m	Yes	No	
USB data cable	AKiTIO Type-C HDD to PC USB Port	1.0m	Yes	No	

2. Power Main Port Conducted Emissions

2.1 Test Setup and Procedure

2.1.1 Test Setup

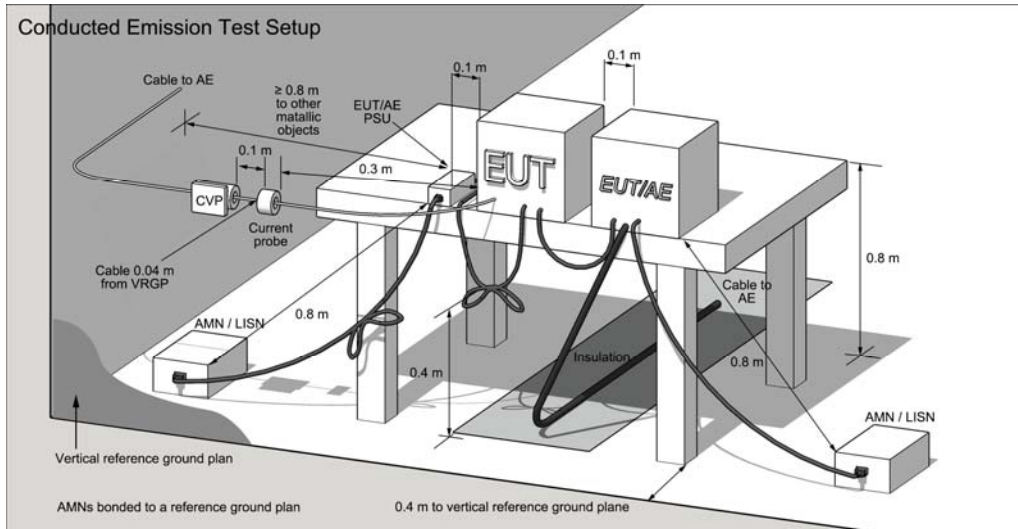

2.1.2 Test Procedure

The measurements are performed in a shielded room test site. The EUT was placed on non-conduction 1.0m x 1.5m table, which is 0.8 meters above an earth-grounded.

Power to the EUT was provided through the AMN which has the Impedance (50ohm/50uH) vs. Frequency Characteristic in accordance with the standard. Power to the AMNs were filtered to eliminate ambient signal interference and these filters were bonded to the ground plane. Peripheral equipment required to provide a functional system (support equipment) for EUT testing was powered from the second AMN through a ganged, metal power outlet box which is bonded to the ground plane at the AMN.

The interconnecting cables were arranged and moved to get the maximum measurement. Both the line of power cord, live and neutral, were measured. All of the interface cables were manipulated according to EN 55032 / BS EN 55032 requirements.

The highest emissions were analyzed in details by operating the spectrum analyzer in fixed tuned mode to determine the nature of the emissions and to provide information which could be useful in reducing their amplitude.

2.1.3 EMI Receiver/Spectrum Analyzer Configuration (for the frequencies tested)

Frequency Range:	150kHz--30MHz
Detector Function:	Quasi-Peak / Average Mode
Resolution Bandwidth:	9kHz

2.1.4 Limit

Conducted emissions from the AC mains power ports of Class_A equipment:

Frequency	QP	AV
MHz	dB(μ V)	dB(μ V)
0.15-0.50	79	66
0.50-30	73	60
Note: The lower limit shall apply at the transition frequencies		

Conducted emissions from the AC mains power ports of Class_B equipment:

Frequency	QP	AV
MHz	dB(μ V)	dB(μ V)
0.15-0.50	66-56	56-46
0.50-5.0	56	46
5.0-30	60	50
Note: The lower limit shall apply at the transition frequencies		

2.2 Conduction Test Data: Configuration 1

-Live

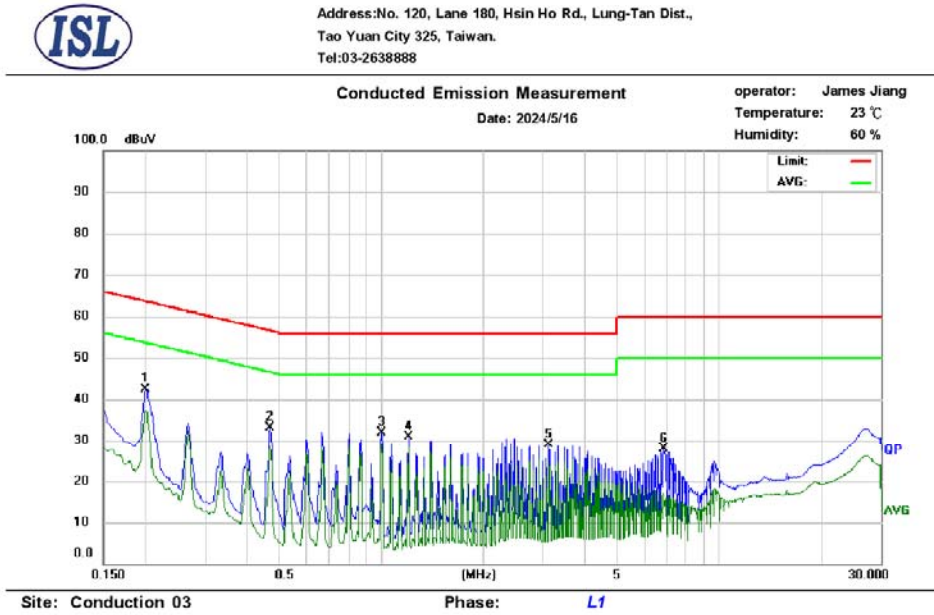

No.	Frequency (MHz)	QP_R (dBuV)	AVG_R (dBuV)	Correct Factor (dB)	QP Emission (dBuV)	QP Limit (dBuV)	QP Margin (dB)	AVG Emission (dBuV)	AVG Limit (dBuV)	AVG Margin (dB)
1*	0.200	32.58	27.60	9.69	42.27	63.63	-21.36	37.29	53.63	-16.34
2	0.467	23.39	18.97	9.70	33.09	56.56	-23.47	28.67	46.56	-17.89
3	1.000	22.10	19.40	9.72	31.82	56.00	-24.18	29.12	46.00	-16.88
4	1.201	21.23	18.36	9.73	30.96	56.00	-25.04	28.09	46.00	-17.91
5	3.138	18.97	15.41	9.80	28.77	56.00	-27.23	25.21	46.00	-20.79
6	6.875	18.03	7.32	9.87	27.90	60.00	-32.10	17.19	50.00	-32.81

Note:
 Margin = QP/AVG Emission - Limit
 QP/AVG Emission = QP_R/AVG_R + Correct Factor
 Correct Factor = LISN Loss + Cable Loss
 A margin of -8dB means that the emission is 8dB below the limit

- Neutral



Address: No. 120, Lane 180, Hsin Ho Rd., Lung-Tan Dist.,
Tao Yuan City 325, Taiwan.
Tel: 03-2638888

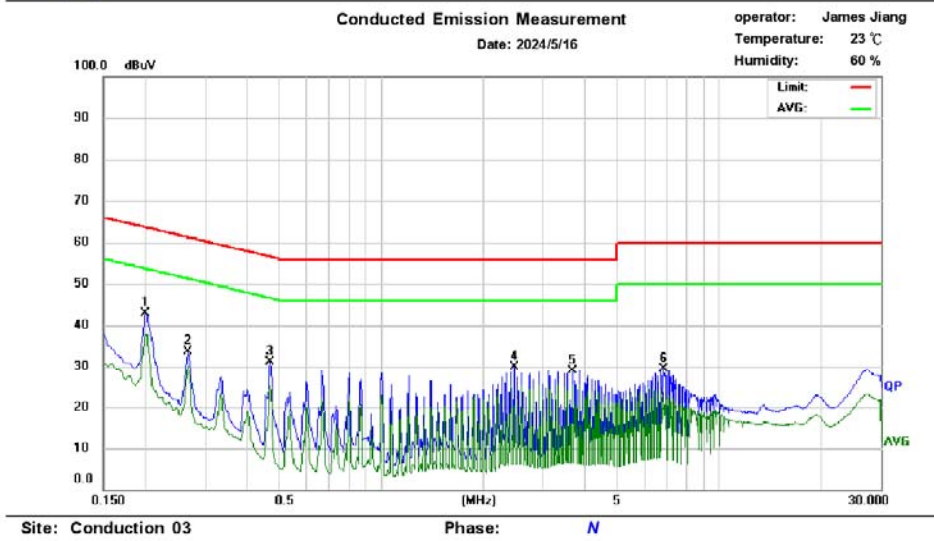

No.	Frequency (MHz)	QP_R (dBuV)	AVG_R (dBuV)	Correct Factor (dB)	QP Emission (dBuV)	QP Limit (dBuV)	QP Margin (dB)	AVG Emission (dBuV)	AVG Limit (dBuV)	AVG Margin (dB)
1*	0.200	33.05	28.25	9.70	42.75	63.63	-20.88	37.95	53.63	-15.68
2	0.267	23.89	20.45	9.70	33.59	61.21	-27.62	30.15	51.21	-21.06
3	0.467	21.33	15.36	9.70	31.03	56.56	-25.53	25.06	46.56	-21.50
4	2.470	20.07	10.53	9.78	29.85	56.00	-26.15	20.31	46.00	-25.69
5	3.671	19.10	15.66	9.81	28.91	56.00	-27.09	25.47	46.00	-20.53
6	6.875	19.56	13.68	9.88	29.44	60.00	-30.56	23.56	50.00	-26.44

Note:
 Margin = QP/AVG Emission - Limit
 QP/AVG Emission = QP_R/AVG_R + Correct Factor
 Correct Factor = LISN Loss + Cable Loss
 A margin of -8dB means that the emission is 8dB below the limit

2.3 Test Setup Photo

Front View



Back View



3.1.4 Limit

Asymmetric mode conducted emissions from Class_A equipment:

Applicable to

1. wired network ports.
2. optical fiber ports with metallic shield or tension members.
3. antenna ports.

Frequency range MHz	Coupling device	Detector type / bandwidth	Class_A voltage limits dB(μ V)	Class_A current limits dB(μ A)
0.15-0.5	AAN	Quasi Peak / 9 kHz	97-87	n/a
0.5-30			87	
0.15-0.5	AAN	Average / 9 kHz	84-74	
0.5-30			74	
0.15-0.5	CVP and current probe	Quasi Peak / 9 kHz	97-87	53-43
0.5-30			87	43
0.15-0.5	CVP and current probe	Average / 9 kHz	84-74	40-30
0.5-30			74	30
0.15-0.5	Current Probe	Quasi Peak / 9 kHz	n/a	53-43
0.5-30				43
0.15-0.5	Current Probe	Average / 9 kHz		40-30
0.5-30				30

Asymmetric mode conducted emissions from Class_B equipment:

Applicable to:

1. wired network ports.
2. optical fiber ports with metallic shield or tension members.
3. broadcast receiver tuner ports.
4. antenna ports.

Frequency range MHz	Coupling device	Detector type / bandwidth	Class_B voltage limits dB(μ V)	Class_B current limits dB(μ A)
0.15-0.5	AAN	Quasi Peak / 9 kHz	84-74	n/a
0.5-30			74	
0.15-0.5	AAN	Average / 9 kHz	74-64	
0.5-30			64	
0.15-0.5	CVP and current probe	Quasi Peak / 9 kHz	84-74	40-30
0.5-30			74	30
0.15-0.5	CVP and current probe	Average / 9 kHz	74-64	30-20
0.5-30			64	20
0.15-0.5	Current Probe	Quasi Peak / 9 kHz	n/a	40-30
0.5-30				30
0.15-0.5	Current Probe	Average / 9 kHz		30-20
0.5-30				20

****Remarks: It is not necessary to be tested on this item.**

4. Radiated Disturbance Emissions

4.1 Test Setup and Procedure

4.1.1 Test Setup

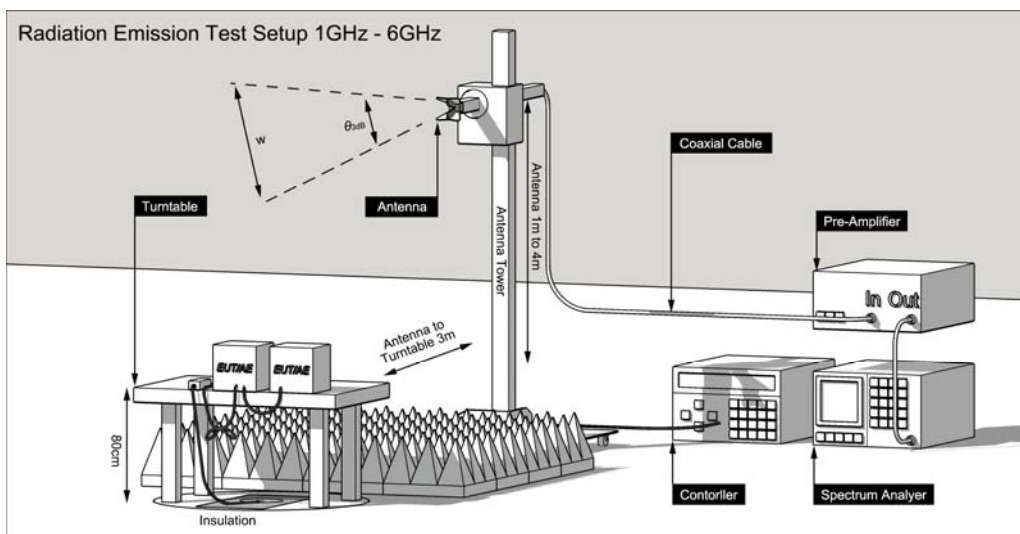
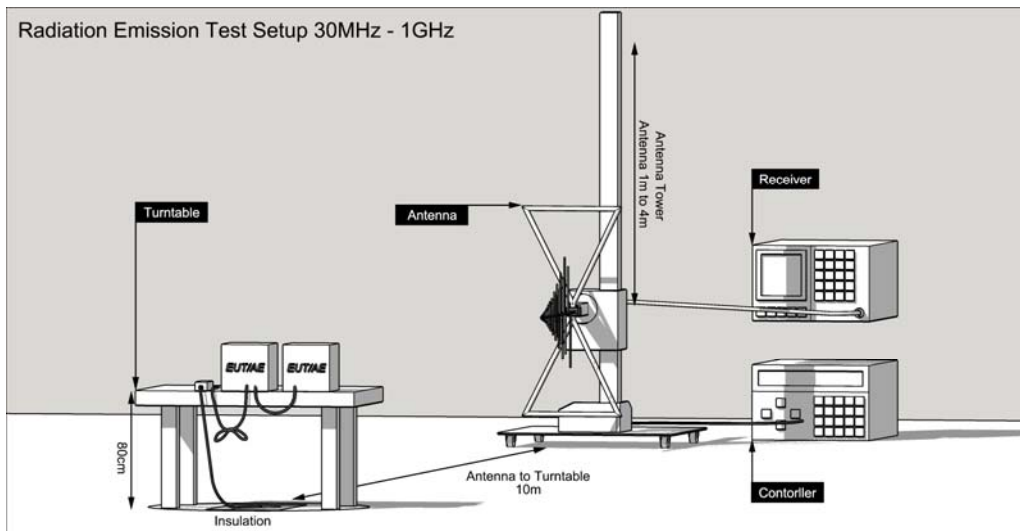
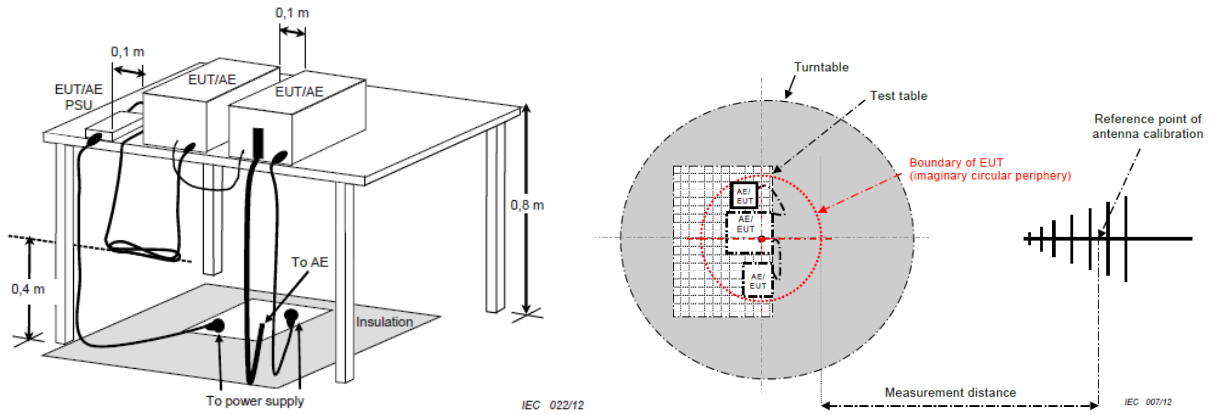

The 3dB beam width of the horn antenna used for the test is as shown in the table below.

Frequency (GHz)	E-plane	H-plane	$\theta_{3dB}(\text{min})$	d= 3 m
				w (m)
1	88°	147°	88°	5.79
2	68°	119°	68°	4.04
3	73°	92°	73°	4.44
4	70°	89°	70°	4.20
5	55°	60°	55°	3.12
6	63°	62°	62°	3.60

4.1.2 Test Procedure

The radiated emissions test will then be repeated on the chamber to measure the amplitudes accurately and without the multiple reflections existing in the shielded room. The EUT and support equipment are set up on the turntable of one of 10 meter chamber. Desktop EUT are set up on a FRP stand 0.8 meter above the ground or floor-standing arrangement shall be placed on the horizontal ground reference plane.

For the initial measurements, the receiving antenna is varied from 1-4 meter height and is changed in the vertical plane from vertical to horizontal polarization at each frequency. The highest emissions between 30 MHz to 1000 MHz were analyzed in details by operating the spectrum analyzer and/or EMI receiver in quasi-peak mode to determine the precise amplitude of the emissions. The highest emissions between 1 GHz to 6 GHz were analyzed in details by operating the spectrum analyzer in peak and average mode to determine the precise amplitude of the emissions. The test volume for a height of up to 30 cm may be obstructed by absorber placed on the ground plane.

At the highest amplitudes observed, the EUT is rotated in the horizontal plane while changing the antenna polarization in the vertical plane to maximize the reading. The interconnecting cables were arranged and moved to get the maximum measurement. Once the maximum reading is obtained, the antenna elevation and polarization will be varied between specified limits to maximize the readings. All of the interface cables were manipulated according to EN 55032 / BS EN 55032 requirements.

The highest internal source of an EUT is defined as the highest frequency generated or used within the EUT or on which the EUT operates or tunes.

If the highest frequency of the internal sources of the EUT is less than 108 MHz, the measurement shall only be made up to 1 GHz.

If the highest frequency of the internal sources of the EUT is between 108 MHz and 500 MHz, the measurement shall only be made up to 2 GHz.

If the highest frequency of the internal sources of the EUT is between 500 MHz and 1 GHz, the measurement shall only be made up to 5 GHz.

If the highest frequency of the internal sources of the EUT is above 1 GHz, the measurement shall be made up to 5 times the highest frequency or 6 GHz, whichever is less.

4.1.3 Spectrum Analyzer Configuration (for the frequencies tested)

Frequency Range: 30MHz--1000MHz
 Detector Function: Quasi-Peak Mode
 Resolution Bandwidth: 120kHz

Frequency Range: Above 1 GHz to 6 GHz
 Detector Function: Peak/Average Mode
 Resolution Bandwidth: 1MHz

4.2 Limit

Radiated emissions at frequencies up to 1 GHz for Class_A equipment:

Frequency range MHz	Measurement		Class_A limits dB(μV/m)
	Distance m	Detector type / bandwidth	OATS/SAC
30-230	10	Quasi Peak / 120 kHz	40
230-1000			47
30-230	3		50
230-1000			57

Radiated emissions at frequencies above 1 GHz for Class_A equipment of the EN 55032:2015+A11:2020:

Frequency range MHz	Measurement		Class_A limits dB(μV/m)
	Distance m	Detector type / bandwidth	FSOATS
1000-3000	3	Average / 1MHz	56
3000-6000			60
1000-3000		Peak / 1MHz	76
3000-6000			80

Radiated emissions at frequencies above 1 GHz for Class_A equipment of the EN 55032:2015+A11:2020:

Frequency range MHz	Measurement		Class_A limits dB(μV/m)
	Distance m	Detector type / bandwidth	FSOATS
1000-6000	3	Average / 1MHz	60
1000-6000		Peak / 1MHz	80

Note 1: The radiated emissions at frequencies above 1 GHz test limit in this report is based on EN 55032:2015+A11:2020.

Note 2: Test data in this report has been taken against the EN 55032:2015+A11:2020 limit as it is the most stringent limit. By complying with the more restrictive EN 55032:2015+A11:2020 limit compliance with the EN 55032:2015+A1:2020 limit is also demonstrated.

Radiated emissions at frequencies up to 1 GHz for Class_B equipment:

Frequency range MHz	Measurement		Class_B limits dB(μ V/m)
	Distance m	Detector type / bandwidth	OATS/SAC
30-230	10	Quasi Peak / 120 kHz	30
230-1000			37
30-230	3		40
230-1000			47

**Radiated emissions at frequencies above 1 GHz for Class_B equipment of the
EN 55032:2015+A11:2020:**

Frequency range MHz	Measurement		Class_B limits dB(μ V/m)
	Distance m	Detector type / bandwidth	FSOATS
1000-3000	3	Average / 1MHz	50
3000-6000			54
1000-3000		Peak / 1MHz	70
3000-6000			74

**Radiated emissions at frequencies above 1 GHz for Class_B equipment of the
EN 55032:2015+A1:2020:**

Frequency range MHz	Measurement		Class_B limits dB(μ V/m)
	Distance m	Detector type / bandwidth	FSOATS
1000-6000	3	Average / 1MHz	54
1000-6000		Peak / 1MHz	74

Note 1: The radiated emissions at frequencies above 1 GHz test limit in this report is based on EN 55032:2015+A11:2020.

Note 2: Test data in this report has been taken against the EN 55032:2015+A11:2020 limit as it is the most stringent limit. By complying with the more restrictive EN 55032:2015+A11:2020 limit compliance with the EN 55032:2015+A1:2020 limit is also demonstrated.

Radiated emissions from FM receivers:

Frequency range MHz	Measurement		Class_B limits dB(μ V/m)		
	Distance m	Detector type / bandwidth	Fundamental	Harmonics	
			OATS/SAC	OATS/SAC	
30-230	10	Quasi Peak / 120 kHz	50	42	
230-300				42	
300-1000				46	
30-230	3		Quasi Peak / 120 kHz	60	52
230-300					52
300-1000					56

4.3 Radiation Test Data: Configuration 1 - Radiated Emissions (Horizontal)

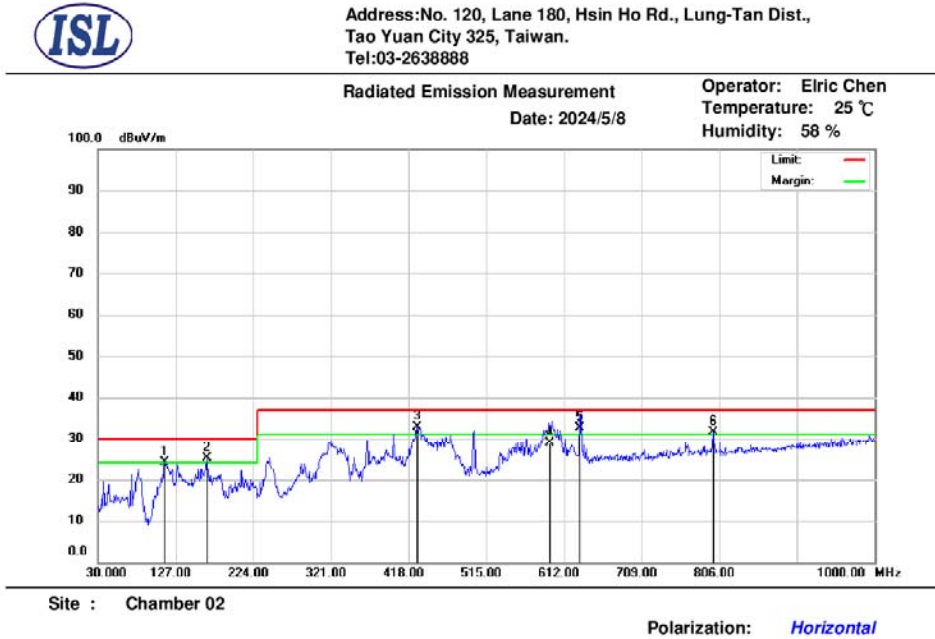

Mk.	Frequency (MHz)	RX_R (dBuV)	Correct Factor (dB/m)	Emission (dBuV/m)	Limit (dBuV/m)	Margin (dB)	Ant.Pos (cm)	Tab.Pos (deg.)	Detector
1!	113.42	42.93	-18.82	24.11	30.00	-5.89	400	12	QP
2!	165.80	40.63	-15.59	25.04	30.00	-4.96	400	47	QP
3*	428.67	42.87	-10.01	32.86	37.00	-4.14	146	360	QP
4	595.39	34.97	-6.15	28.82	37.00	-8.18	101	360	QP
5!	631.14	38.02	-5.27	32.75	37.00	-4.25	114	360	QP
6!	798.24	34.16	-2.57	31.59	37.00	-5.41	100	242	QP

* Note:

Margin = Emission – Limit

Emission = Radiated Amplitude + Correct Factor

Correct Factor = Antenna Correction Factor + Cable Loss – Pre-Amplifier Gain

A margin of -8dB means that the emission is 8dB below the limit

Antenna Distance: 10 meters

If the peak measured value meets the QP limit, The QP value is inherently compliant.



Address: No. 120, Lane 180, Hsin Ho Rd., Lung-Tan Dist.,
Tao Yuan City 325, Taiwan.
Tel: 03-2638888

Radiated Emission Measurement
Date: 2024/5/8
Operator: Ricky
Temperature: 23 °C
Humidity: 61 %

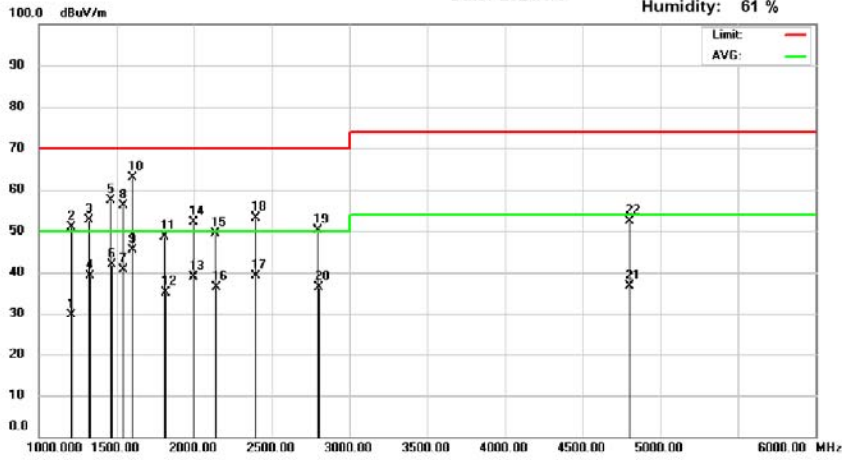

Site : Chamber 14

Polarization: Horizontal

Mk.	Frequency (MHz)	RX_R (dBuV)	Correct Factor (dB/m)	Emission (dBuV/m)	Limit (dBuV/m)	Margin (dB)	Ant.Pos (cm)	Tab.Pos (deg.)	Detector
1	1209.01	45.11	-15.36	29.75	50.00	-20.25	300	318	AVG
2	1210.00	66.19	-15.33	50.86	70.00	-19.14	300	323	peak
3	1325.00	67.35	-14.71	52.64	70.00	-17.36	200	313	peak
4	1326.67	53.72	-14.71	39.01	50.00	-10.99	200	316	AVG
5	1460.00	72.62	-15.27	57.35	70.00	-12.65	200	28	peak
6	1465.30	57.36	-15.38	41.98	50.00	-8.02	200	35	AVG
7	1539.53	57.08	-16.44	40.64	50.00	-9.36	100	344	AVG
8	1540.00	72.53	-16.44	56.09	70.00	-13.91	100	332	peak
9*	1598.60	61.28	-15.92	45.36	50.00	-4.64	100	30	AVG
10	1600.00	78.81	-15.91	62.90	70.00	-7.10	100	30	peak
11	1810.00	61.93	-13.20	48.73	70.00	-21.27	202	0	peak
12	1812.28	48.30	-13.18	35.12	50.00	-14.88	200	0	AVG
13	1990.37	50.67	-11.81	38.86	50.00	-11.14	155	357	AVG
14	1995.00	64.03	-11.80	52.23	70.00	-17.77	164	360	peak
15	2135.00	60.82	-11.41	49.41	70.00	-20.59	100	69	peak
16	2143.22	47.91	-11.44	36.47	50.00	-13.53	100	70	AVG
17	2393.78	50.36	-11.29	39.07	50.00	-10.93	100	53	AVG
18	2395.00	64.54	-11.29	53.25	70.00	-16.75	100	58	peak
19	2795.00	60.84	-10.78	50.06	70.00	-19.94	100	63	peak

* Note:

Margin = Emission – Limit

Emission = Radiated Amplitude + Correct Factor

Correct Factor = Antenna Correction Factor + Cable Loss – Pre-Amplifier Gain

A margin of -8dB means that the emission is 8dB below the limit

Antenna Distance: 3 meters

If the peak measured value meets the Average limit, The Average value is inherently compliant.

Site : Chamber 14

Polarization: *Horizontal*

Mk.	Frequency (MHz)	RX_R (dBuV)	Correct Factor(dB/m)	Emission (dBuV/m)	Limit (dBuV/m)	Margin (dB)	Ant.Pos (cm)	Tab.Pos (deg.)	Detector
20	2795.25	47.06	-10.78	36.28	50.00	-13.72	100	58	AVG
21	4795.22	45.10	-8.35	36.75	54.00	-17.25	100	67	AVG
22	4800.00	60.73	-8.36	52.37	74.00	-21.63	100	58	peak

* Note:

Margin = Emission – Limit

Emission = Radiated Amplitude + Correct Factor

Correct Factor = Antenna Correction Factor + Cable Loss – Pre-Amplifier Gain

A margin of -8dB means that the emission is 8dB below the limit

Antenna Distance: 3 meters

If the peak measured value meets the Average limit, The Average value is inherently compliant.

-Radiated Emissions (Vertical)



Address: No. 120, Lane 180, Hsin Ho Rd., Lung-Tan Dist.,
Tao Yuan City 325, Taiwan.
Tel: 03-2638888

Radiated Emission Measurement
Date: 2024/5/8

Operator: Eric Chen
Temperature: 25 °C
Humidity: 58 %

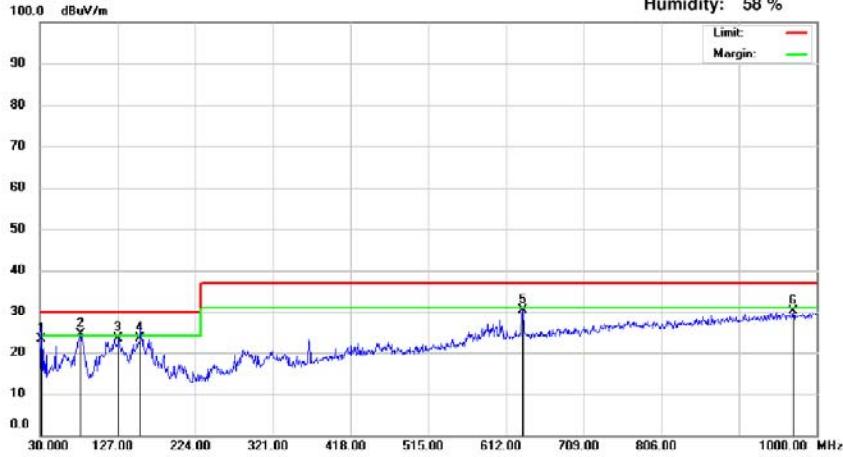

Site : Chamber 02

Polarization: Vertical

Mk.	Frequency (MHz)	RX_R (dBuV)	Correct Factor(dB/m)	Emission (dBuV/m)	Limit (dBuV/m)	Margin (dB)	Ant.Pos (cm)	Tab.Pos (deg.)	Detector
1	31.94	41.49	-18.39	23.10	30.00	-6.90	150	43	QP
2*	81.41	45.92	-21.63	24.29	30.00	-5.71	400	121	QP
3	127.97	41.24	-17.80	23.44	30.00	-6.56	100	286	QP
4	155.13	38.57	-15.27	23.30	30.00	-6.70	100	143	QP
5	633.34	35.49	-5.22	30.27	37.00	-6.73	350	360	QP
6	970.90	30.35	-0.34	30.01	37.00	-6.99	250	358	QP

* Note:

Margin = Emission – Limit

Emission = Radiated Amplitude + Correct Factor

Correct Factor = Antenna Correction Factor + Cable Loss – Pre-Amplifier Gain

A margin of -8dB means that the emission is 8dB below the limit

Antenna Distance: 10 meters

If the peak measured value meets the QP limit, The QP value is inherently compliant.



Address: No. 120, Lane 180, Hsin Ho Rd., Lung-Tan Dist.,
Tao Yuan City 325, Taiwan.
Tel: 03-2638888

Radiated Emission Measurement Operator: Ricky
Date: 2024/5/8 Temperature: 23 °C
Humidity: 61 %

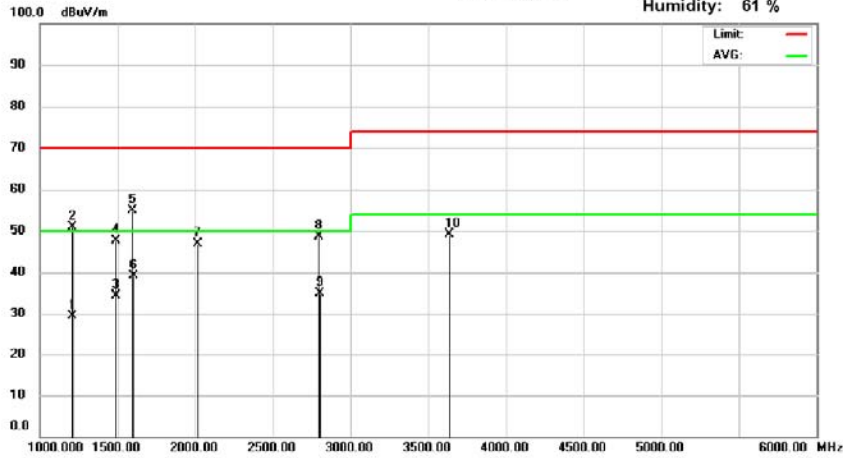

Site : Chamber 14

Polarization: Vertical

Mk.	Frequency (MHz)	RX_R (dBuV)	Correct Factor (dB/m)	Emission (dBuV/m)	Limit (dBuV/m)	Margin (dB)	Ant.Pos (cm)	Tab.Pos (deg.)	Detector
1	1206.58	44.85	-15.43	29.42	50.00	-20.58	274	0	AVG
2	1210.00	66.21	-15.33	50.88	70.00	-19.12	261	0	peak
3	1489.24	50.50	-16.05	34.45	50.00	-15.55	100	34	AVG
4	1490.00	63.76	-16.07	47.69	70.00	-22.31	100	28	peak
5	1595.00	70.90	-15.96	54.94	70.00	-15.06	100	28	peak
6*	1598.83	55.13	-15.92	39.21	50.00	-10.79	100	40	AVG
7	2015.00	58.62	-11.69	46.93	70.00	-23.07	100	98	peak
8	2795.00	59.38	-10.78	48.60	70.00	-21.40	300	76	peak
9	2795.21	45.54	-10.78	34.76	50.00	-15.24	300	80	AVG
10	3635.00	58.95	-9.74	49.21	74.00	-24.79	100	337	peak

* Note:

Margin = Emission – Limit

Emission = Radiated Amplitude + Correct Factor

Correct Factor = Antenna Correction Factor + Cable Loss – Pre-Amplifier Gain

A margin of -8dB means that the emission is 8dB below the limit

Antenna Distance: 3 meters

If the peak measured value meets the Average limit, The Average value is inherently compliant.

4.4 Test Setup Photo

Front View (30MHz~1GHz)



Back View (30MHz~1GHz)

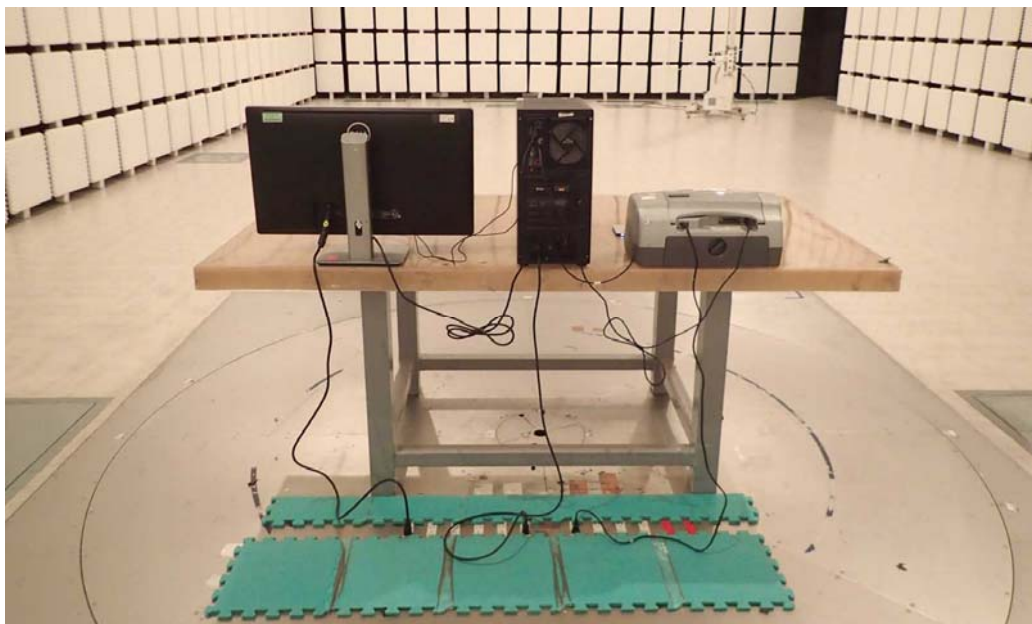

Front View (above 1GHz)

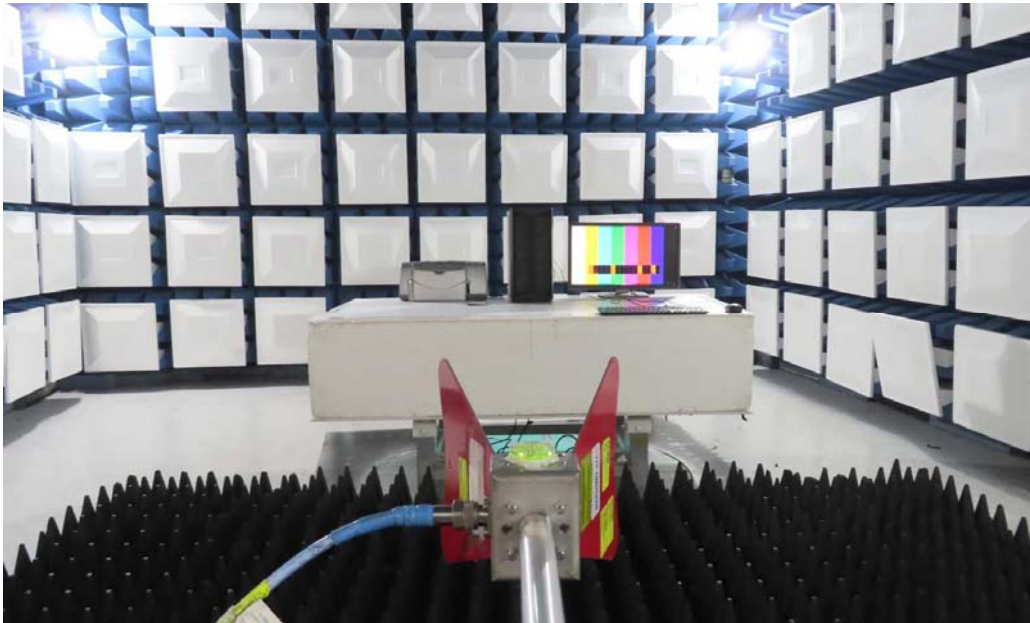

Back View (above 1GHz)

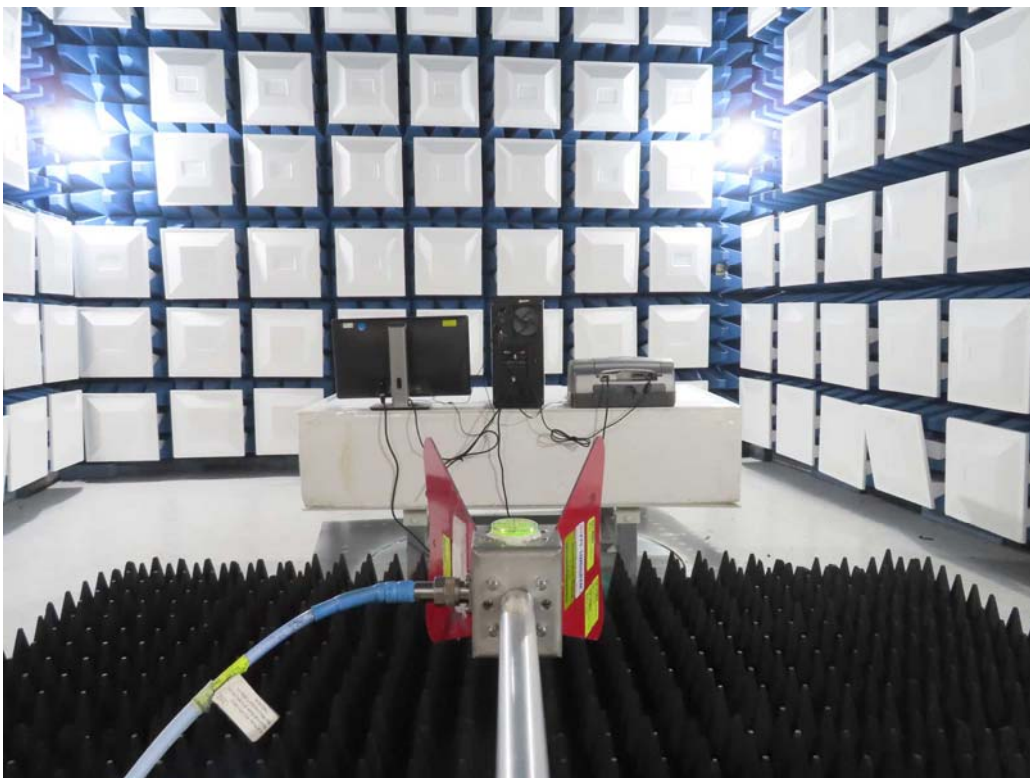

5. Voltage Disturbance Emissions at Antenna Terminals

5.1 Test Setup and Procedure

5.1.1 Test Setup

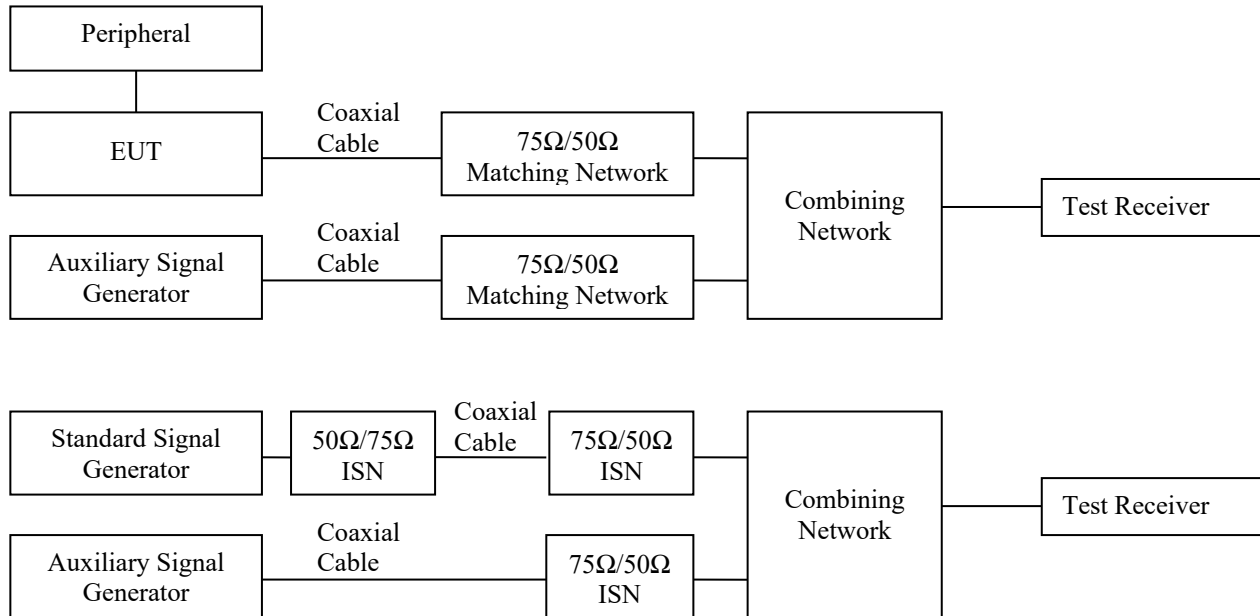

5.1.2 Test Procedure

The output level of the auxiliary signal generator was set to 70dB μ V at the EUT antenna terminal with 75 ohms impedance with an un-modulated carrier.

The highest emissions were analyzed in details by operating the spectrum analyzer and/or EMI receiver in quasi-peak mode to determine the precise amplitude of the emissions. The power of EUT was switched off to make sure the emission was not contributed by the auxiliary signal generator. While doing so, the interconnecting cables and major parts of the system were moved around to maximize the emission.

5.1.3 EMI Receiver Configuration (for the frequencies tested)

Frequency Range:	30MHz-2150MHz
Detector Function:	Quasi-Peak Mode
Resolution Bandwidth:	120kHz

5.1.4 Limit

Applicable to:

1. TV broadcast receiver tuner ports with an accessible connector.
2. RF modulator output ports.
3. FM broadcast receiver tuner ports with an accessible connector.

Applicable to						
1. TV broadcast receiver tuner ports (3.1.8) with an accessible connector						
2. RF modulator output ports (3.1.29)						
3. FM broadcast receiver tuner ports (3.1.8) with an accessible connector						
Table clause	Frequency range MHz	Detector type/ bandwidth	Class B limits dB(μV) 75 Ω			Applicability
			Other	Local Oscillator Fundamental	Local Oscillator Harmonics	
A13.1	30 to 950	For frequencies ≤1 GHz	46	46	46	See ^a
	950 to 2 150		46	54	54	
A13.2	950 to 2 150	Quasi Peak/ 120 kHz	46	54	54	See ^b
A13.3	30 to 300		46	54	50	See ^c
	300 to 1 000		52			
A13.4	30 to 300	For frequencies ≥1 GHz	46	66	59	See ^d
	300 to 1 000				52	
A13.5	30 to 950	Peak/ 1 MHz	46	76	46	See ^e
	950 to 2 150			n/a	54	

^a Television receivers (analogue or digital), video recorders and PC TV broadcast receiver tuner cards working in channels between 30 MHz and 1 GHz, and digital audio receivers.

^b Tuner units (not the LNB) for satellite signal reception.

^c Frequency modulation audio receivers and PC tuner cards.

^d Frequency modulation car radios.

^e Applicable to EUTs with RF modulator output ports (for example DVD equipment, video recorders, camcorders and decoders etc.) designed to connect to TV broadcast receiver tuner ports. Limits specified for the LO are for the RF modulator carrier signal and harmonics.

The term 'other' refers to all emissions other than the fundamental and the harmonics of the LO.

The measurement shall cover the entire frequency range.

The EUT shall be tuned in accordance with Table B.3 and clause C.4.2.1.

****Remarks: It is not necessary to be tested on this item.**

6. Differential Voltage Emissions

6.1 Test Setup and Procedure

6.1.1 Test Setup

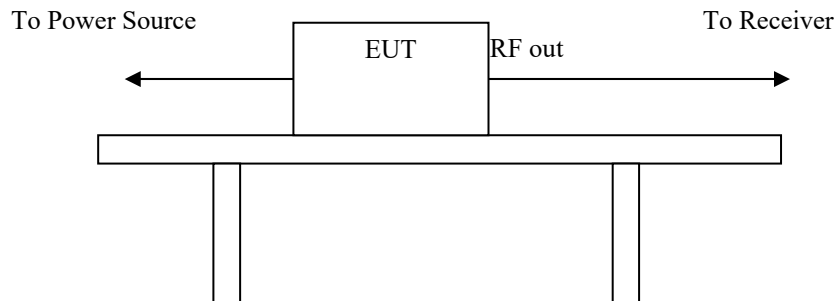

6.1.2 Test Procedure

The output level of the auxiliary signal generator was set to 70dB μ V at the EUT antenna terminal with 75 ohms impedance with an un-modulated carrier.

The highest emissions were analyzed in details by operating the spectrum analyzer and/or EMI receiver in quasi-peak mode to determine the precise amplitude of the emissions. The power of EUT was switched off to make sure the emission was not contributed by the auxiliary signal generator. While doing so, the interconnecting cables and major parts of the system were moved around to maximize the emission.

6.1.3 EMI Receiver Configuration (for the frequencies tested)

Frequency Range:	30MHz-2150MHz
Detector Function:	Quasi-Peak Mode
Resolution Bandwidth:	120kHz

6.1.4 Limit

Applicable to:

1. TV broadcast receiver tuner ports with an accessible connector.
2. RF modulator output ports.
3. FM broadcast receiver tuner ports with an accessible connector.

Applicable to						
1. TV broadcast receiver tuner ports (3.1.8) with an accessible connector						
2. RF modulator output ports (3.1.29)						
3. FM broadcast receiver tuner ports (3.1.8) with an accessible connector						
Table clause	Frequency range MHz	Detector type/ bandwidth	Class B limits dB(μV) 75 Ω			Applicability
			Other	Local Oscillator Fundamental	Local Oscillator Harmonics	
A13.1	30 to 950	For frequencies ≤1 GHz	46	46	46	See ^a
	950 to 2 150		46	54	54	
A13.2	950 to 2 150	Quasi Peak/ 120 kHz	46	54	54	See ^b
A13.3	30 to 300		For frequencies ≥1 GHz	46	66	50
	300 to 1 000	52				
A13.4	30 to 300	Peak/ 1 MHz	46	76	59	See ^d
	300 to 1 000				52	
A13.5	30 to 950	Peak/ 1 MHz	46	n/a	46	See ^e
	950 to 2 150				54	

^a Television receivers (analogue or digital), video recorders and PC TV broadcast receiver tuner cards working in channels between 30 MHz and 1 GHz, and digital audio receivers.

^b Tuner units (not the LNB) for satellite signal reception.

^c Frequency modulation audio receivers and PC tuner cards.

^d Frequency modulation car radios.

^e Applicable to EUTs with RF modulator output ports (for example DVD equipment, video recorders, camcorders and decoders etc.) designed to connect to TV broadcast receiver tuner ports. Limits specified for the LO are for the RF modulator carrier signal and harmonics.

The term 'other' refers to all emissions other than the fundamental and the harmonics of the LO.

The measurement shall cover the entire frequency range.

The EUT shall be tuned in accordance with Table B.3 and clause C.4.2.1.

****Remarks: It is not necessary to be tested on this item.**

7. Outdoor units of home satellite receiving systems

7.1 Test Setup and Procedure

7.1.1 Test Setup

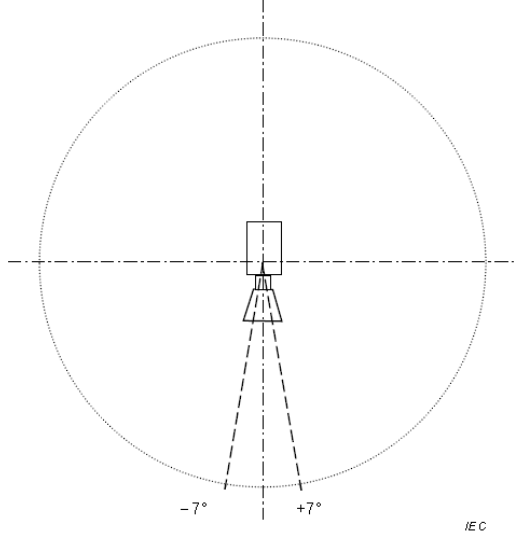
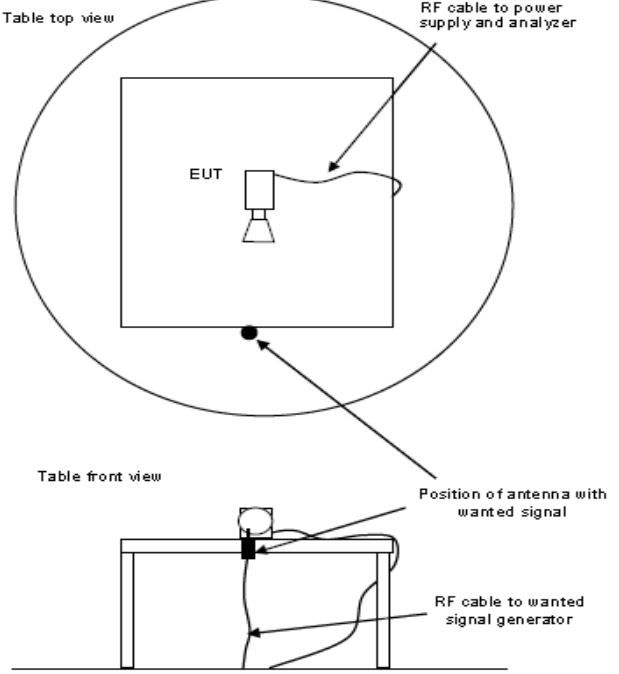
	
Description of $\pm 7^\circ$ of the main beam axis of the EUT	Measurement arrangements of transmit antenna for the wanted signal

7.1.2 Test Procedure

The input signal shall be adjusted to get the maximum rated output level from the EUT. For the measurement in the frequency range from 30 MHz to 18 GHz the input signal shall be adjusted so that the output frequency is within this frequency range. For the measurement in the frequency range above 1 GHz, the frequency of the input signal shall be adjusted in such a way that the EUT is measured, as a minimum, at the lowest, middle and highest rated output frequency within the measured frequency range.

7.1.3 Spectrum Analyzer Configuration (for the frequencies tested)

Frequency Range: 30MHz--1000MHz
 Detector Function: Quasi-Peak Mode
 Resolution Bandwidth: 120kHz

Frequency Range: Above 1000MHz
 Detector Function: Peak/Average Mode
 Resolution Bandwidth: 1MHz

7.1.4 Limit

EN 55032:2015+A11:2020

Table Clause	Frequency Range MHz	Measurement			Class B Limits	Applicable to
		Facility (see Table A.1)	Distance m	Detector type / Bandwidth		
A7.1	30 to 1 000	SAC / OATS / FAR	See Table A.4	Quasi Peak / 120 kHz	See Table A.4	
A7.2	1 000 to 2 500	FSOATS	3	Average / 1 MHz	50 dB(μV/m)	LO leakage and spurious radiated emissions from the EUT, in the region outside ±7° of the main beam axis. See Figure H.1
	2 500 to 18 000				64 dB(μV/m)	
A7.3	1 000 to 18 000	FSOATS	3	Average / 1 MHz	37 dB(μV/m)	LO leakage from the EUT, in the region within ±7° of the main beam axis. See Figure H.1
A7.4	1 000 to 18 000	Conducted (Clause H.4)	n/a	Average / 1 MHz	30 dBpW	

For details of the EUT configuration, see Annex H.

For radiated emissions measurements at frequencies up to 1 GHz, the requirements defined in Table A.4 shall be satisfied.

Apply the appropriate limits across the entire frequency range.

Apply the limits defined in table Clause A7.1 and A7.2. Also apply the limits defined in either table Clause A7.3 or A7.4.

EN 55032:2015+A1:2020

Table Clause	Frequency Range MHz	Measurement			Class B Limits	Notes
		Facility (see Table A.1)	Distance m	Detector type / Bandwidth		
A7.1	30 to 1 000	SAC / OATS / FAR	See Table A.4	Quasi Peak / 120 kHz	See Table A.4	See Annex H
A7.2	1 000 to 2 500	FSOATS	3	Average / 1 MHz	50 dB(μV/m)	LO leakage and spurious radiated emissions from the EUT, in the region outside ±7° azimuth of the main beam axis. See Annex H
	2 500 to 18 000				64 dB(μV/m)	
A7.3	1 000 to 18 000	FSOATS	3	Average / 1 MHz	70 dB(μV/m)	LO leakage from the EUT, in the region within ±7° azimuth of the main beam axis. See Annex H
A7.4	1 000 to 18 000	Conducted (Clause H.4)	n/a	Average / 1 MHz	63 dBpW	

Apply the limits defined in table Clause A7.1 and A7.2. Also apply the limits defined in either table Clause A7.3 or A7.4.

For details of the EUT configuration, see Annex H.

For radiated emissions measurements at frequencies up to 1 GHz, the requirements defined in Table A.4 shall be satisfied.

Apply the appropriate limits across the entire frequency range.

Note 1: The test limit in this report is based on EN 55032:2015+A11:2020.

Note 2: Test data in this report has been taken against the EN 55032:2015+A11:2020 limit as it is the most stringent limit. By complying with the more restrictive EN 55032:2015+A11:2020 limit compliance with the EN 55032:2015+A1:2020 limit is also demonstrated.

****Remarks: It is not necessary to be tested on this item.**

8. Electrostatic discharge immunity

8.1 Test Specification and Setup

8.1.1 Test Specification

Port:	Enclosure
Basic Standard:	EN 61000-4-2 / IEC 61000-4-2 / BS EN 61000-4-2 (details referred to Sec 1.2)
Test Level:	Air +/- 2 kV, +/- 4 kV, +/- 8 kV Contact +/- 4 kV
Criteria:	B
Test Procedure:	refer to ISL SOP-EN 61000-4-2 TEST SOP
Temperature:	See attached data
Humidity:	See attached data

Selected Test Point

Air: discharges were applied to slots, aperture or insulating surfaces. 10 single air discharges were applied to each selected points.

Contact: 10 discharges minimum were to the selected contact points.

Indirect Contact Points: 10 discharges were applied to center of one edge of VCP and each EUT side of HCP with 10 cm away from EUT.

8.1.2 Test Setup

EUT is 1m from the wall and other metallic structure. When Battery test mode is needed, a cable with one 470kΩ resistor at two rare ends is connected from metallic part of EUT and screwed to HCP.

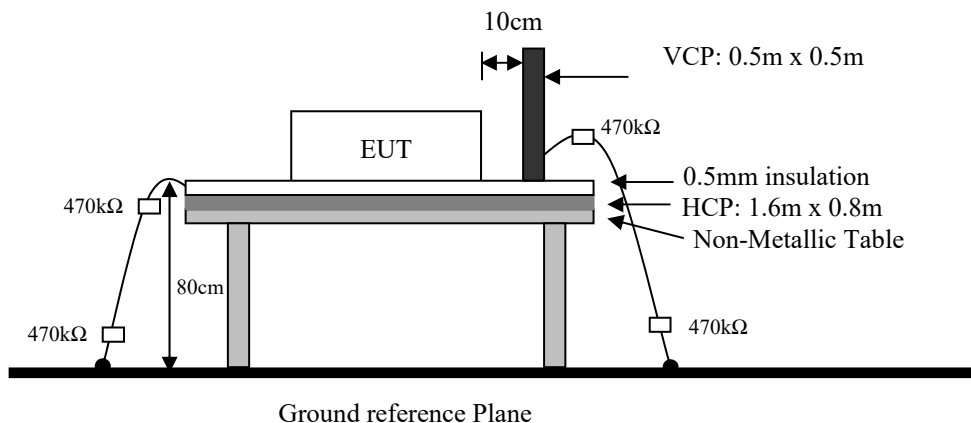

8.1.3 Test Result

Performance of EUT complies with the given specification.

8.2 Test Point

Red arrow lines indicate the contact points, and blue arrow lines indicate the air points.

Figure 1: Test Point Assignments Discharge:

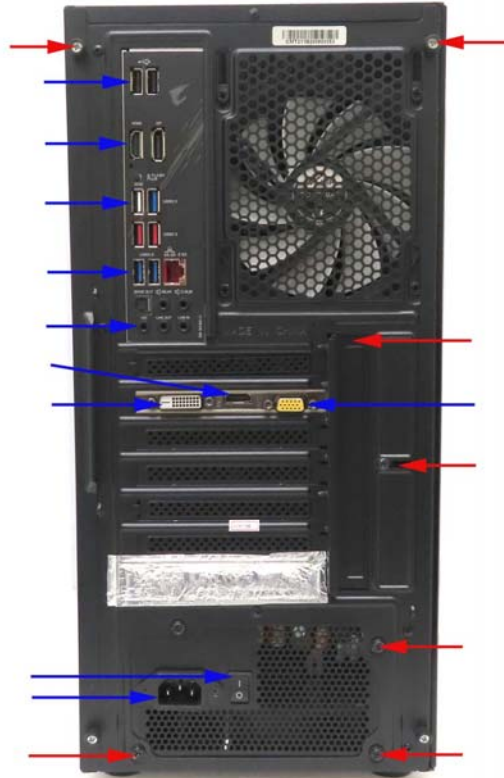

8.3 Test Setup Photo



9. Radiated, radio-frequency, electromagnetic field immunity

9.1 Test Specification and Setup

9.1.1 Test Specification

Port:	Enclosure
Basic Standard:	EN IEC 61000-4-3 / IEC 61000-4-3 / BS EN IEC 61000-4-3 (details referred to Sec 1.2)
Test Level:	3 V/m
Modulation:	AM 1kHz 80%
Frequency range:	80 MHz~1 GHz 1800MHz, 2600MHz, 3500MHz, 5000MHz
Frequency Step:	1% of last step frequency
Dwell time:	2s
Polarization:	Vertical and Horizontal
EUT Azimuth Angle	☒0° ☒90° ☒180° ☒270°
Criteria:	A
Test Procedure:	refer to ISL SOP-EN 61000-4-3 TEST SOP
Temperature:	See attached data
Humidity:	See attached data

9.1.2 Test Setup

The field sensor is placed at one calibration grid point to check the intensity of the established fields on both polarizations. EUT is adjusted to have each side of EUT face coincident with the calibration plane. A CCD camera and speakers are used to monitor the condition of EUT for the performance judgment.

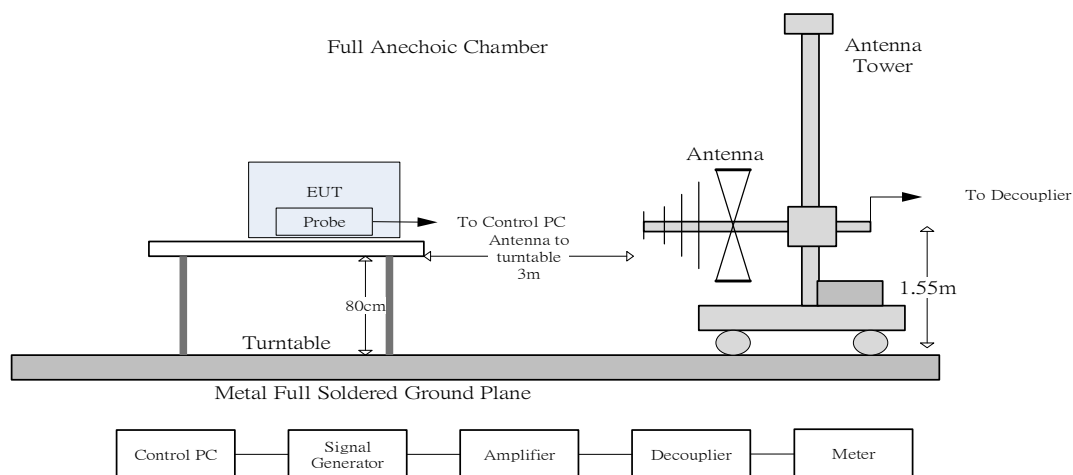

9.1.3 Test Result

Performance of EUT complies with the given specification.

9.2 Test Setup Photo

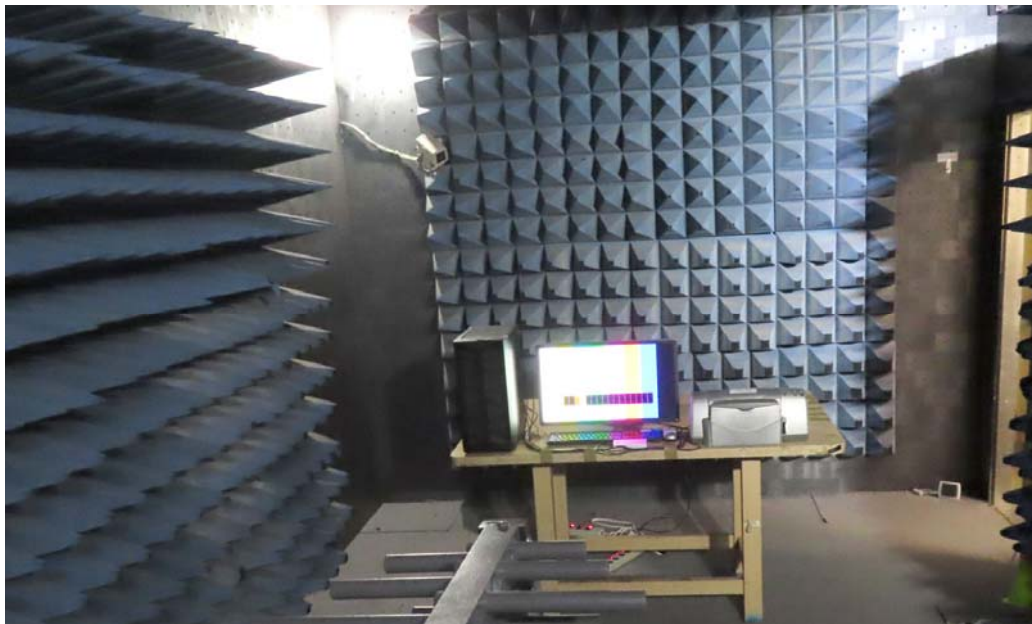

10. Electrical fast transient/burst immunity

10.1 Test Specification and Setup

10.1.1 Test Specification

Port:	AC mains
Basic Standard:	EN 61000-4-4 / IEC 61000-4-4 / BS EN 61000-4-4 (details referred to Sec 1.2)
Test Level:	AC Power Port: +/- 1 kV
Rise Time:	5ns
Hold Time:	50ns
Burst Period:	300ms
Repetition Frequency:	5kHz
Criteria:	B
Test Procedure:	refer to ISL SOP-EN 61000-4-4 TEST SOP
Temperature:	See attached data
Humidity:	See attached data

Test Procedure

Test Procedure

The EUT was setup on a nonconductive table 0.1 m above a reference ground plane.

Test Points	Polarity	Result	Comment
Line	+	N	60 sec
	-	N	60 sec
Neutral	+	N	60 sec
	-	N	60 sec
Ground	+	N	60 sec
	-	N	60 sec
Line and Neutral	+	N	60 sec
	-	N	60 sec
Line and Ground	+	N	60 sec
	-	N	60 sec
Neutral and Ground	+	N	60 sec
	-	N	60 sec
Line and Neutral and Ground	+	N	60 sec
	-	N	60 sec

Note: 'N' means normal, the EUT function is correct during the test.

10.1.2 Test Setup

EUT is at least 50cm from the conductive structure.

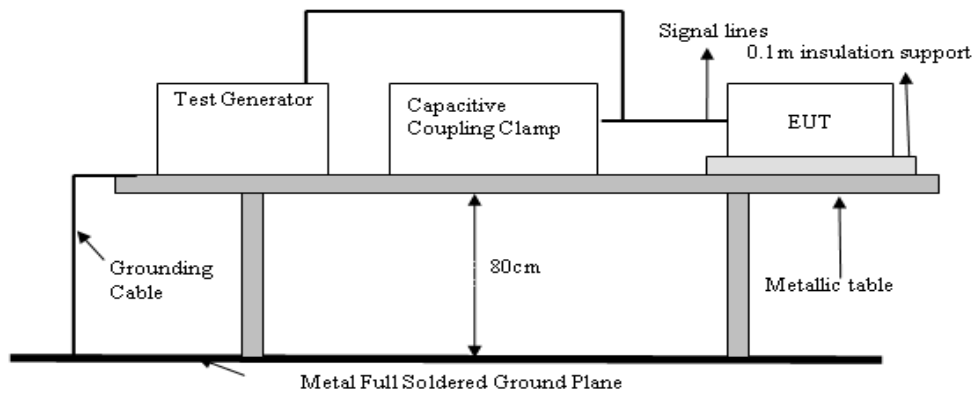
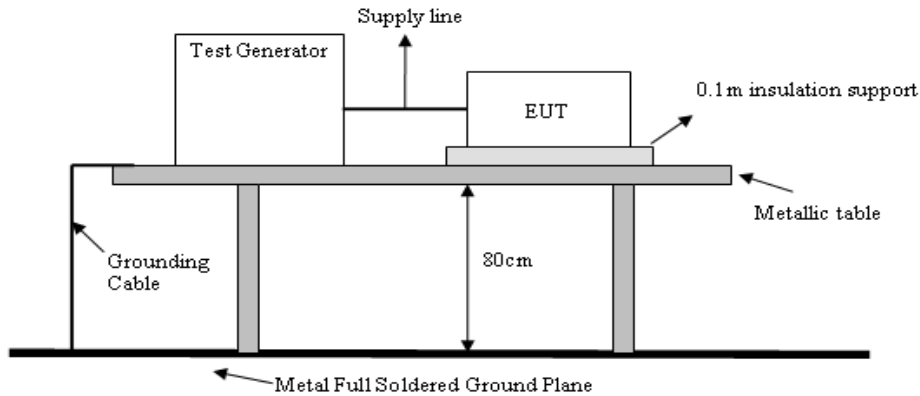

10.1.3 Test Result

Performance of EUT complies with the given specification.

10.2 Test Setup Photo



11. Surge immunity

11.1 Test Specification and Setup

11.1.1 Test Specification

Port:	AC mains
Basic Standard:	EN 61000-4-5 / IEC 61000-4-5 / BS EN 61000-4-5 (details referred to Sec 1.2)
Test Level:	Line to Line: +/- 0.5 kV, +/- 1 kV Line to Earth: +/- 0.5 kV, +/- 1 kV, +/- 2kV
Rise Time:	1.2us
Hold Time:	50us
Repetition Rate:	30 seconds
Angle:	<input type="checkbox"/> 0° <input checked="" type="checkbox"/> 90° <input type="checkbox"/> 180° <input checked="" type="checkbox"/> 270°
Criteria:	B
Test Procedure:	refer to ISL QA -T4-E-S10
Temperature:	See attached data
Humidity:	See attached data

11.1.2 Test Setup

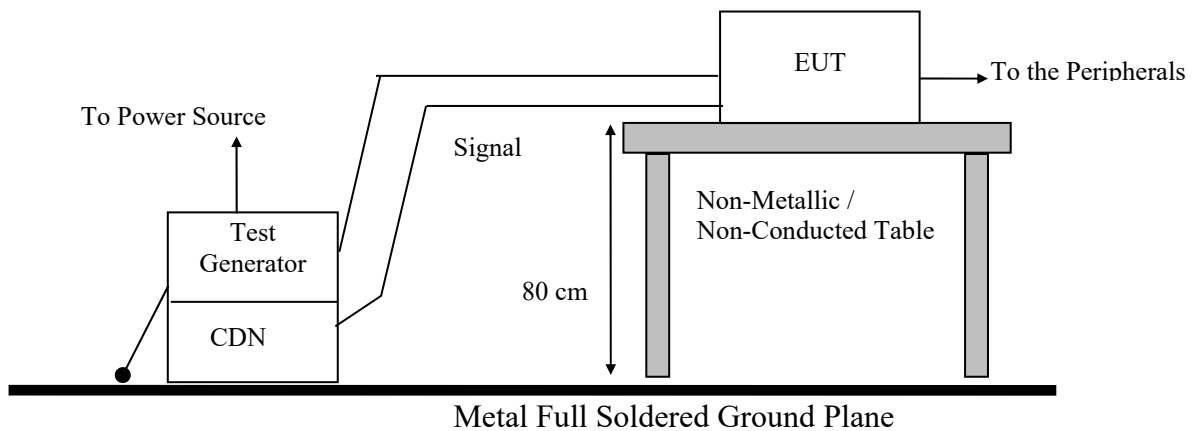

11.1.3 Test Result

Performance of EUT complies with the given specification.

11.2 Test Setup Photo



12. Immunity to conducted disturbances

12.1 Test Specification and Setup

12.1.1 Test Specification

Port:	AC mains
Basic Standard:	EN 61000-4-6 / IEC 61000-4-6 / BS EN 61000-4-6 (details referred to Sec 1.2)
Frequency range and Test Level:	0.15MHz to 10MHz: 3 Vrms 10MHz to 30MHz: 3Vrms to 1Vrms 30MHz to 80MHz: 1Vrms
Modulation:	AM 1kHz 80%
Frequency Step:	1% of last Frequency
Dwell time:	2s
Criteria:	A
CDN Type:	CDN M2+M3
Test Procedure:	refer to ISL QA -T4-E-S11
Temperature:	See attached data
Humidity:	See attached data

12.1.2 Test Setup

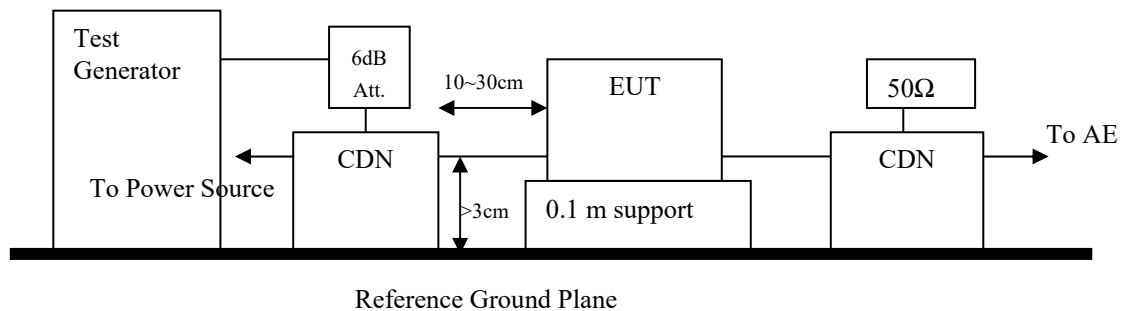

12.1.3 Test Result

Performance of EUT complies with the given specification.

12.2 Test Setup Photo



13. Power frequency magnetic field immunity

13.1 Test Specification and Setup

13.1.1 Test Specification

Port:	Enclosure
Basic Standard:	EN 61000-4-8 / IEC 61000-4-8 / BS EN 61000-4-8 (details referred to Sec 1.2)
Test Level:	1A/m
Polarization:	X, Y, Z
Criteria:	A
Test Procedure:	refer to ISL QA -T4-E-S12
Temperature:	See attached data
Humidity:	See attached data

13.1.2 Test Setup

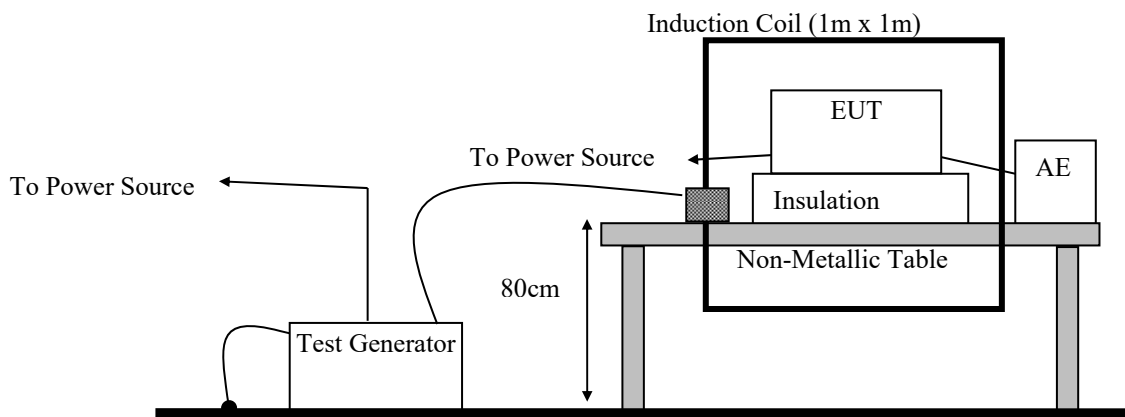

13.1.3 Test Result

Performance of EUT complies with the given specification.

13.2 Test Setup Photo



14. Voltage dips, short interruptions and voltage variations immunity

14.1 Test Specification and Setup

14.1.1 Test Specification

Port:	AC mains
Basic Standard:	EN IEC 61000-4-11 / IEC 61000-4-11 / BS EN IEC 61000-4-11 (details referred to Sec 1.2)
When the product is greater than 16A does not apply to this Standard, it is not necessary to be tested on this item. In addition, IEC/EN 61000-4-34 Standard was used to evaluating.	
Test Level: Criteria:	>95% in 0.5 cycle B
Test Level: Criteria:	30% in 25 cycle C
Test Level: Criteria:	>95% in 250 cycle C
Phase:	0°; 180°
Test intervals:	3 times with 10s each
Test Procedure:	refer to ISL SOP-EN 61000-4-11 TEST SOP
Temperature:	See attached data
Humidity:	See attached data

14.1.2 Test Setup

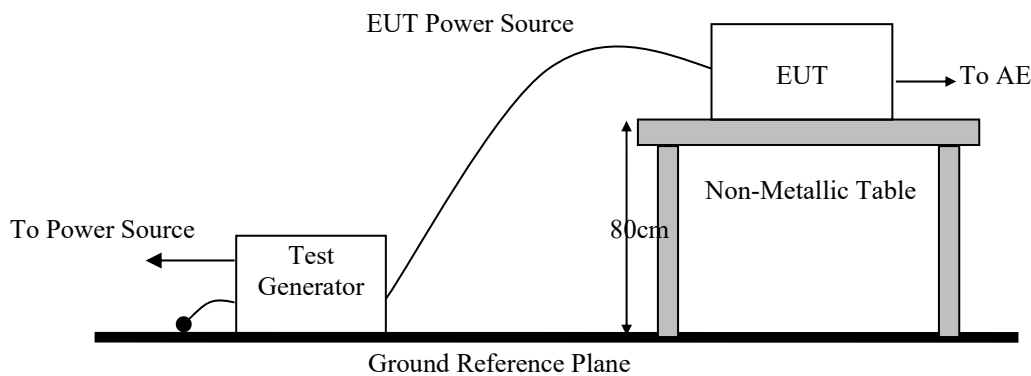

14.1.3 Test Result

Performance of EUT complies with the given specification.

14.2 Test Setup Photo



15. Harmonics

15.1 Test Specification and Setup

15.1.1 Test Specification

Port:	AC mains
Active Input Power:	<75W
Basic Standard:	EN IEC 61000-3-2 / IEC 61000-3-2 / BS EN IEC 61000-3-2 (details referred to Sec 1.2)
Test Duration:	2.5min
Class:	A
Test Procedure:	refer to ISL SOP-HARMONIC AND FLICKER TEST SOP
Temperature:	23°C
Humidity:	56%

Test Procedure

The EUT is supplied in series with shunts or current transformers from a source having the same nominal voltage and frequency as the rated supply voltage and frequency of the EUT. The EUT is configured to its rated current with additional resistive load when the testing is performed.

Equipment having more than one rated voltage shall be tested at the rated voltage producing the highest harmonics as compared with the limits.

15.1.2 Test Setup

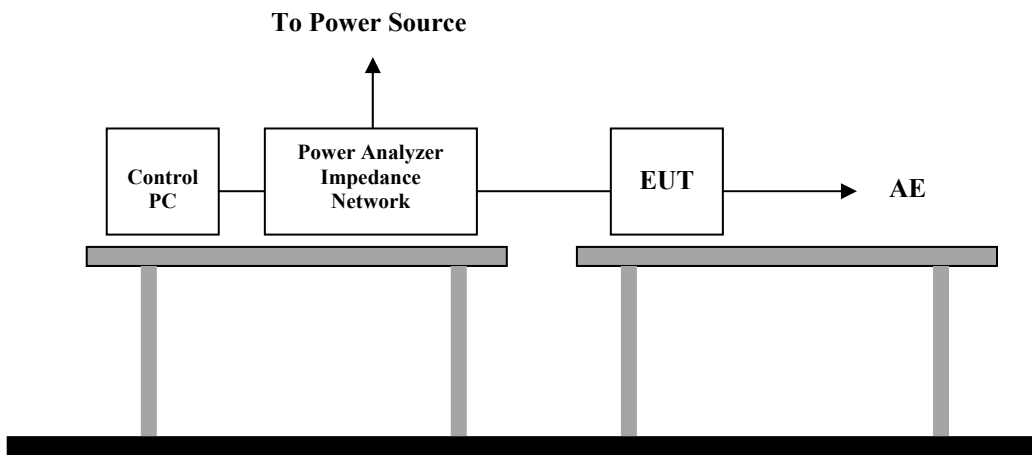

15.1.3 Limit

Limits of Class A Harmonics Currents

Harmonics Order n	Maximum Permissible harmonic current A	Harmonics Order n	Maximum Permissible harmonic current A
Odd harmonics		Even harmonics	
3	2.30	2	1.08
5	1.14	4	0.43
7	0.77	6	0.30
9	0.40	8 ≤ n ≤ 40	0.23 * 8/n
11	0.33		
13	0.21		
15 ≤ n ≤ 39	0.15 * 15/n		

15.1.4 Test Result

Active input power under 75W, no limit apply, declare compliance

16. Voltage fluctuations and flicker

16.1 Test Specification and Setup

16.1.1 Test Specification

Port:	AC mains
Basic Standard:	EN 61000-3-3 / IEC 61000-3-3 / BS EN 61000-3-3 (details referred to Sec 1.2)
Test Procedure:	refer to ISL SOP-HARMONIC AND FLICKER TEST SOP
Observation period:	For Pst 10min For Plt 2 hours
Temperature:	23°C
Humidity:	56%

Test Procedure

The EUT is supplied in series with reference impedance from a power source with the voltage and frequency as the nominal supply voltage and frequency of the EUT.

16.1.2 Test Setup

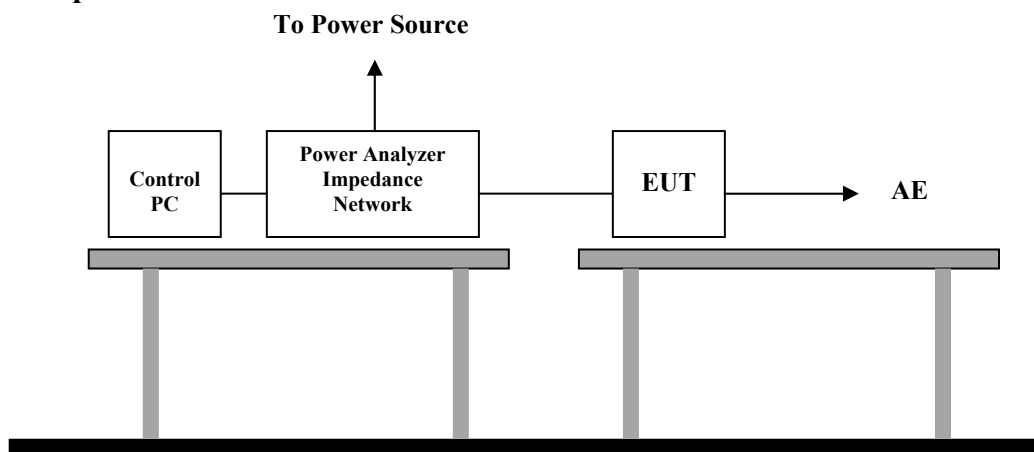

16.1.3 Test Result

Performance of EUT complies with the given specification.

16.2 Test Data

Test File: F-20240515_801
Test Class: Flicker Test, All Parameters (Ext Ref. Imped.) (1PH-FMR3)
Test Result: PASS
Test Duration (min): 10

Last Test Parameters:

Phase A

Vrms (Volts):	229.54	Frequency (Hz):	50.00
I_{rms} (Amps):	0.297	Power (W):	51.16
V-THD (%):	0.401	T-Max (ms):	0 (500)
dmax (%):	0.000 (4.000)	Hi dmax (%):	0.000 (4.000)
dc (%):	0.000 (3.300)	Hi dc (%):	0.000 (3.300)
Pst-001 :	0.074 (1.000)		

Pst Spectrum



16.3 Test Setup Photo



16.4 Appendix

16.5 Appendix A: Test Equipment

16.5.1 Test Equipment List

Location	Equipment Name	Brand	Model	S/N	Last Cal. Date	Next Cal. Date
Conduction 03	EMI Receiver 13	R&S	ESCI	101015	05/30/2023	05/30/2024
Conduction 03	Chamber05-1 Cable	WOKEN	CFD 300-NL	Chamber05-1 Cable	08/25/2023	08/25/2024
Conduction 03	LISN 19	R&S	ENV216	101425	11/23/2023	11/23/2024
Conduction 03	LISN 22	ROHDE & SCHWARZ	ENV216	101478	11/01/2023	11/01/2024

Location Chamber02	Equipment Name	Brand	Model	S/N	Last Cal. Date	Next Cal. Date
Radiation	BILOG Antenna 17 (30MHz~1GHz)	SCHWARZBECK	VULB 9168+EMCI-N-6-05	645	11/16/2023	11/16/2024
Radiation	Preamplifier 25	EMCI	EMC9135	980295	03/12/2024	03/12/2025
Radiation	Coaxial Cable Chmb 02-10M-02	EMC	RG214U	Chmb 02-10M-02	10/04/2023	10/04/2024
Radiation	EMI Receiver 14	R&S	ESCI	101034	05/09/2024	05/09/2025

Location Chmb14	Equipment Name	Brand	Model	S/N	Last Cal. Date	Next Cal. Date
Rad. Above 1GHz	Spectrum Analyzer 25	R&S	FSV 40	101499	10/24/2023	10/24/2024
Rad. Above 1GHz	Horn Antenna 06	ETS-Lindgren	3117	00066665	12/15/2023	12/15/2024
Rad. Above 1GHz	Preamplifier 20	EMCI	EMC051845	980084	11/22/2023	11/22/2024
Rad. Above 1GHz	Microwave Cable-41	woken	WCBA-WCA04NM.SM5	1-18G	03/01/2024	03/01/2025
Rad. Above 1GHz	Microwave Cable 26	EMCI	EMC104-NM-SM-800	141112	03/01/2024	03/01/2025

Location	Equipment Name	Brand	Model	S/N	Last Cal. Date	Next Cal. Date
EN61K-4-2	ESD Gun 12	EM TEST	Dito	P1650188689	03/26/2024	03/26/2025
EN61K-4-3	Broadband Log-Periodic Antenna	AR	AT1080	310698	N/A	N/A
EN61K-4-3	Horn Antenna RF-01	AR	ATS700M11G	0335864	N/A	N/A
EN61K-4-3	Amplifier 80Mz~1GHz 250W	AR	250W1000C	358877	N/A	N/A
EN61K-4-3	Amplifier 0.7~6GHz 60W	AR	60S1G6	358973	N/A	N/A
EN61K-4-3	Broadband Coupler 80M~1GHz	Amplifier Research	DC6180A	0341805	N/A	N/A
EN61K-4-3	Coaxial Cable	INSULATED	NPS-4806-2360-NP3	108599.003.01.03	N/A	N/A
EN61K-4-3	Broadband Coupler 1-6GHz	Woken	STI07-0005-40	N/A	N/A	N/A
EN61K-4-3	Signal Generator 07	R&S	SMB100A	107780	12/26/2023	12/26/2024
EN61K-4-4	Signal Generator 10	EMC Partner	IMU3000	1547	09/07/2023	09/07/2024
EN61K-4-5	CDN-UTP8 03	EMC-PARTNER	CDN-UPT8ESD3	1546	03/14/2024	03/14/2025
EN61K-4-5	Surge Tester	EMC Partner	MIG0603IN3	523	07/11/2023	07/11/2024
EN61K-4-6	CDN M2+M3 05	FRANKONIA	CDN M2+M3	A2210235/2013	03/19/2024	03/19/2025
EN61K-4-6	Coaxial Cable 4-6 02-1			4-6 02-1	N/A	N/A
EN61K-4-6	Conducted Immunity Test System 02	Frankonia	CIT-10-75-DC	126B1301/2014	03/15/2024	03/15/2025
EN61K-4-8	Magnetic Field Immunity Loop	FCC	F-1000-4-8-L-1M	01037	04/11/2024	04/11/2025
EN61K-4-8	Magnetic Field Test Generator	FCC	F-1000-4-8-G-12 5A	01038	04/11/2024	04/11/2025
EN61K-4-11	Voltage Dip and UP Simulator 01	NoiseKen	VDS-2002	VDS1750439	09/05/2023	09/05/2024
EN61K-3-2/3, EN61K-3-11-12	Harmonics & Flickers Test System 04	PACIFIC*APS	ECTS2-3450F-n	550072	01/18/2024	01/18/2025

PS: N/A => The equipment does not need calibration.

****Software for Controlling Spectrum/Receiver and Calculating Test Data**

Test Item	Filename	Version
EN IEC 61000-3-2	HFa-16 Program	v1.0.27.0
EN 61000-3-3	HFa-16 Program	v1.0.27.0
EN 61000-4-2	N/A	2.0
EN IEC 61000-4-3	i2	529b
EN 61000-4-4	TEM A3000	v4.6.1
EN 61000-4-5	EMC Partner	1.69
EN 61000-4-6	i2	529b
EN 61000-4-8	N/A	
EN IEC 61000-4-11 (<16A)	NOISE KEN	2.0

Site	Filename	Version
Conduction/Radiation	EZ EMC	ISL-03A2

16.6 Appendix B: Uncertainty of Measurement

The laboratory measurement uncertainty accordance with refers to CISPR 16-4-2. If U_{lab} is less than or equal to U_{cispr} in Table 1, then the test report may either state the value of U_{lab} or state that U_{lab} is less than U_{cispr}.

The coverage factor k = 2 yields approximately a 95 % level of confidence.

<Conduction 03>

AMN: ± 2.9 dB

<Chamber 02 (10m)>

Horizontal

30MHz~200MHz: ± 4.5 dB

200MHz~1000MHz: ± 4.3 dB

Vertical

30MHz~200MHz: ± 4.9 dB

200MHz~1000MHz: ± 4.7 dB

<Chamber 14 (3m)>

1GHz~6GHz: ± 5.1 dB

<Immunity 02>

Test item	Uncertainty	Test item	Uncertainty
EN 61000-4-2 (ESD)		EN 61000-4-6 (CS)	
Rise time tr	≤ 11%	CDN	1.9 dB
Peak current I _p	≤ 5.9%	EM Clamp	3.4 dB
current at 30 ns	≤ 6.0%	EN 61000-4-8 (Magnetic)	5.6 %
current at 60 ns	≤ 5.9%	EN IEC 61000-4-11 (Dips)	0.57 %
EN IEC 61000-4-3 (RS)	2.7 dB	EN IEC 61000-3-2 (Harmonics)	1.2 %
EN 61000-4-4 (EFT)		EN 61000-3-3 (Fluctuations and Flicker)	8.1 %
voltage rise time (tr)	7.2 %		
peak voltage value (VP)	6.3 %		
voltage pulse width (t _w)	5.1 %		
EN 61000-4-5 (Surge)			
open-circuit voltage front time	12 %		
open-circuit voltage peak value	8.7 %		
open-circuit voltage duration (T _d)	0.55%		

16.7 Appendix C: Photographs of EUT

Please refer to the File of **ISL-24LE0335P-R1-MA**

--- END ---