

FCC/ISED EMC Test Report

Report No. : BTL-FCCE-1-2311T006
Equipment : Micro SD Card
Model Name : Industrial Micro SD R1-M, Industrial Micro SDHC R1-M,
Industrial Micro SDXC R1-M, Industrial Micro SD R1-SL,
Industrial Micro SDHC R1-SL, Industrial Micro SDXC R1-SL,
Industrial Micro SDHC MSD-WORM, Industrial Micro SDXC MSD-WORM
Brand Name : Apacer
Applicant : Apacer Technology Inc.
Address : 1F., No.32, Zhongcheng Rd., Tucheng Dist., New Taipei City 236, Taiwan
R.O.C.
FCC Rule Part(s) : FCC CFR Title 47, Part 15, Subpart B Class B
ISED Standard(s) : ICES-003, Issue 7, October 15, 2020 Class B
Measurement : ANSI C63.4-2014
Procedure(s) : ANSI C63.4a-2017
Date of Receipt : 2023/11/6
Date of Test : 2023/11/8 ~ 2023/11/14
Issued Date : 2023/11/20

The above equipment has been tested and found in compliance with the requirement of the above standards by BTL Inc.

Prepared by :

Joe Chang

Joe Chang, Engineer

Approved by :

Josh Lin

Josh Lin, Manager



BTL Inc.

No.18, Ln. 171, Sec. 2, Jiuzong Rd., Neihu Dist., Taipei City 114, Taiwan

Tel: +886-2-2657-3299 Fax: +886-2-2657-3331 Web: www.newbtl.com Service mail: btl_qa@newbtl.com

Declaration

BTL represents to the client that testing is done in accordance with standard procedures as applicable and that test instruments used has been calibrated with standards traceable to international standard(s) and/or national standard(s).

BTL's reports apply only to the specific samples tested under conditions. It is manufacture's responsibility to ensure that additional production units of this model are manufactured with the identical electrical and mechanical components. **BTL** shall have no liability for any declarations, inferences or generalizations drawn by the client or others from **BTL** issued reports.

This report is the confidential property of the client. As a mutual protection to the clients, the public and ourselves, the test report shall not be reproduced, except in full, without our written approval.

BTL's laboratory quality assurance procedures are in compliance with the **ISO/IEC 17025** requirements, and accredited by the conformity assessment authorities listed in this test report.

BTL is not responsible for the sampling stage, so the results only apply to the sample as received.

The information, data and test plan are provided by manufacturer which may affect the validity of results, so it is manufacturer's responsibility to ensure that the apparatus meets the essential requirements of applied standards and in all the possible configurations as representative of its intended use.

Limitation

For the use of the authority's logo is limited unless the Test Standard(s)/Scope(s)/Item(s) mentioned in this test report is (are) included in the conformity assessment authorities acceptance respective.

Please note that the measurement uncertainty is provided for informational purpose only and are not use in determining the Pass/Fail results.

CONTENTS

CONTENTS	3
REVISION HISTORY	4
1 SUMMARY OF TEST RESULTS	5
1.1 TEST FACILITY	6
1.2 MEASUREMENT UNCERTAINTY	6
1.3 TEST ENVIRONMENT CONDITIONS	6
2 GENERAL INFORMATION	7
2.1 EUT INFORMATION	7
2.2 TEST MODES	8
2.3 EUT OPERATING CONDITION	8
2.4 TESTED CONFIGURATION DIAGRAM	9
2.5 SUPPORT UNITS	9
3 EMC EMISSION TEST	10
3.1 CONDUCTED EMISSIONS TEST	10
3.1.1 LIMITS	10
3.1.2 MEASUREMENT INSTRUMENTS LIST	10
3.1.3 TEST PROCEDURE	11
3.1.4 DEVIATION FROM TEST STANDARD	11
3.1.5 TEST SETUP	11
3.1.6 TEST RESULT	12
3.2 RADIATED EMISSIONS BELOW 1 GHZ TEST	14
3.2.1 LIMITS - FCC	14
3.2.2 LIMITS - ICES	15
3.2.3 MEASUREMENT INSTRUMENTS LIST	16
3.2.4 TEST PROCEDURE	16
3.2.5 DEVIATION FROM TEST STANDARD	16
3.2.6 TEST SETUP	17
3.2.7 TEST RESULT - FCC	18
3.2.8 TEST RESULT - ICES	20
4 TEST PHOTOS	22
5 EUT PHOTOS	24

REVISION HISTORY

Report No.	Version	Description	Issued Date	Note
BTL-FCCE-1-2311T006	R00	Original Report.	2023/11/20	Valid

1 SUMMARY OF TEST RESULTS

Emission			
Standard	Test Item	Limit	Judgment
FCC CFR Title 47, Part 15, Subpart B ICES-003, Issue 7, October 15, 2020	AC power line conducted emissions	Class B	PASS
	Radiated emissions below 1 GHz NOTE (2)	Class B	PASS
	Radiated emissions above 1 GHz	-----	N/A

NOTE:

- (1) "N/A" denotes test is not applicable in this Test Report.
- (2) Due to the limits of applied standards are different, but the test setup and test procedure are identical, the test results of this item are multiple recorded with correspond limits.
- (3) The report format version is TP.1.1.3.

1.1 TEST FACILITY

Test Firm Location: No.18, Ln. 171, Sec. 2, Jiuzong Rd., Neihu Dist., Taipei City 114, Taiwan.

TAF Accreditation Number is 0659; FCC Designation Number is TW1115.

The satellite facilities under the test firm used to collect the test data in this report are:

No.18, Ln. 171, Sec. 2, Jiuzong Rd., Neihu Dist., Taipei City 114, Taiwan

C03 CB18 CB19

1.2 MEASUREMENT UNCERTAINTY

The reported uncertainty of measurement $y \pm U$, where expanded uncertainty U is based on a standard uncertainty multiplied by a coverage factor of $k = 2$, providing a level of confidence of approximately **95 %**.

The measurement instrumentation uncertainty considerations contained in CISPR 16-4-2. The BTL measurement uncertainty is less than the CISPR 16-4-2 U_{cispr} requirement.

A. AC power line conducted emissions test:

Test Site	Method	Measurement Frequency Range	U (dB)
C03	CISPR	150 kHz ~ 30 MHz	3.28

B. Radiated emissions below 1 GHz test:

Test Site	Method	Measurement Frequency Range	Ant. H / V	U (dB)
CB19 (3m)	CISPR	30 MHz ~ 200 MHz	V	3.88
		30 MHz ~ 200 MHz	H	3.80
		200 MHz ~ 1,000 MHz	V	4.04
		200 MHz ~ 1,000 MHz	H	3.82

NOTE:

Unless specifically mentioned, the uncertainty of measurement has not been taken into account to declare the compliance or non-compliance to the specification.

1.3 TEST ENVIRONMENT CONDITIONS

Test Item	Environment Condition	Tested by
Conducted emissions	20°C, 63%	Jimmy Tsai
Radiated emissions below 1 GHz	25°C, 58%	Loki Jiang

2 GENERAL INFORMATION

2.1 EUT INFORMATION

Equipment	Micro SD Card
Model Name	Industrial Micro SD R1-M, Industrial Micro SDHC R1-M, Industrial Micro SDXC R1-M, Industrial Micro SD R1-SL, Industrial Micro SDHC R1-SL, Industrial Micro SDXC R1-SL, Industrial Micro SDHC MSD-WORM, Industrial Micro SDXC MSD-WORM
Brand Name	Apacer
Model Difference	Differ in capacity.
Power Source	DC Voltage supplied from host system.
Power Rating	DC 2.7V~3.6V
Products Covered	N/A
Test Model	Industrial Micro SD R1-M
Sample Status	Engineering Sample
Highest Internal Frequency	50 MHz
EUT Modification(s)	N/A

NOTE:

- (1) The above EUT information is declared by manufacturer and for more detailed features description, please refers to the manufacturer's specifications or user's manual.

2.2 TEST MODES

The test system was pre-tested based on the consideration of all possible combinations of EUT operation modes according to test plan.

Pretest Mode	Description
Mode 1	R/W

Following mode(s) was (were) found to be the worst case(s) and selected for the final test.

AC power line conducted emissions test	
Final Test Mode	Description
Mode 1	R/W

Radiated emissions below 1 GHz test	
Final Test Mode	Description
Mode 1	R/W

2.3 EUT OPERATING CONDITION

The PC exercise program (BurninTEST V9.0) used during radiated and/or conducted emissions measurement was designed to exercise the various system components in a manner similar to a typical use.

2.4 TESTED CONFIGURATION DIAGRAM

Equipment letters and Cable numbers refer to item numbers described in the tables of clause 2.5.

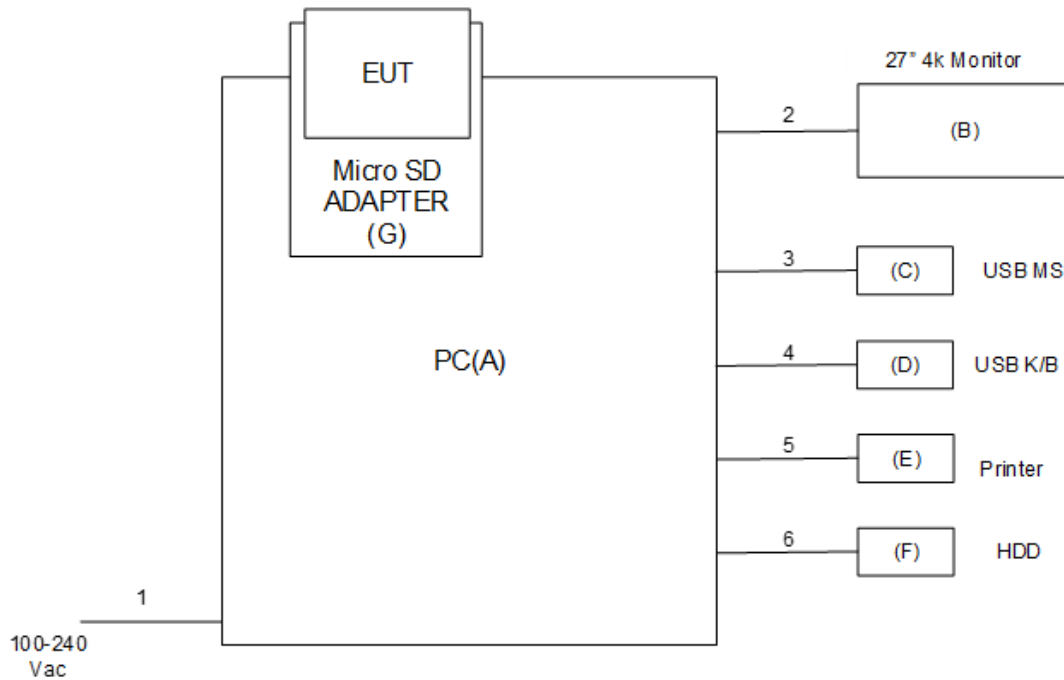

2.5 SUPPORT UNITS

Item	Equipment	Brand	Model No.	Series No.	Remarks
A (Conducted)	PC	DELL	Percision 3660	CT16K A00	Furnished by test lab.
A (Radiated)	PC	DELL	OptiPlex 7080	9T3HN A00	Furnished by test lab.
B	27" 4K Monitor	ASUS	MX27U	90LM02BB-B106D0	Furnished by test lab.
C	USB Mouse	DELL	MOCZUL	CN-049TWY-PRC00-79E-01HA	Furnished by test lab.
D	USB K/B	DELL	KB216t	CN-0W33XP-L0300-797-05TY-A03	Furnished by test lab.
E	Printer	HP	SNPRH-1504	N/A	Furnished by test lab.
F	2.5" USB 3.0 HDD	LACIE	1TB Rugged Mini USB3	NL33NGNK	Furnished by test lab.
G	Micro SD ADAPTER	Kingston	1CA21711-01038	3500007 002 A00LF 060818	Furnished by test lab.

Item	Cable Type	Shielded	Ferrite Core	Length	Remarks
1	POWER CABLE	NO	NO	1.8m	Type: 3-wire including ground Furnished by test lab.
2	DP CABLE	YES	NO	1.8m	Furnished by test lab.
3	USB CABLE	YES	NO	1.7m	Type: USB 2.0 Furnished by test lab.
4	USB CABLE	YES	NO	1.7m	Type: USB 2.0 Furnished by test lab.
5	USB CABLE	YES	NO	1.7m	Type: USB 2.0 Furnished by test lab.
6	USB CABLE	YES	NO	1.2m	Type: USB 3.2 GEN1 Furnished by test lab.

3 EMC EMISSION TEST

3.1 CONDUCTED EMISSIONS TEST

3.1.1 LIMITS

Frequency (MHz)	Class A (dB μ V)		Class B (dB μ V)	
	Quasi-peak	Average	Quasi-peak	Average
0.15 - 0.5	79	66	66 - 56 *	56 - 46 *
0.50 - 5.0	73	60	56	46
5.0 - 30.0	73	60	60	50

NOTE:

- (1) The tighter limit applies at the band edges.
- (2) The limit of " * " marked band means the limitation decreases linearly with the logarithm of the frequency in the range.
- (3) The test result calculated as following:
 Measurement Value = Reading Level + Correct Factor
 Correct Factor = Insertion Loss + Cable Loss + Attenuator Factor (if use)
 Margin Level = Measurement Value – Limit Value

Calculation example:

Reading Level (dB μ V)		Correct Factor (dB)		Measurement Value (dB μ V)
38.22	+	3.45	=	41.67

Measurement Value (dB μ V)		Limit Value (dB μ V)		Margin Level (dB)
41.67	-	60	=	-18.33

3.1.2 MEASUREMENT INSTRUMENTS LIST

Item	Kind of Equipment	Manufacturer	Type No.	Serial No.	Calibrated Date	Calibrated Until
1	TWO-LINE V-NETWORK	R&S	ENV216	101522	2023/9/25	2024/9/24
2	Test Cable	EMCI	EMCCFD400-NM-NM-5000	151209	2022/12/16	2023/12/15
3	EMI Test Receiver	R&S	ESR	101854	2022/12/12	2023/12/11
4	Measurement Software	Farad	EZ EMC (Ver. NB-03A1-01)	N/A	N/A	N/A

REMARK:

- (1) "N/A" denotes no model name, no serial no. or no calibration specified.
- (2) All calibration period of equipment list is one year.

3.1.3 TEST PROCEDURE

- a. The EUT was placed 0.8 m above the horizontal ground plane with the EUT being connected to the power mains through a line impedance stabilization network (LISN).
All other support equipment were powered from an additional LISN(s).
The LISN provides 50 Ohm/50uH of impedance for the measuring instrument.
- b. Interconnecting cables that hang closer than 40 cm to the ground plane shall be folded back and forth in the center forming a bundle to keep the cable above 40 cm.
- c. Excess I/O cables that are not connected to a peripheral shall be bundled in the center.
The end of the cable will be terminated, using the correct terminating impedance.
The overall length shall not exceed 1 m.
- d. The LISN is spaced at least 80 cm from the nearest part of the EUT chassis.
- e. The receiver was set to quasi-peak and average detect function and specified bandwidth with maximum hold mode.
- f. For the actual test configuration, please refer to the related Item - TEST PHOTOS.

3.1.4 DEVIATION FROM TEST STANDARD

No deviation.

3.1.5 TEST SETUP

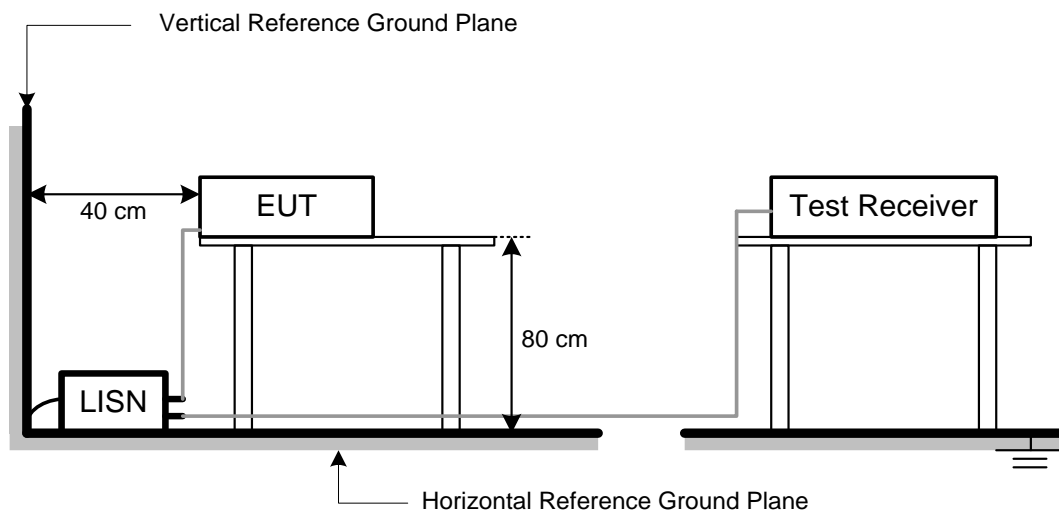

3.1.6 TEST RESULT

Test Mode	Mode 1	Tested Date	2023/11/14
Test Voltage	AC 120V/60Hz	Phase	Line

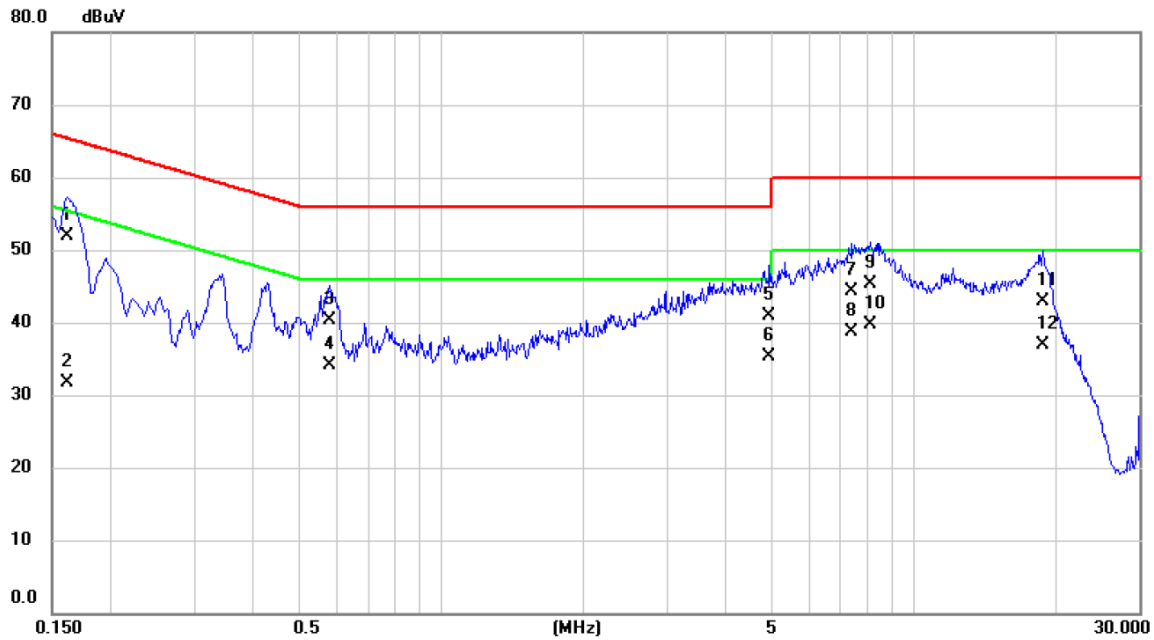

No.	Mk.	Freq.	Reading Level	Correct Factor	Measurement	Limit	Margin	Detector	Comment
		MHz	dBuV	dB	dBuV	dBuV	dB		
1		0.1613	42.20	9.69	51.89	65.40	-13.51	QP	
2		0.1613	22.10	9.69	31.79	55.40	-23.61	AVG	
3		0.5797	30.70	9.70	40.40	56.00	-15.60	QP	
4		0.5797	24.50	9.70	34.20	46.00	-11.80	AVG	
5		4.9290	31.20	9.75	40.95	56.00	-15.05	QP	
6		4.9290	25.50	9.75	35.25	46.00	-10.75	AVG	
7		7.3950	34.60	9.80	44.40	60.00	-15.60	QP	
8		7.3950	28.90	9.80	38.70	50.00	-11.30	AVG	
9		8.0925	35.40	9.81	45.21	60.00	-14.79	QP	
10	*	8.0925	29.80	9.81	39.61	50.00	-10.39	AVG	
11		18.7238	33.10	9.79	42.89	60.00	-17.11	QP	
12		18.7238	27.10	9.79	36.89	50.00	-13.11	AVG	

REMARKS:

- (1) Measurement Value = Reading Level + Correct Factor.
- (2) Margin Level = Measurement Value - Limit Value.

Test Mode	Mode 1	Tested Date	2023/11/14
Test Voltage	AC 120V/60Hz	Phase	Neutral

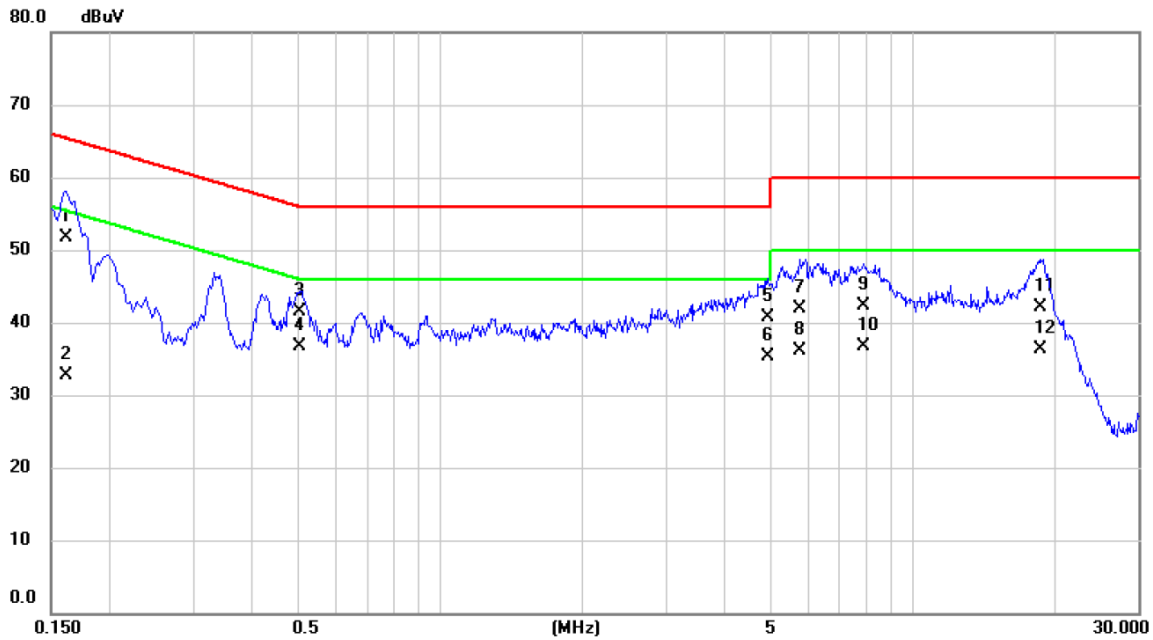

No.	Mk.	Freq.	Reading Level	Correct Factor	Measurement	Limit	Margin	Detector	Comment
		MHz	dBuV	dB	dBuV	dBuV	dB		
1		0.1613	42.10	9.69	51.79	65.40	-13.61	QP	
2		0.1613	23.10	9.69	32.79	55.40	-22.61	AVG	
3		0.5032	31.80	9.70	41.50	56.00	-14.50	QP	
4	*	0.5032	27.10	9.70	36.80	46.00	-9.20	AVG	
5		4.9223	30.90	9.78	40.68	56.00	-15.32	QP	
6		4.9223	25.50	9.78	35.28	46.00	-10.72	AVG	
7		5.7480	32.10	9.79	41.89	60.00	-18.11	QP	
8		5.7480	26.30	9.79	36.09	50.00	-13.91	AVG	
9		7.8428	32.50	9.83	42.33	60.00	-17.67	QP	
10		7.8428	26.80	9.83	36.63	50.00	-13.37	AVG	
11		18.5640	32.30	9.88	42.18	60.00	-17.82	QP	
12		18.5640	26.40	9.88	36.28	50.00	-13.72	AVG	

REMARKS:

- (1) Measurement Value = Reading Level + Correct Factor.
- (2) Margin Level = Measurement Value - Limit Value.

3.2 RADIATED EMISSIONS BELOW 1 GHZ TEST

3.2.1 LIMITS - FCC

FCC CFR Title 47, Part 15, Subpart B:

Frequency (MHz)	Class A (at 10 m)		Class A (at 3 m)*	Class B (at 3 m)	
	(uV/m) Field strength	(dBuV/m) Field strength	(dBuV/m) Field strength	(uV/m) Field strength	(dBuV/m) Field strength
30 - 88	90	39	49.46	100	40
88 - 216	150	43.5	53.96	150	43.5
216 - 960	210	46.4	56.86	200	46
Above 960	300	49.5	59.96	500	54

* FCC CFR Title 47, Part 15, Subpart A, section 15.31(f)(1), the distance could be extrapolated by using 20 dB/decade factor.

Alternative Limits:

Frequency (MHz)	Class A (at 10 m)	Class B (at 10 m)
	dB μ V/m	dB μ V/m
30 - 230	40	30
230 - 1000	47	37

FCC CFR Title 47, Part 15, Subpart B, section 15.109(g) provides, as an alternative, compliance to the CISPR 22 (Third Edition) radiated emission limits in the 30 MHz to 1000 MHz range.

Frequency range of radiated measurements (For unintentional radiators)

Highest frequency generated or Upper frequency of measurement used in the device or on which the device operates or tunes (MHz)	Range (MHz)
Below 1.705	30
1.705 - 108	1000
108 - 500	2000
500 - 1000	5000
Above 1000	5 th harmonic of the highest frequency or 40 GHz, whichever is lower

NOTE:

- (1) The tighter limit applies at the band edges.
- (2) Emission level (dBuV/m) = 20log Emission level (uV/m).
3 m Emission level = 10 m Emission level + 20log(10 m/3 m).
- (3) The test result calculated as following:

Measurement Value = Reading Level + Correct Factor

Correct Factor = Antenna Factor + Cable Loss - Amplifier Gain (if use)

Margin Level = Measurement Value - Limit Value

Calculation example:

Reading Level (dB μ V)		Correct Factor (dB/m)		Measurement Value (dB μ V/m)
19.11	+	2.11	=	21.22

Measurement Value (dB μ V/m)		Limit Value (dB μ V/m)		Margin Level (dB)
21.22	-	40	=	-18.78

3.2.2 LIMITS - ICES

Frequency range (MHz)	Class A		Class B	
	Quasi-peak		Quasi-peak	
	(dBuV/m) (at 3 m)	(dBuV/m) (at 10 m)	(dBuV/m) (at 3 m)	(dBuV/m) (at 10 m)
30 – 88	50.0	40.0	40.0	30.0
88 – 216	54.0	43.5	43.5	33.1
216 – 230	56.9	46.4	46.0	35.6
230 – 960	57.0	47.0	47.0	37.0
960 – 1000	60.0	49.5	54.0	43.5

Required highest measurement frequency for radiated emissions

Highest internal frequency (F_x)	Highest measurement frequency (F_M)
$F_x \leq 108$ MHz	1 GHz
108 MHz $< F_x \leq 500$ MHz	2 GHz
500 MHz $< F_x \leq 1$ GHz	5 GHz
$F_x > 1$ GHz	$5 \times F_x$ up to a maximum of 40 GHz

NOTE:

- (4) The more stringent limit applies at transition frequencies.
- (5) F_x is the highest fundamental frequency generated and/or used in the ITE or digital apparatus under test.
- (6) Emission level (dB μ V/m) = 20log Emission level (μ V/m).
3 m Emission level = 10 m Emission level + 20log(10 m/3 m).
- (7) The test result calculated as following:
Measurement Value = Reading Level + Correct Factor
Correct Factor = Antenna Factor + Cable Loss - Amplifier Gain (if use)
Margin Level = Measurement Value - Limit Value

Calculation example:

Reading Level (dB μ V)		Correct Factor (dB/m)		Measurement Value (dB μ V/m)
19.11	+	2.11	=	21.22

Measurement Value (dB μ V/m)		Limit Value (dB μ V/m)		Margin Level (dB)
21.22	-	40	=	-18.78

3.2.3 MEASUREMENT INSTRUMENTS LIST

Item	Kind of Equipment	Manufacturer	Type No.	Serial No.	Calibrated Date	Calibrated Until
1	Log-Bicon Antenna	Schwarzbeck	VULB 9168	00984	2023/8/24	2024/8/23
2	Attenuator	EMCI	6N-5dB	01	2023/8/24	2024/8/23
3	Pre-Amplifier	EMCI	EMC001330	980403	2023/5/26	2024/5/25
4	Test Cable	EMCI	EMCCFD400-NM-NM-1500	170340	2023/5/26	2024/5/25
5	Test Cable	EMCI	EMC104-SM-SM-2500	170401	2023/5/26	2024/5/25
6	Test Cable	EMCI	EMCCFD400-NM-NM-8000	170341	2023/5/26	2024/5/25
7	EMI Test Receiver	Keysight	N9038A	MY55420127	2023/6/15	2024/6/14
8	Measurement Software	Farad	EZ EMC (Ver. NB-03A1-01)	N/A	N/A	N/A

REMARK:

- (1) "N/A" denotes no model name, no serial no. or no calibration specified.
- (2) All calibration period of equipment list is one year.

3.2.4 TEST PROCEDURE

- a. The separation distance of 3 m was used for measurements below 1 GHz. The EUT was placed on the top of a rotating table 0.8 m above the ground in a 3 m semi-anechoic chamber.
- b. The table was rotated 360 degrees to determine the position of the highest radiation.
- c. The height of the receive antenna was varied between 1 m and 4 m. Both horizontal and vertical polarizations of the antenna were checked.
- d. For each suspected emission, the EUT was arranged at its worst case and then the antenna was scanned in height to find the maximum. The tower Bore sight function was used.
- e. The receiver was set to quasi-peak detect function and specified bandwidth with maximum hold mode.
- f. For the actual test configuration, please refer to the related Item - TEST PHOTOS.

3.2.5 DEVIATION FROM TEST STANDARD

No deviation.

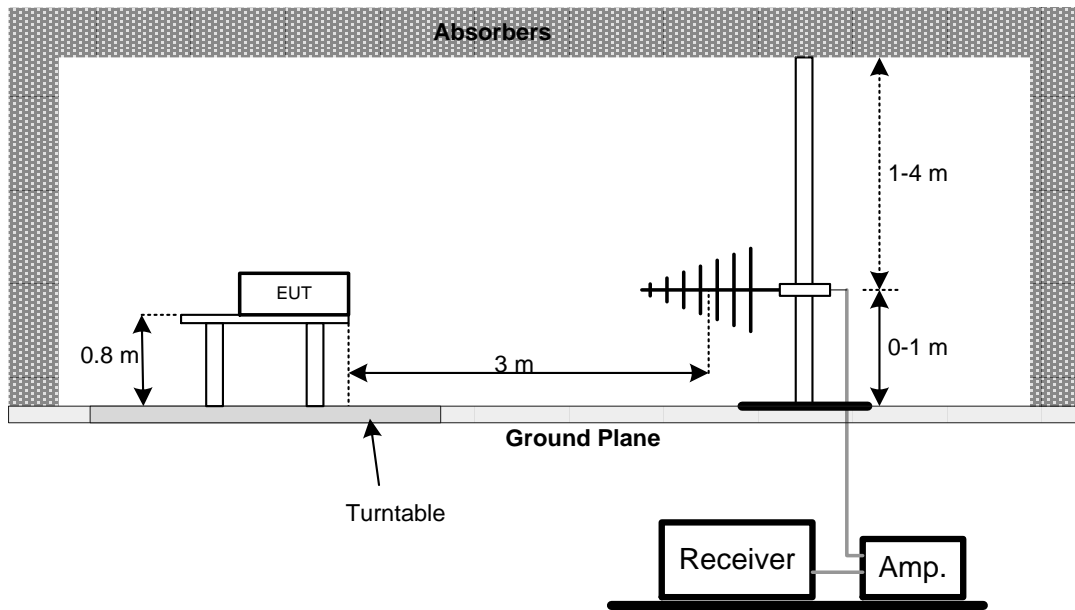
3.2.6 TEST SETUP

3.2.7 TEST RESULT - FCC

Test Mode	Mode 1	Tested Date	2023/11/8
Test Voltage	AC 120V/60Hz	Polarization	Vertical

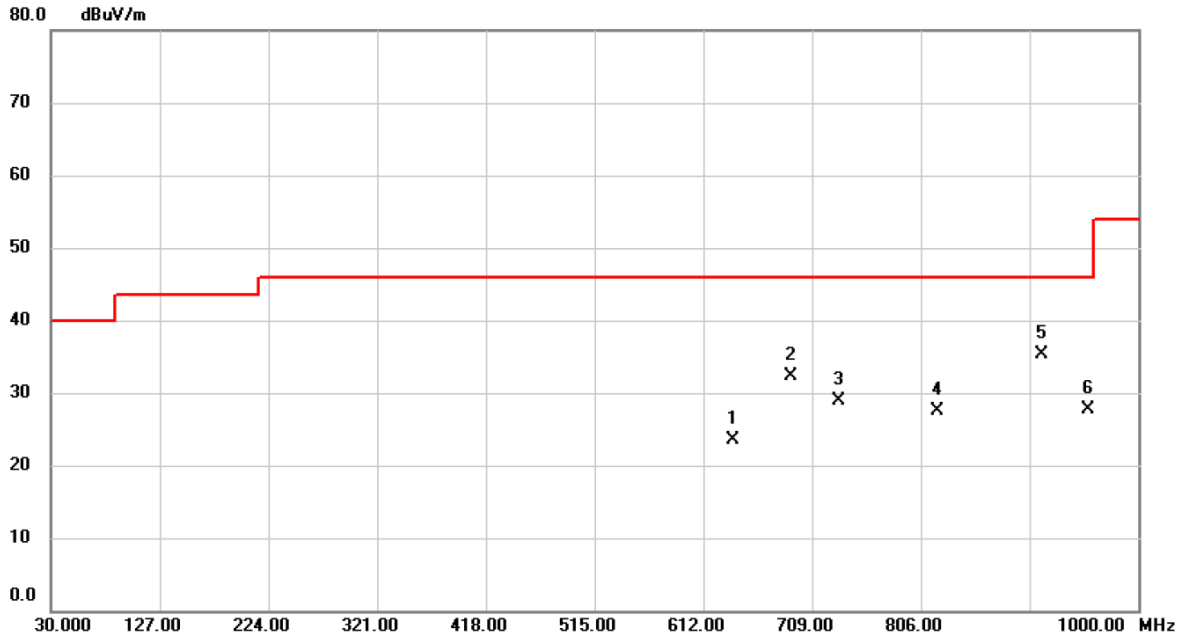

No. Mk.	Freq. MHz	Reading Level dBuV	Correct Factor dB/m	Measurement dBuV/m	Limit dBuV/m	Over dB	Detector	Antenna Height cm	Table Degree	Comment
1	638.1900	25.11	-1.51	23.60	46.00	-22.40	QP	100	19	
2	689.6000	32.82	-0.61	32.21	46.00	-13.79	QP	200	360	
3	732.2800	28.58	0.38	28.96	46.00	-17.04	QP	180	360	
4	820.5500	26.22	1.29	27.51	46.00	-18.49	QP	100	193	
5 *	913.6700	32.90	2.34	35.24	46.00	-10.76	QP	200	360	
6	955.3800	24.55	3.06	27.61	46.00	-18.39	QP	200	225	

REMARKS:

- (1) Measurement Value = Reading Level + Correct Factor.
- (2) Margin Level = Measurement Value - Limit Value.

Test Mode	Mode 1	Tested Date	2023/11/8
Test Voltage	AC 120V/60Hz	Polarization	Horizontal

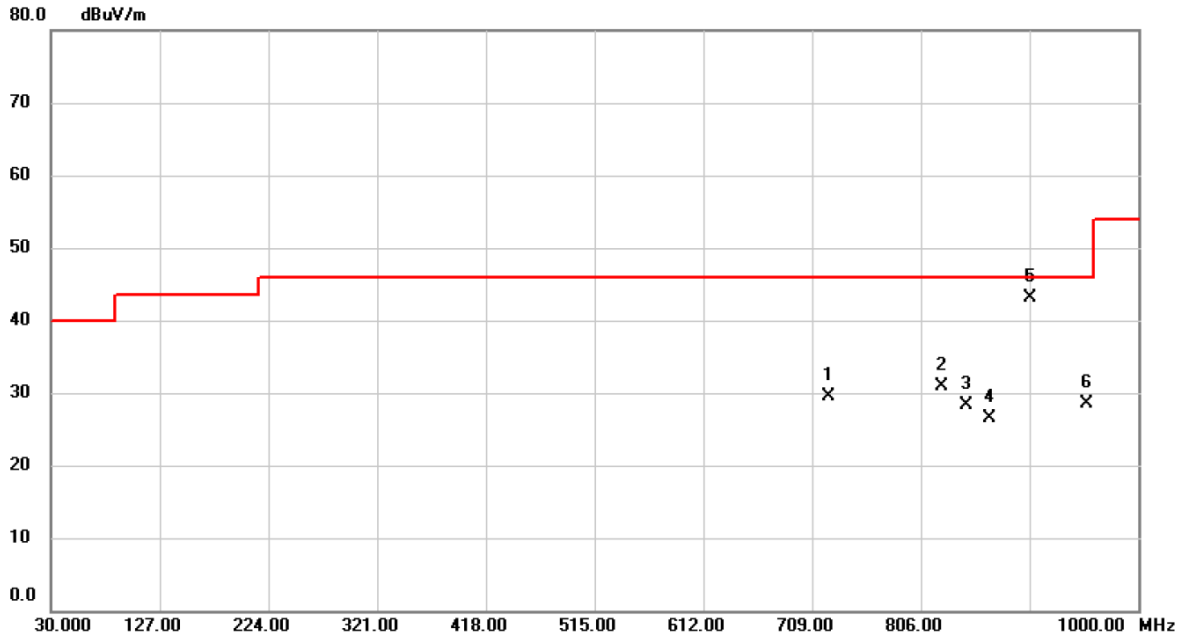

No.	Mk.	Freq.	Reading Level	Correct Factor	Measurement	Limit	Over	Antenna Height	Table Degree	
		MHz	dBuV	dB/m	dBuV/m	dBuV/m	dB	cm	degree	Comment
1		723.5500	29.26	0.15	29.41	46.00	-16.59	200	78	
2		824.4300	29.56	1.33	30.89	46.00	-15.11	100	0	
3		846.7400	26.73	1.48	28.21	46.00	-17.79	100	360	
4		867.1100	24.82	1.71	26.53	46.00	-19.47	200	10	
5	*	903.9700	40.96	2.16	43.12	46.00	-2.88	142	360	
6		953.4400	25.52	3.05	28.57	46.00	-17.43	119	360	

REMARKS:

- (1) Measurement Value = Reading Level + Correct Factor.
- (2) Margin Level = Measurement Value - Limit Value.

3.2.8 TEST RESULT - ICES

Test Mode	Mode 1	Tested Date	2023/11/8
Test Voltage	AC 120V/60Hz	Polarization	Vertical

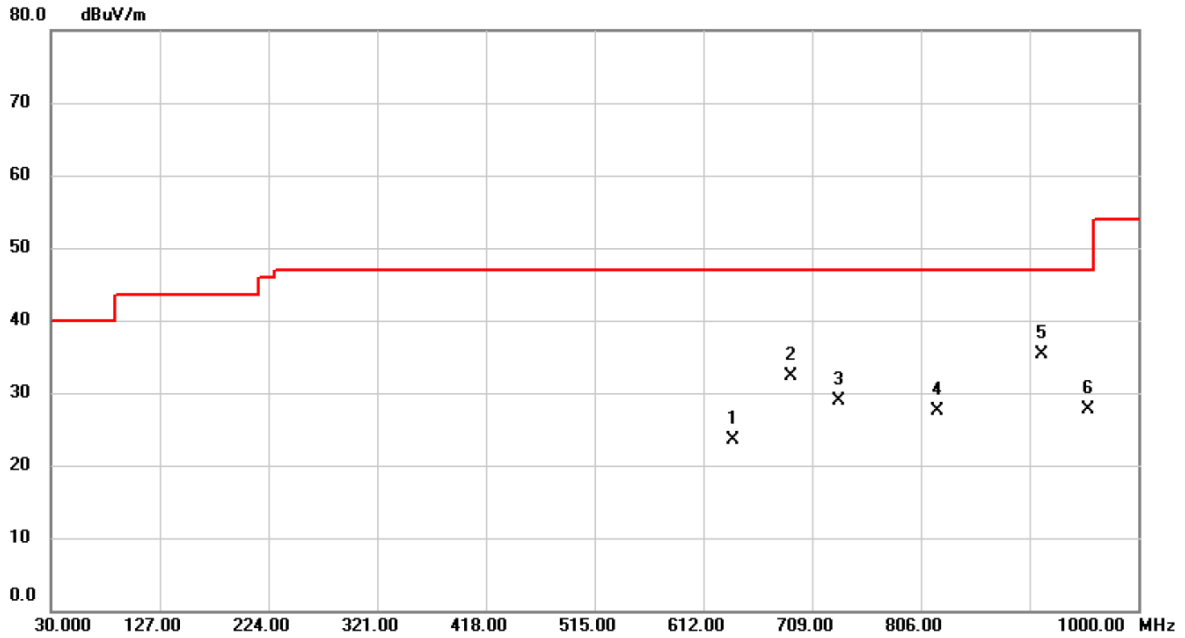

No. Mk.	Freq. MHz	Reading Level dBuV	Correct Factor dB/m	Measurement dBuV/m	Limit dBuV/m	Over dB	Detector	Antenna Height cm	Table Degree	Comment
1	638.1900	25.11	-1.51	23.60	47.00	-23.40	QP	100	19	
2	689.6000	32.82	-0.61	32.21	47.00	-14.79	QP	200	360	
3	732.2800	28.58	0.38	28.96	47.00	-18.04	QP	180	360	
4	820.5500	26.22	1.29	27.51	47.00	-19.49	QP	100	193	
5 *	913.6700	32.90	2.34	35.24	47.00	-11.76	QP	200	360	
6	955.3800	24.55	3.06	27.61	47.00	-19.39	QP	200	225	

REMARKS:

- (1) Measurement Value = Reading Level + Correct Factor.
- (2) Margin Level = Measurement Value - Limit Value.

Test Mode	Mode 1	Tested Date	2023/11/8
Test Voltage	AC 120V/60Hz	Polarization	Horizontal

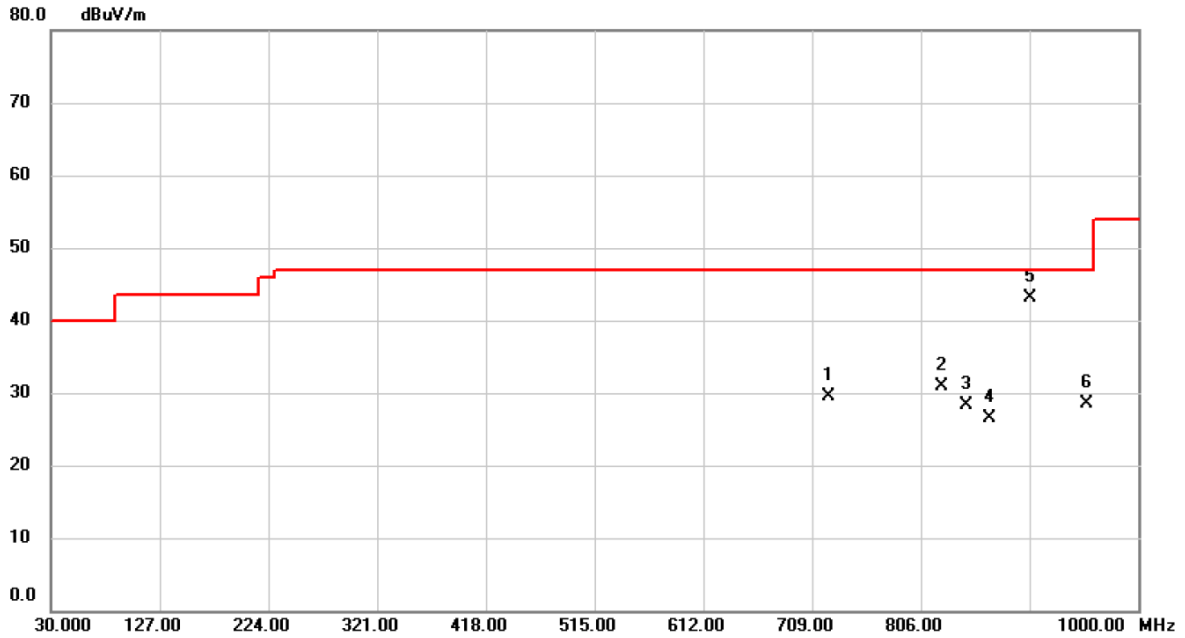

No.	Mk.	Freq.	Reading Level	Correct Factor	Measurement	Limit	Over	Antenna Height	Table Degree	
		MHz	dBuV	dB/m	dBuV/m	dBuV/m	dB	cm	degree	Comment
1		723.5500	29.26	0.15	29.41	47.00	-17.59	QP	200	78
2		824.4300	29.56	1.33	30.89	47.00	-16.11	QP	100	0
3		846.7400	26.73	1.48	28.21	47.00	-18.79	QP	100	360
4		867.1100	24.82	1.71	26.53	47.00	-20.47	QP	200	10
5	*	903.9700	40.96	2.16	43.12	47.00	-3.88	QP	142	360
6		953.4400	25.52	3.05	28.57	47.00	-18.43	QP	119	360

REMARKS:

- (1) Measurement Value = Reading Level + Correct Factor.
- (2) Margin Level = Measurement Value - Limit Value.

4 TEST PHOTOS

AC power line conducted emissions test photos



Radiated emissions below 1 GHz test photos

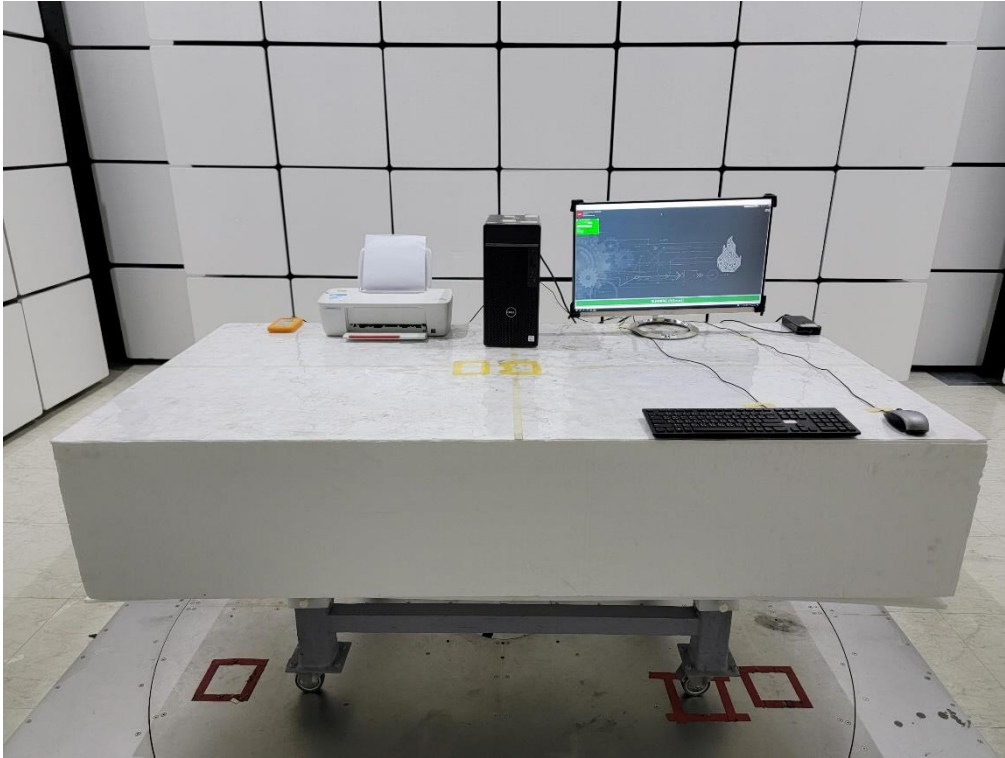

5 EUT PHOTOS

Please refer to document Appendix No.: EP-2311T006-1 (APPENDIX-EUT PHOTOS).

End of Test Report