



CERTIFICATE

Issued Date: Sep. 08, 2011
Report No.: 119028R-ITUSP01V02

This is to certify that the following designated product

Product : CFast
Trade name : Apacer
Model Number : APCFAXXXGT6XS-XXXX
Company Name : Apacer Technology Inc.

This product, which has been issued the test report listed as above in QuietTek Laboratory, is based on a single evaluation of one sample and confirmed to comply with the requirements of the following EMC standard.

FCC CFR Title 47 Part 15 Subpart B: 2010, Class B, CISPR 22: 2008
ANSI C63.4: 2009

TEST LABORATORY

Vincent Lin / Manager

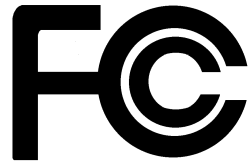

Test Report

Product Name : CFast

Model No. : APCFAXXXGT6XS-XXXX

Applicant : Apacer Technology Inc.

Address : 3F, No.83, Kur Wong Rd., Aspire Park, Lung
Tan Hsiang, Tao Yuan Hsien, Taiwan

Date of Receipt : 2011/08/29

Issued Date : 2011/09/08

Report No. : 119028R-ITUSP01V02

Report Version : V1.0

The test results relate only to the samples tested.

The test results shown in the test report are traceable to the national/international standard through the calibration of the equipment and evaluated measurement uncertainty herein.

This report must not be used to claim product endorsement by TAF, NVLAP, NIST or any agency of the Government.
The test report shall not be reproduced except in full without the written approval of QuieTek Corporation.

DECLARATION OF CONFORMITY

Per FCC Part 2 Section 2. 1077(a)



The following equipment:

Product : CFast _____
Trade name : Apacer _____
Model Number : APCFAXXXGT6XS-XXXX _____

It's herewith confirmed to comply with the requirements of FCC Part 15 Rules.
Operation is subject to the following two conditions:

- (1) This device may not cause harmful interference, and
- (2) This device must accept any interference received, including interference that may cause undesired operation.

The result of electromagnetic emission has been evaluated by QuieTek EMC laboratory (NVLAP Lab. Code : 200533-0) and showed in the test report.
(Report No. : 119028R-ITUSP01V02)

It is understood that each unit marketed is identical to the device as tested, and any changes to the device that could adversely affect the emission characteristics will require retest.

The following importer / manufacturer is responsible for this declaration:

Company Name _____
Company Address _____
Telephone _____ Facsimile : _____

Person is responsible for marking this declaration:

_____ Name (Full name)	_____ Position / Title
_____ Date	_____ Legal Signature

Test Report Certification

Issued Date : 2011/09/08
 Report No. : 119028R-ITUSP01V02



Product Name : CFast
 Applicant : Apacer Technology Inc.
 Address : 3F, No.83, Kur Wong Rd., Aspire Park, Lung Tan Hsiang,
 Tao Yuan Hsien, Taiwan
 Manufacturer : Apacer Technology Inc.
 Model No. : APCFAXXXGT6XS-XXXX
 EUT Rated Voltage : Power by PC
 EUT Test Voltage : AC 120 V / 60 Hz
 Trade Name : Apacer
 Applicable : FCC CFR Title 47 Part 15 Subpart B: 2010, Class B
 Standard : CISPR 22: 2008, ANSI C63.4: 2009
 Test Result : Complied
 Performed Location : Quietek Corporation (Linkou Laboratory)
 No.5-22, Ruishukeng, Linkou Dist., New Taipei City 24451,
 Taiwan, R.O.C.
 TEL:+866-2-8601-3788 / FAX:+886-2-8601-3789

Documented By : April Chen
 (Adm. Assistant / April Chen)

Reviewed By : JoJolee jung
 (Senior Engineer / JoJolee Jung)

Approved By : [Signature]
 (Manager / Vincent Lin)

Laboratory Information

We, **Quietek Corporation**, are an independent EMC and safety consultancy that was established the whole facility in our laboratories. The test facility has been accredited/accepted (audited or listed) by the following related bodies in compliance with ISO 17025, EN 45001 and specified testing scopes:

Taiwan R.O.C.	:	BSMI, NCC, TAF
Germany	:	TUV Rheinland
Norway	:	Nemko, DNV
USA	:	FCC, NVLAP
Japan	:	VCCI

The related certificate for our laboratories about the test site and management system can be downloaded from Quietek Corporation's Web Site : <http://www.quietek.com/tw/ctg/cts/accreditations.htm>

The address and introduction of Quietek Corporation's laboratories can be founded in our Web site : <http://www.quietek.com/>

If you have any comments, Please don't hesitate to contact us. Our contact information is as below:

HsinChu Testing Laboratory :

No.75-2, 3rd Lin, Wangye Keng, Yonghxing Tsuen, Qionglin Shiang, Hsinchu County 307, Taiwan, R.O.C.

TEL:+886-3-592-8858 / FAX:+886-3-592-8859

E-Mail : service@quietek.com



LinKou Testing Laboratory :

No.5-22, Ruishukeng, Linkou Dist., New Taipei City 24451, Taiwan, R.O.C.

TEL : 886-2-8601-3788 / FAX : 886-2-8601-3789

E-Mail : service@quietek.com



Suzhou (China) Testing Laboratory :

No. 99 Hongye Rd., Suzhou Industrial Park Loufeng Hi-Tech Development Zone., Suzhou,China.

TEL : +86-512-6251-5088 / FAX : +86-512-6251-5098

E-Mail : service@quietek.com



TABLE OF CONTENTS

Description	Page
1. General Information	5
1.1. EUT Description.....	5
1.2. Mode of Operation	5
1.3. Tested System Details	6
1.4. Configuration of Tested System	6
1.5. EUT Exercise Software.....	7
2. Technical Test	8
2.1. Summary of Test Result.....	8
2.2. List of Test Equipment	9
2.3. Measurement Uncertainty.....	10
2.4. Test Environment.....	11
3. Conducted Emission	12
3.1. Test Specification	12
3.2. Test Setup.....	12
3.3. Limit	12
3.4. Test Procedure	13
3.5. Test Result	14
3.6. Test Photograph	20
4. Radiated Emission	21
4.1. Test Specification	21
4.2. Test Setup.....	21
4.3. Limit	22
4.4. Test Procedure	23
4.5. Test Result	24
4.6. Test Photograph	29
5. Attachment.....	30
EUT Photograph.....	31

1. General Information

1.1. EUT Description

Product Name	CFast
Trade Name	Apacer
Model No.	APCFAXXXGT6XS-XXXX

1.2. Mode of Operation

Quietek has verified the construction and function in typical operation. All the test modes were carried out with the EUT in normal operation, which was shown in this test report and defined as:

Pre-Test Mode	
Mode 1: Normal Operation	
Final Test Mode	
Emission	Mode 1: Normal Operation

1.3. Tested System Details

The types for all equipments, plus descriptions of all cables used in the tested system (including inserted cards) are:

Product	Manufacturer	Model No.	Serial No.	Power Cord
1 Monitor	DELL	U2410	CN-0J257M-728-011-04ML	Non-Shielded, 1.8m
2 PC	DELL	Vostro230	1R7Z62S	Non-Shielded, 1.8m
3 Keyboard	COMPAQ	KB-0133	B55940FBUOE04B	N/A
4 Mouse	Logitech	M-SBM96B	810-000440	N/A

1.4. Configuration of Tested System

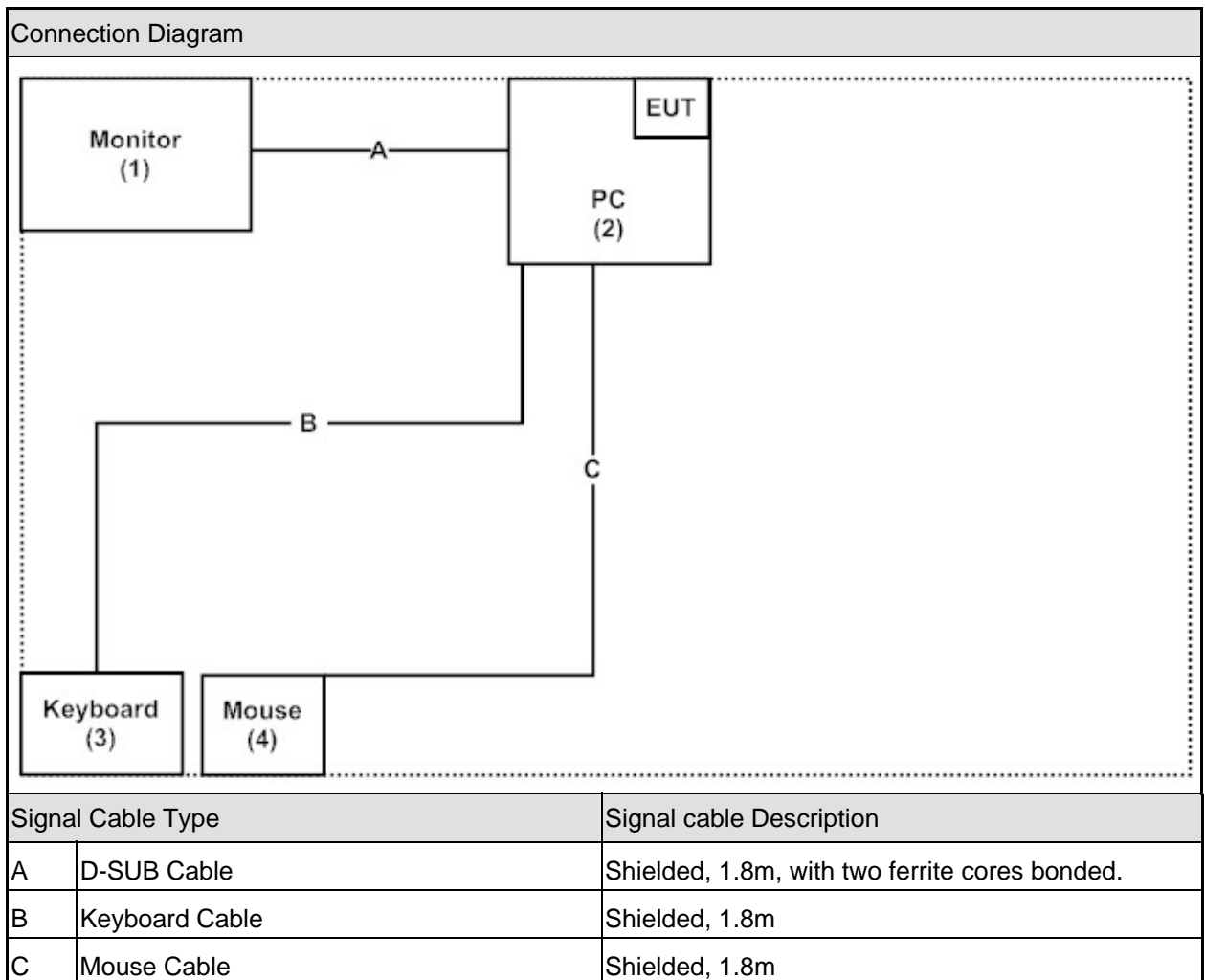

1.5. EUT Exercise Software

1	Setup the EUT and simulators as shown on 1.4.
2	Turn on the power of all equipment.
3	Boot the PC from Hard Disk.
4	Data will be communicated between computer and EUT.
5	All the peripheral will be retrieved during the test.
6	Repeat the above procedure (4) to (5).

2. Technical Test

2.1. Summary of Test Result

- No deviations from the test standards
- Deviations from the test standards as below description:

Emission			
Performed Item	Normative References	Test Performed	Deviation
Conducted Emission	FCC CFR Title 47 Part 15 Subpart B: 2010 Class B, ANSI C63.4: 2009	Yes	No
Radiated Emission	FCC CFR Title 47 Part 15 Subpart B: 2010 Class B, ANSI C63.4: 2009	Yes	No

2.2. List of Test Equipment

Conducted Emission / SR2

Instrument	Manufacturer	Type No.	Serial No	Cal. Date
EMI Test Receiver	R&S	ESCI	100647	2010/11/24
LISN	R&S	ESH3-Z5	836679/017	2011/02/05
LISN	R&S	ENV216	100086	2011/02/05
Impedance Stabilization Network	Teseq	ISN T800	29414	2011/08/10

Radiated Emission / Site3

Instrument	Manufacturer	Type No.	Serial No	Cal. Date
Bilog Antenna	Schaffner Chase	CBL6112B	2704	2011/07/28
EMI Test Receiver	R&S	ESCS 30	100367	2010/09/14
Pre-Amplifier	QTK	LK-E-I-AMP4	N/A	2011/07/07
CXA Signal Analyzer	Agilent	N9000A	MY50510070	2011/02/10

Radiated Emission / 9x6x6_Chamber

Instrument	Manufacturer	Type No.	Serial No	Cal. Date
EMI Test Receiver	R&S	ESIB26	838786/004	2011/06/29
Horn Antenna	Schwarzbeck	9120D	576	2010/11/12
Pre-Amplifier	Quietek	AP-025C	CHM/071919	2011/07/12

2.3. Measurement Uncertainty

Conducted Emission

The measurement uncertainty is evaluated as ± 2.26 dB.

Radiated Emission

The measurement uncertainty is evaluated as ± 3.19 dB.

2.4. Test Environment

Performed Item	Items	Required	Actual
Conducted Emission	Temperature (°C)	15-35	25
	Humidity (%RH)	25-75	50
	Barometric pressure (mbar)	860-1060	950-1000
Radiated Emission	Temperature (°C)	15-35	25
	Humidity (%RH)	25-75	50
	Barometric pressure (mbar)	860-1060	950-1000

3. Conducted Emission

3.1. Test Specification

According to Standard : FCC Part 15 Subpart B, ANSI C63.4

3.2. Test Setup

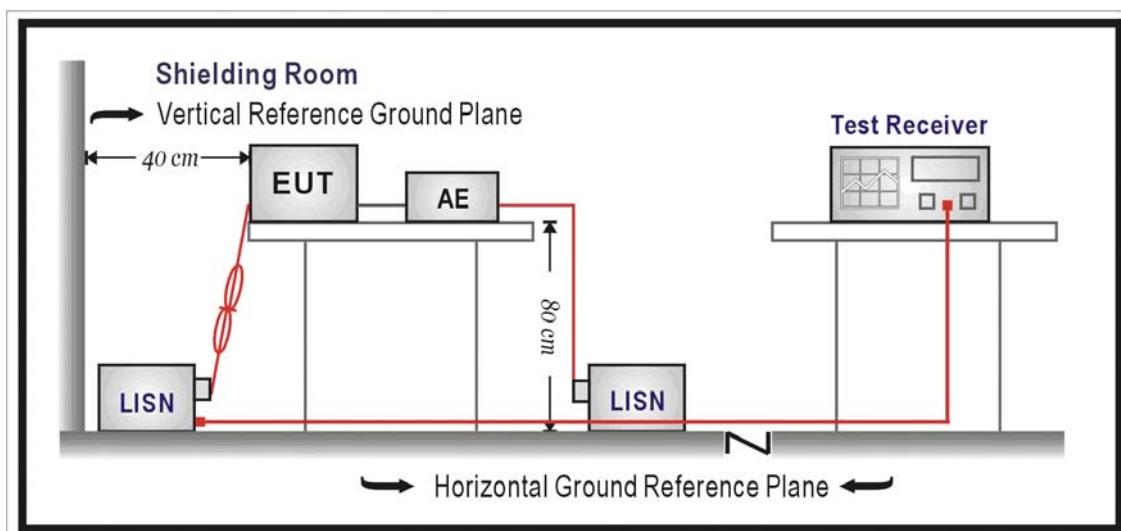

3.3. Limit

Limits		
Frequency (MHz)	QP (dBuV)	AV (dBuV)
0.15 - 0.50	66 - 56	56 - 46
0.50-5.0	56	46
5.0 - 30	60	50

Remarks: In the above table, the tighter limit applies at the band edges.

3.4. Test Procedure

The EUT and simulators are connected to the main power through a line impedance stabilization network (L.I.S.N.). This provides a 50 ohm /50uH coupling impedance for the measuring equipment. The peripheral devices are also connected to the main power through a LISN that provides a 50ohm/50uH coupling impedance with 50ohm termination.

(Please refers to the block diagram of the test setup and photographs.)

Both sides of A.C. line are checked for maximum conducted interference. In order to find the maximum emission, the relative positions of equipment and all of the interface cables must be changed on conducted measurement.

Conducted emissions were invested over the frequency range from 0.15MHz to 30MHz using a receiver bandwidth of 9kHz.

3.5. Test Result

Site : SR2	Time : 2011/08/30 - 18:49
Limit : CISPR_B_00M_QP	Margin : 10
EUT : CFast	Probe : ENV_216_L1 - Line1
Power : AC 120V/60Hz	Note : Mode 1

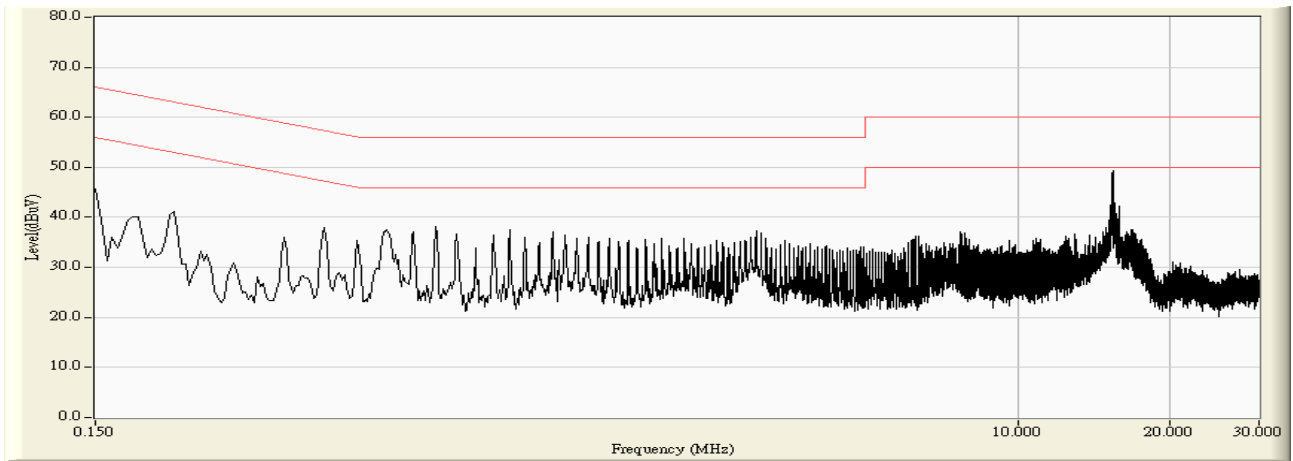

Site : SR2	Time : 2011/08/30 - 18:56
Limit : CISPR_B_00M_QP	Margin : 0
EUT : CFast	Probe : ENV_216_L1 - Line1
Power : AC 120V/60Hz	Note : Mode 1

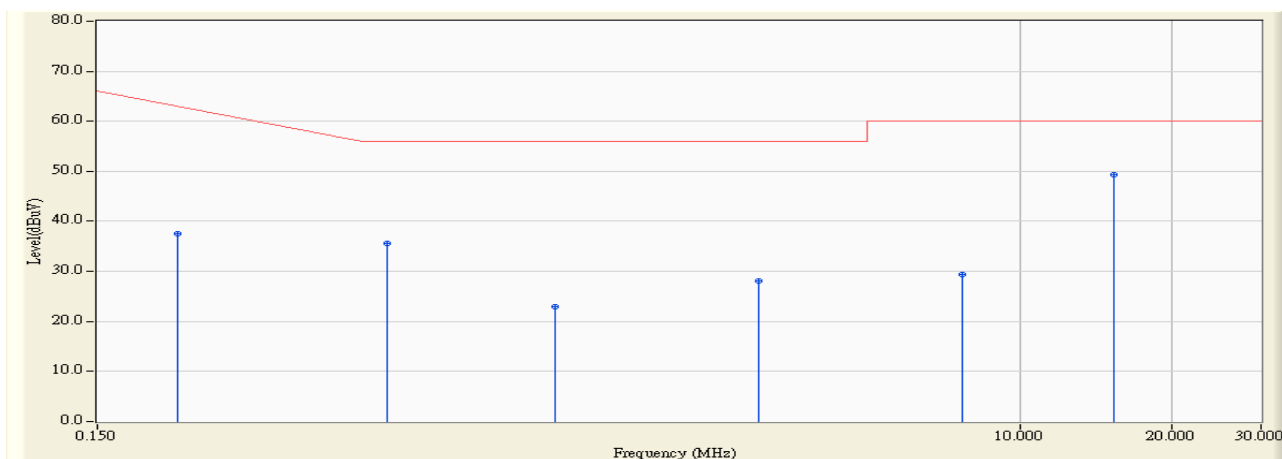

		Frequency (MHz)	Correct Factor (dB)	Reading Level (dBuV)	Measure Level (dBuV)	Margin (dB)	Limit (dBuV)	Detector Type
1		0.216	9.790	27.799	37.589	-26.525	64.114	QUASIPeAK
2		0.562	9.780	25.891	35.671	-20.329	56.000	QUASIPeAK
3		1.202	9.770	13.147	22.917	-33.083	56.000	QUASIPeAK
4		3.038	9.820	18.315	28.135	-27.865	56.000	QUASIPeAK
5		7.702	9.860	19.600	29.460	-30.540	60.000	QUASIPeAK
6	*	15.402	10.110	39.305	49.415	-10.585	60.000	QUASIPeAK

Note:

1. All Reading Levels are Quasi-Peak and average value.
2. " * ", means this data is the worst emission level.
3. Measurement Level = Reading Level + Correct Factor

Site : SR2	Time : 2011/08/30 - 18:56
Limit : CISPR_B_00M_AV	Margin : 0
EUT : CFast	Probe : ENV_216_L1 - Line1
Power : AC 120V/60Hz	Note : Mode 1

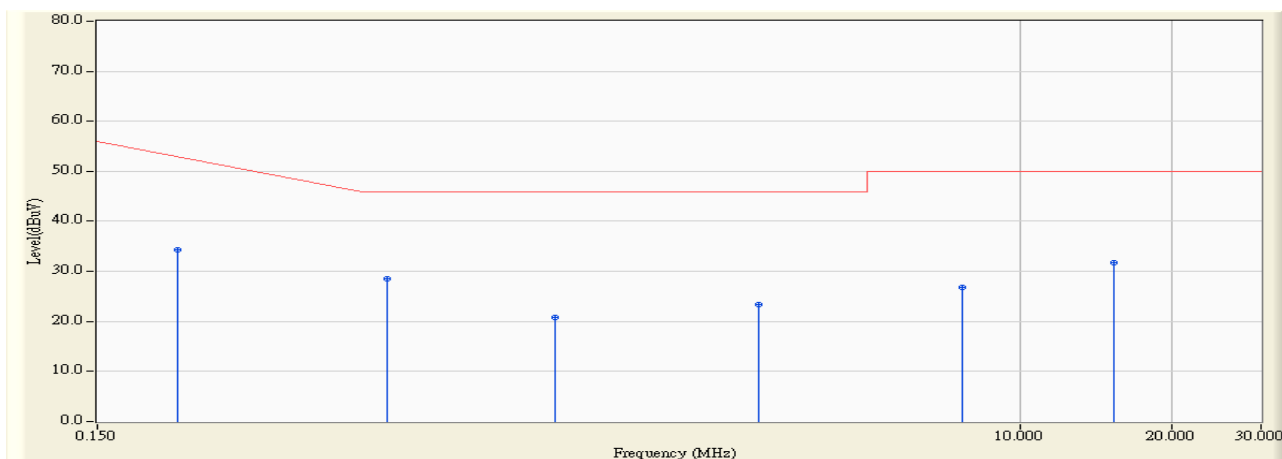

		Frequency (MHz)	Correct Factor (dB)	Reading Level (dBuV)	Measure Level (dBuV)	Margin (dB)	Limit (dBuV)	Detector Type
1		0.216	9.790	24.512	34.302	-19.812	54.114	AVERAGE
2	*	0.562	9.780	18.654	28.434	-17.566	46.000	AVERAGE
3		1.202	9.770	10.971	20.741	-25.259	46.000	AVERAGE
4		3.038	9.820	13.576	23.396	-22.604	46.000	AVERAGE
5		7.702	9.860	16.913	26.773	-23.227	50.000	AVERAGE
6		15.402	10.110	21.534	31.644	-18.356	50.000	AVERAGE

Note:

1. All Reading Levels are Quasi-Peak and average value.
2. " * ", means this data is the worst emission level.
3. Measurement Level = Reading Level + Correct Factor

Site : SR2	Time : 2011/08/30 - 18:59
Limit : CISPR_B_00M_QP	Margin : 10
EUT : CFast	Probe : ENV_216_N - Line2
Power : AC 120V/60Hz	Note : Mode 1

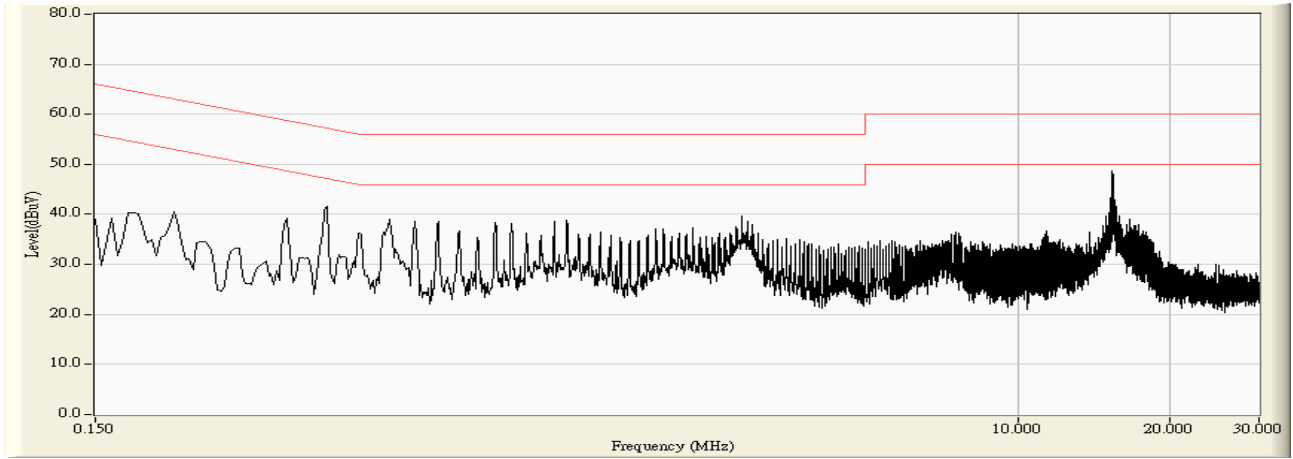

Site : SR2	Time : 2011/08/30 - 19:00
Limit : CISPR_B_00M_QP	Margin : 0
EUT : CFast	Probe : ENV_216_N - Line2
Power : AC 120V/60Hz	Note : Mode 1

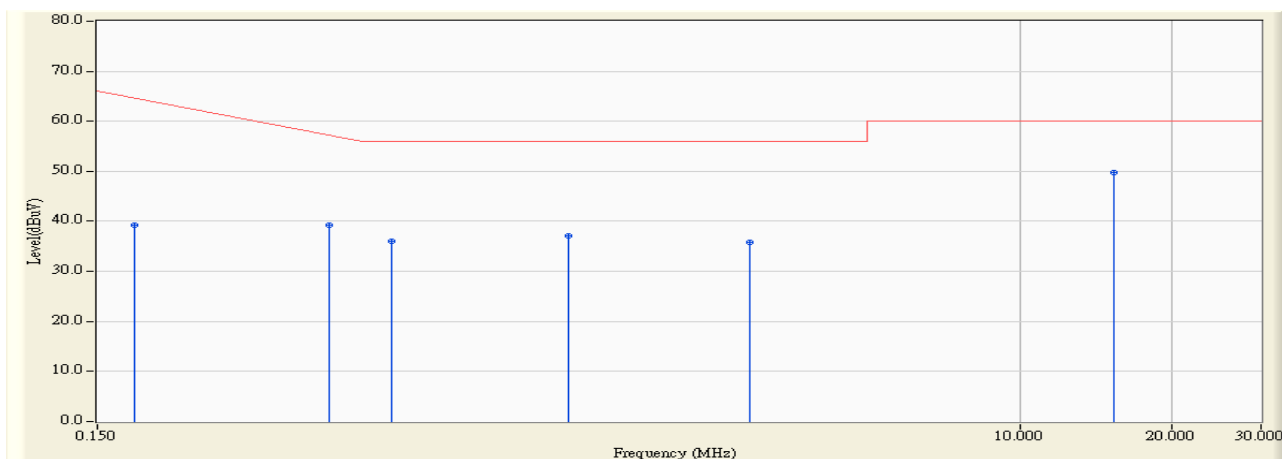

		Frequency (MHz)	Correct Factor (dB)	Reading Level (dBuV)	Measure Level (dBuV)	Margin (dB)	Limit (dBuV)	Detector Type
1		0.178	9.790	29.425	39.215	-25.985	65.200	QUASIPeAK
2		0.430	9.790	29.425	39.215	-18.785	58.000	QUASIPeAK
3		0.574	9.790	26.330	36.120	-19.880	56.000	QUASIPeAK
4		1.282	9.790	27.249	37.039	-18.961	56.000	QUASIPeAK
5		2.922	9.810	26.005	35.815	-20.185	56.000	QUASIPeAK
6	*	15.402	10.200	39.634	49.834	-10.166	60.000	QUASIPeAK

Note:

1. All Reading Levels are Quasi-Peak and average value.
2. " * ", means this data is the worst emission level.
3. Measurement Level = Reading Level + Correct Factor

Site : SR2	Time : 2011/08/30 - 19:00
Limit : CISPR_B_00M_AV	Margin : 0
EUT : CFast	Probe : ENV_216_N - Line2
Power : AC 120V/60Hz	Note : Mode 1

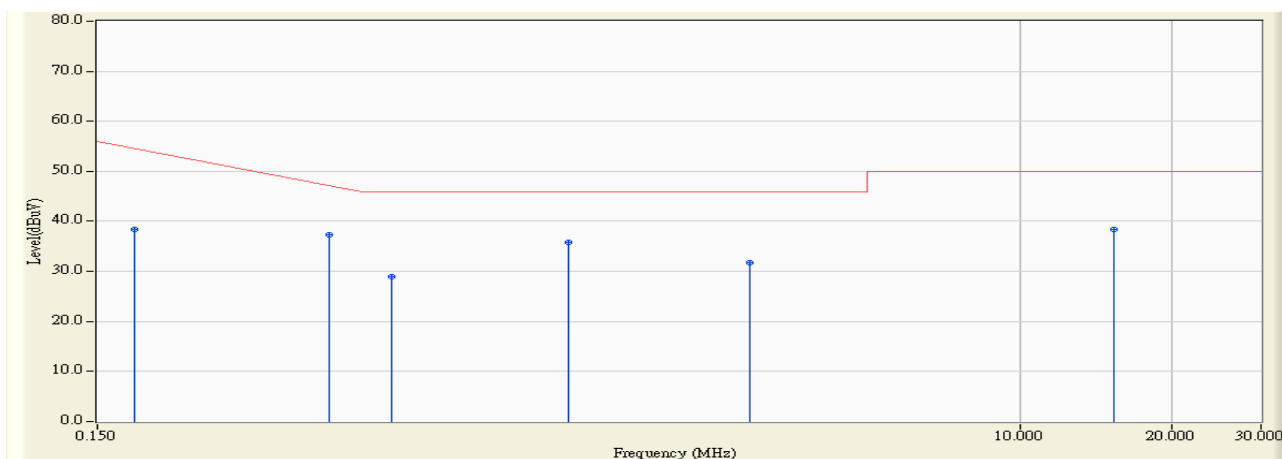

		Frequency (MHz)	Correct Factor (dB)	Reading Level (dBuV)	Measure Level (dBuV)	Margin (dB)	Limit (dBuV)	Detector Type
1		0.178	9.790	28.612	38.402	-16.798	55.200	AVERAGE
2		0.430	9.790	27.508	37.298	-10.702	48.000	AVERAGE
3		0.574	9.790	19.091	28.881	-17.119	46.000	AVERAGE
4	*	1.282	9.790	25.998	35.788	-10.212	46.000	AVERAGE
5		2.922	9.810	21.923	31.733	-14.267	46.000	AVERAGE
6		15.402	10.200	28.248	38.448	-11.552	50.000	AVERAGE

Note:

1. All Reading Levels are Quasi-Peak and average value.
2. " * ", means this data is the worst emission level.
3. Measurement Level = Reading Level + Correct Factor

3.6. Test Photograph

Test Mode : Mode 1: Normal Operation

Description : Front View of Conducted Test



Test Mode : Mode 1: Normal Operation

Description : Back View of Conducted Test



4. Radiated Emission

4.1. Test Specification

According to EMC Standard : FCC Part 15 Subpart B, ANSI C63.4

4.2. Test Setup

Under 1GHz Test Setup:

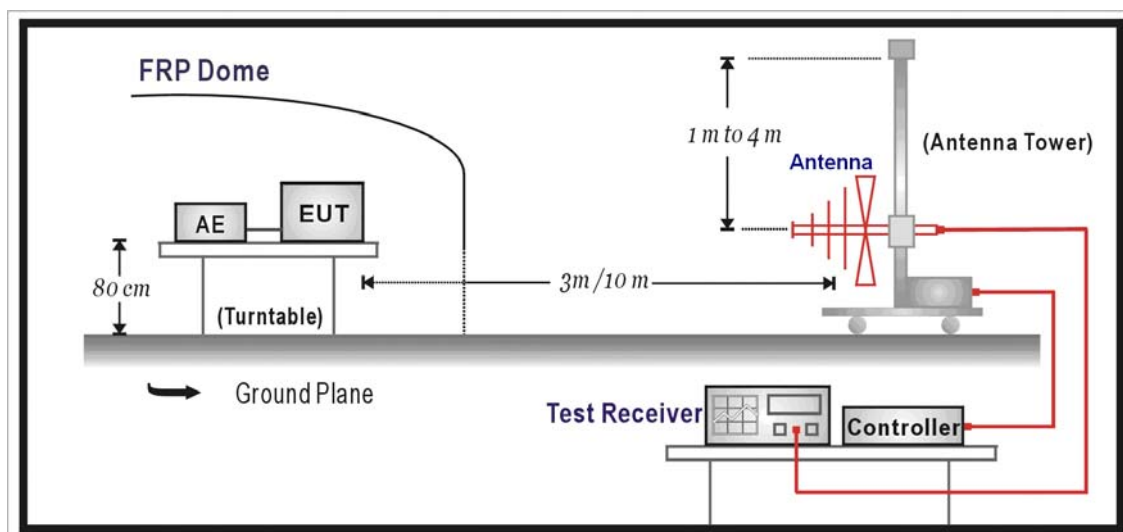

Above 1GHz Test Setup:

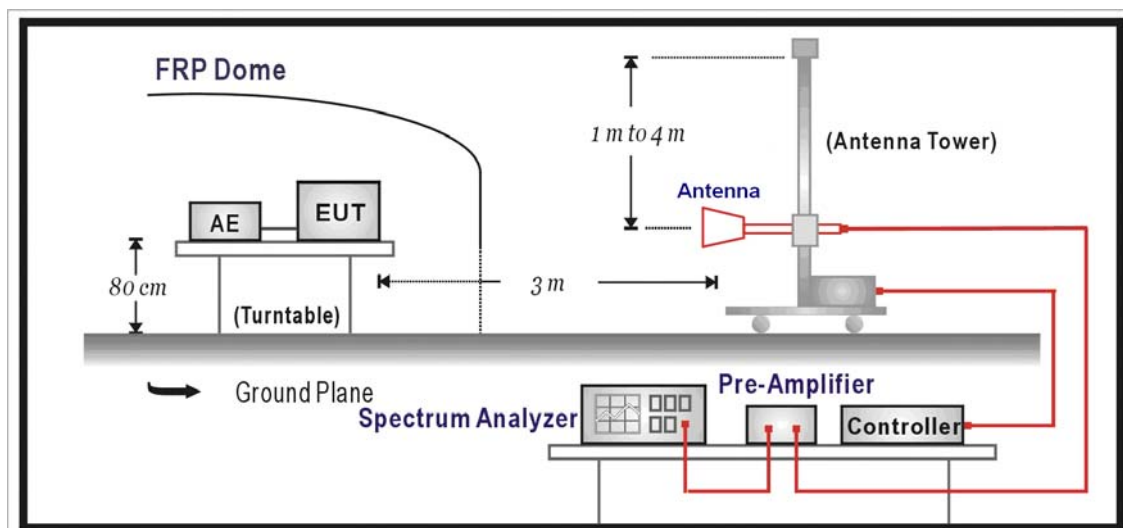

4.3. Limit

Under 1GHz test shall not exceed the following value:

Limits		
Frequency (MHz)	Distance (m)	dBuV/m
30 – 230	10	30
230 – 1000	10	37

Remark:

1. The tighter limit shall apply at the edge between two frequency bands.
2. Distance refers to the distance in meters between the measuring instrument antenna and the closed point of any part of the device or system.

Above 1GHz test shall not exceed the following value:

FCC Part 15 Subpart B Paragraph 15.109 Limits (dBuV/m)		
Frequency (MHz)	Distance (m)	dBuV/m
30-88	3	40
88-216	3	43.5
216-960	3	46
Above 960	3	54

Remark:

1. The tighter limit shall apply at the edge between two frequency bands.
2. Distance refers to the distance in meters between the measuring instrument antenna and the closed point of any part of the device or system.
3. RF Voltage (dBuV/m) = 20 log RF Voltage (uV/m)

4.4. Test Procedure

The EUT and its simulators are placed on a turn table which is 0.8 meter above ground.

The turn table can rotate 360 degrees to determine the position of the maximum emission level and the antenna can move up and down between 1 meter and 4 meters to find out the maximum emission level.

Both horizontal and vertical polarization of the antenna are set on measurement. In order to find the maximum emission, all of the interface cables must be manipulated on radiated measurement.

For an unintentional radiator, including a digital device, the spectrum shall be investigated from the lowest radio frequency signal generated or used in the device, without going below the lowest frequency for which a radiated emission limit is specified, up to the frequency shown in the following table:

Highest frequency generated or used in the device or on which the device operates or tunes (MHz)	Upper frequency of measurement range (MHz)
Below 1.705	30
1.705 – 108	1000
108 – 500	2000
500 – 1000	5000
Above 1000	5 th harmonic of the highest frequency or 40 GHz, whichever is lower

On any frequency or frequencies below or equal to 1000 MHz, the radiated limits shown are based on measuring equipment employing a quasi-peak detector function and above 1000 MHz, the radiated limits shown are based measuring equipment employing an average detector function.

When average radiated emission measurement are included emission measurement Above 1000 MHz, there also is a limit on the radio frequency emissions, as measured using instrumentation with a peak detector function, corresponding to 20 dB above the maximum permitted average limit.

For class A, the measurement distance between the EUT and antenna is 10 meters for under 1GHz and above 1GHz.

For class B, the measurement distance between the EUT and antenna is 10 meters for under 1GHz and 3 meters for above 1GHz.

The bandwidth below 1GHz setting on the field strength meter (R&S Test Receiver ESCS 30) is 120 kHz and above 1GHz is 1MHz.

4.5. Test Result

Site : OATS-3	Time : 2011/08/30 - 11:53
Limit : CISPR_B_10M_QP	Margin : 6
EUT : CFast	Probe : Site3_CBL6112_10M_0726 - HORIZONTAL
Power : AC 120V/60Hz	Note : Mode 1

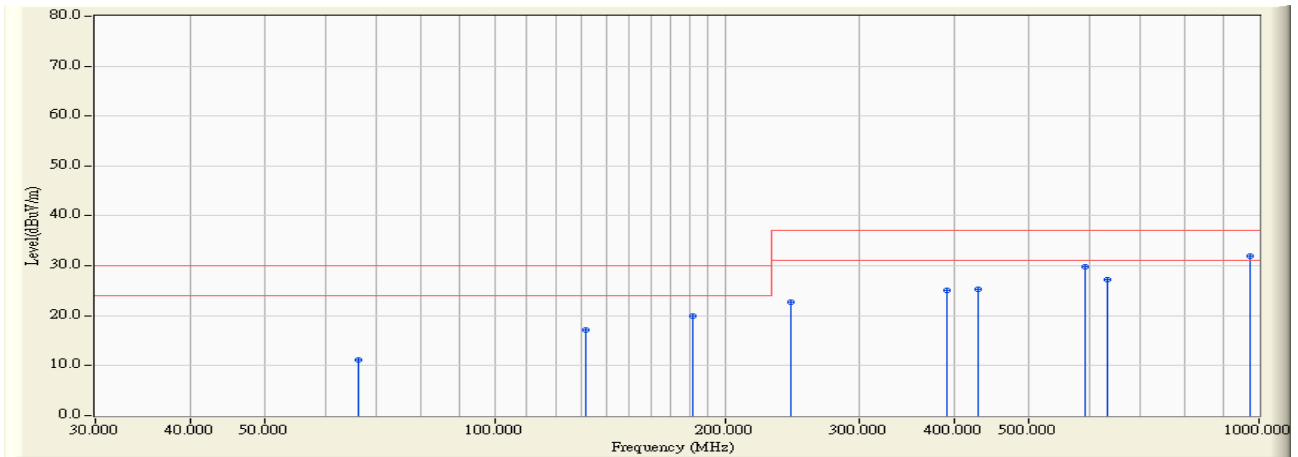

	Frequency (MHz)	Correct Factor (dB)	Reading Level (dBuV)	Measure Level (dBuV/m)	Margin (dB)	Limit (dBuV/m)	Detector Type
1	66.420	8.321	2.900	11.221	-18.779	30.000	QUASPEAK
2	131.500	14.764	2.400	17.164	-12.836	30.000	QUASPEAK
3	181.260	12.429	7.500	19.929	-10.071	30.000	QUASPEAK
4	244.100	15.793	7.000	22.793	-14.207	37.000	QUASPEAK
5	390.100	19.827	5.200	25.027	-11.973	37.000	QUASPEAK
6	429.600	20.700	4.600	25.299	-11.701	37.000	QUASPEAK
7	592.400	23.756	6.100	29.856	-7.144	37.000	QUASPEAK
8	634.000	24.220	3.100	27.320	-9.680	37.000	QUASPEAK
9	* 975.000	28.764	3.100	31.865	-5.135	37.000	QUASPEAK

Note:

1. All Readings below 1GHz are Quasi-Peak, above are performed with peak and/or average measurements as necessary.
2. " * ", means this data is the worst emission level.
3. Measurement Level = Reading Level + Correct Factor

Site : OATS-3	Time : 2011/08/30 - 11:48
Limit : CISPR_B_10M_QP	Margin : 6
EUT : CFast	Probe : Site3_CBL6112_10M_0726 - VERTICAL
Power : AC 120V/60Hz	Note : Mode 1

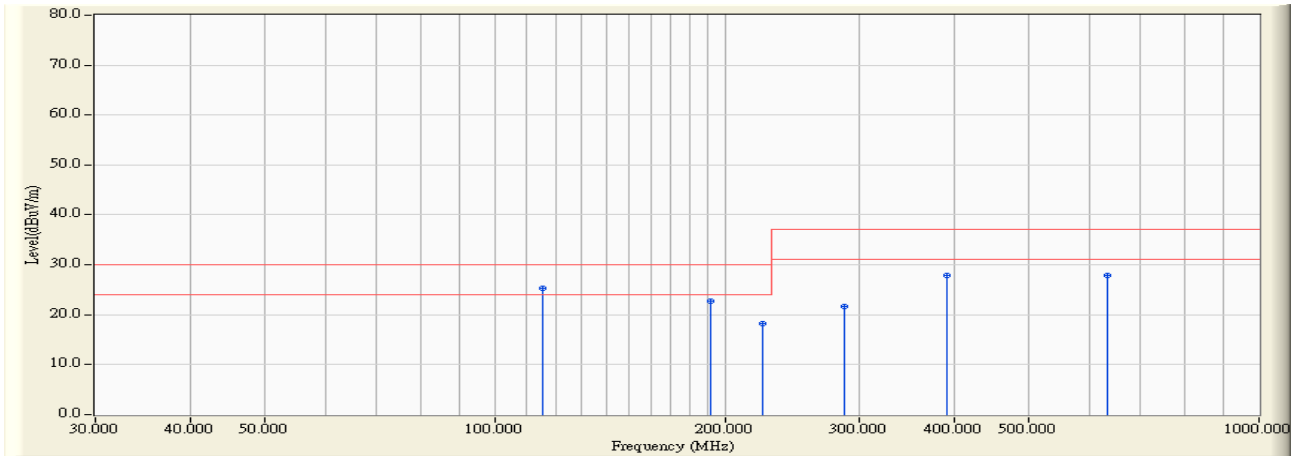

		Frequency (MHz)	Correct Factor (dB)	Reading Level (dBuV)	Measure Level (dBuV/m)	Margin (dB)	Limit (dBuV/m)	Detector Type
1	*	115.720	15.045	10.200	25.245	-4.755	30.000	QUASPEAK
2		191.740	12.597	10.200	22.797	-7.203	30.000	QUASPEAK
3		224.200	14.404	3.900	18.304	-11.696	30.000	QUASPEAK
4		286.300	17.147	4.600	21.747	-15.253	37.000	QUASPEAK
5		390.100	19.827	8.000	27.827	-9.173	37.000	QUASPEAK
6		634.000	24.220	3.600	27.820	-9.180	37.000	QUASPEAK

Note:

1. All Readings below 1GHz are Quasi-Peak, above are performed with peak and/or average measurements as necessary.
2. " * ", means this data is the worst emission level.
3. Measurement Level = Reading Level + Correct Factor

Site : CB7	Time : 2011/08/30 - 14:45
Limit : FCC_B_(Above_1G)_03M_PK	Margin : 6
EUT : CFast	Probe : 9120D_1-18G_Horn - HORIZONTAL
Power : AC 120V/60Hz	Note : Mode 1

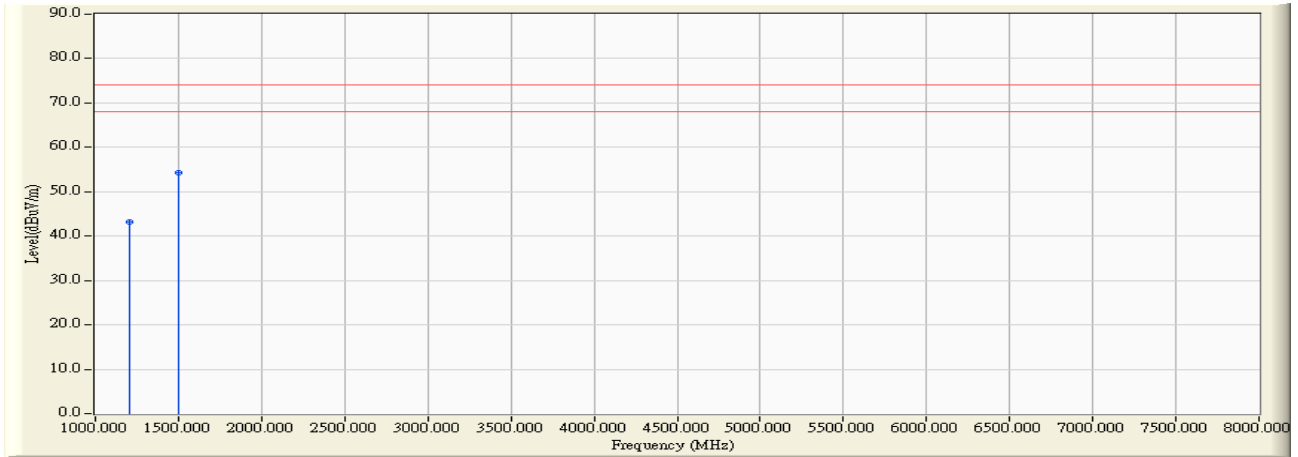

		Frequency (MHz)	Correct Factor (dB)	Reading Level (dBuV)	Measure Level (dBuV/m)	Margin (dB)	Limit (dBuV/m)	Detector Type
1		1205.000	-7.976	51.220	43.245	-30.755	74.000	PEAK
2	*	1505.000	-7.055	61.300	54.246	-19.754	74.000	PEAK

Note:

1. All Readings below 1GHz are Quasi-Peak, above are performed with peak and/or average measurements as necessary.
2. " * ", means this data is the worst emission level.
3. Measurement Level = Reading Level + Correct Factor

Site : CB7	Time : 2011/08/30 - 14:45
Limit : FCC_B_(Above_1G)_03M_AV	Margin : 6
EUT : CFast	Probe : 9120D_1-18G_Horn - HORIZONTAL
Power : AC 120V/60Hz	Note : Mode 1

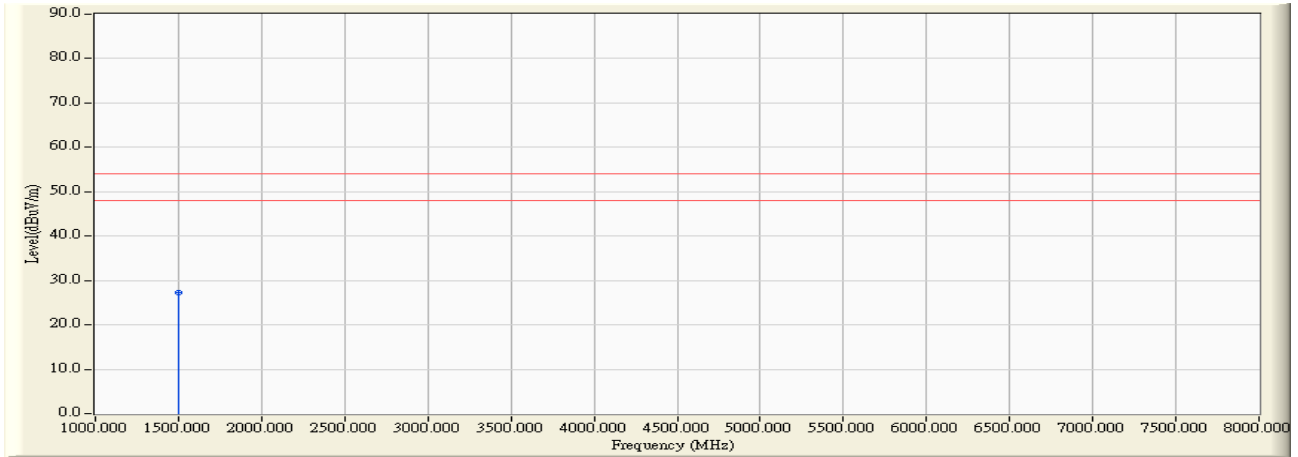

		Frequency (MHz)	Correct Factor (dB)	Reading Level (dBuV)	Measure Level (dBuV/m)	Margin (dB)	Limit (dBuV/m)	Detector Type
1	*	1505.000	-7.055	34.320	27.266	-26.734	54.000	AVERAGE

Note:

1. All Readings below 1GHz are Quasi-Peak, above are performed with peak and/or average measurements as necessary.
2. " * ", means this data is the worst emission level.
3. Measurement Level = Reading Level + Correct Factor

Site : CB7	Time : 2011/08/30 - 14:50
Limit : FCC_B_(Above_1G)_03M_PK	Margin : 6
EUT : CFast	Probe : 9120D_1-18G_Horn - VERTICAL
Power : AC 120V/60Hz	Note : Mode 1

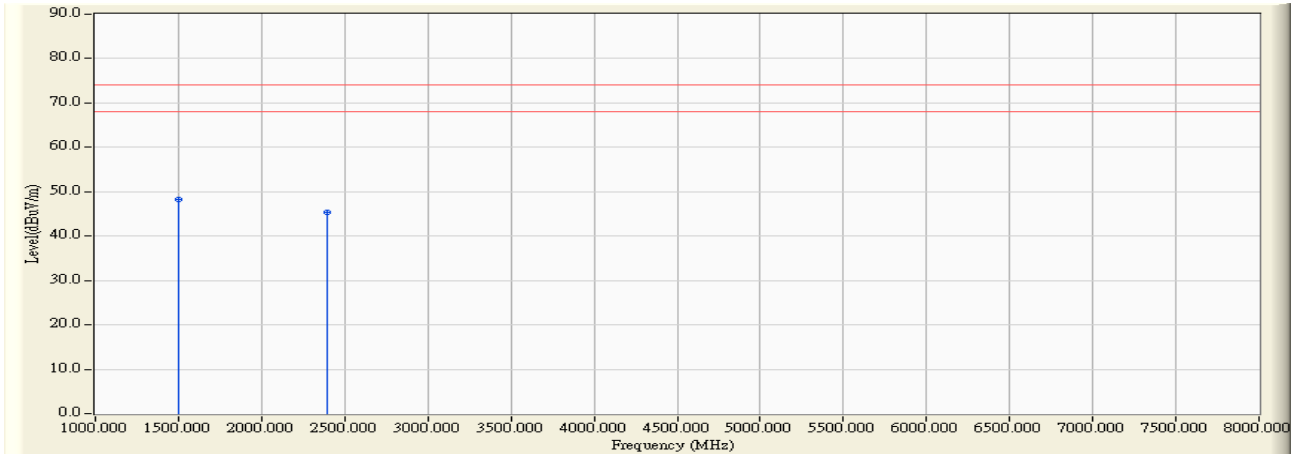

		Frequency (MHz)	Correct Factor (dB)	Reading Level (dBuV)	Measure Level (dBuV/m)	Margin (dB)	Limit (dBuV/m)	Detector Type
1	*	1505.000	-7.055	55.210	48.156	-25.844	74.000	PEAK
2		2395.000	-3.859	49.330	45.472	-28.528	74.000	PEAK

Note:

1. All Readings below 1GHz are Quasi-Peak, above are performed with peak and/or average measurements as necessary.
2. " * ", means this data is the worst emission level.
3. Measurement Level = Reading Level + Correct Factor

4.6. Test Photograph

Test Mode : Mode 1: Normal Operation

Description : Front View of Radiated Test



Test Mode : Mode 1: Normal Operation

Description : Back View of Radiated Test



Test Mode : Mode 1: Normal Operation

Description : Front View of High Frequency Radiated Test



5. Attachment

➤ EUT Photograph

(1) EUT Photo



(2) EUT Photo

