



# FCC SDoC Test Report

Issued date: May 13, 2021

Project No.: 21Q050301

**Product :** mSATA SSD

**Model :** ST250-300, SX250-300 (X=A~Z)

**Applicant :** Apacer Technology Inc.

**Address :** 1F., No.32, Zhongcheng Rd., Tucheng Dist., New Taipei City 236,  
Taiwan (R.O.C)

**Report No: WD-EF-R-210142-A0**

**According to**

**47 CFR FCC Part 15, Subpart B, Class B**  
**ICES-003: 2020 Issue 7, Class B**

**ANSI C63.4: 2014**  
**ANSI C63.4a: 2017**

**Authorized Signatory :**  / Ken Huang



**Wendell Industrial Co., Ltd**  
**Wendell EMC & RF Laboratory**

Add: 5F-1, No. 188, Baoqiao Road, Xindian District, New Taipei City 23145, Taiwan R.O.C.



## Table of Contents

<b>1</b>	<b>Certification .....</b>	<b>5</b>
1.1	Summary of Test Result.....	6
<b>2</b>	<b>Test Configuration of Equipment Under Test .....</b>	<b>7</b>
2.1	Test Facility.....	7
2.2	Measurement Uncertainty .....	8
2.2.1	Conducted Emission test.....	8
2.2.2	Radiated Emission test.....	8
<b>3</b>	<b>General Information.....</b>	<b>9</b>
3.1	Description of EUT.....	9
3.2	Description of Test Modes.....	10
3.3	EUT Operating Condition .....	10
3.4	Description of Support Unit .....	11
3.5	Configuration of System Under Test.....	11
<b>4</b>	<b>Emission Test.....</b>	<b>12</b>
4.1	Conducted Emission Measurement .....	12
4.1.1	Limit of Conducted Emission Measurement .....	12
4.1.2	Test Instrument .....	13
4.1.3	Test Procedure.....	14
4.1.4	Deviation from Test Standard .....	14
4.1.5	Test Setup.....	15
4.1.6	Test Result .....	16
4.1.7	Photographs of Test Configuration .....	18
4.2	Radiated Emission Measurement .....	19
4.2.1	Limits of Radiated Emission Measurement .....	19
4.2.2	Test Instrument .....	21
4.2.3	Test Procedure.....	22
4.2.4	Deviation from Test Standard .....	22
4.2.5	Test Setup.....	23
4.2.6	Test Result .....	24
4.2.7	Photographs of Test Configuration .....	28



### History of this test report

Report No.	Issue date	Description
WD-EF-R-210142-A0	May 13, 2021	Initial Issue

**Declaration**

This report is for your exclusive use. Any copying or replication of this report to or for any other person or entity, or use of our name or trademark, is permitted only with our prior written permission. This report sets forth our findings solely with respect to the test samples identified herein. The results set forth in this report are not indicative or representative of the quality or characteristics of the lot from which a test sample was taken or any similar or identical product unless specifically and expressly noted. Our report includes all of the tests requested by you and the results thereof based upon the information that you provided to us.



### History of supplementary report

Report No.	Issue date	Description
WD-EF-R-210142-A0	May 13, 2021	Original report

**Declaration**

This report is for your exclusive use. Any copying or replication of this report to or for any other person or entity, or use of our name or trademark, is permitted only with our prior written permission. This report sets forth our findings solely with respect to the test samples identified herein. The results set forth in this report are not indicative or representative of the quality or characteristics of the lot from which a test sample was taken or any similar or identical product unless specifically and expressly noted. Our report includes all of the tests requested by you and the results thereof based upon the information that you provided to us.



## 1 Certification

**Product:** mSATA SSD

**Brand Name:** Apacer

**Model:** ST250-300, SX250-300 (X=A~Z)

**Applicant:** Apacer Technology Inc.

**Tested:** May 05, 2021

**Standard:** 47 CFR FCC Part 15, Subpart B, Class B

ICES-003: 2020 Issue 7, Class B

ANSI C63.4: 2014

ANSI C63.4a: 2017

The above equipment (Model: ST250-300) has been tested by **Wendell EMC & RF Laboratory**, and found compliance with the requirement of the above standards. The test record, data evaluation and Equipment Under Test (EUT) configurations represented herein are true and accurate accounts of the measurements of the sample's EMC characteristics under the conditions specified in this report.

Please note that the measurement uncertainty are provided for informational purpose only and are not used in determining the Pass/Fail results.



### 1.1 Summary of Test Result

The EUT has been tested according to the following specifications:

Emission				
Standard	Test Item	Limit	Result	Remark
47 CFR FCC Part 15, Subpart B	Conducted disturbance at mains terminals	Class B	Pass	Meets the requirements
ICES-003	Radiated disturbance	Class B	Pass	Meets the requirements

**Note:** Test record contained in the referenced test report relate only to the EUT sample and test item.



## **2 Test Configuration of Equipment Under Test**

### **2.1 Test Facility**

**FCC Designation / Registration Number:**

W01: TW1117 / 831863

W08: TW1122 / 763672

**Conducted disturbance at mains terminals Test**

W01: 5F-1, No.188, Baoqiao Rd., Xindian Dist., New Taipei City 23145, Taiwan (R.O.C)

**Conducted disturbance at mains terminals and Radiated emission (9\*6\*6 Chamber) Tests**

W08: No.119, Wugong 3rd Rd., Wugu Dist., New Taipei City 248, Taiwan (R.O.C)

**ACCREDITATIONS**

The laboratories are accredited and approved by the TAF according to ISO/IEC 17025.

## 2.2 Measurement Uncertainty

The measurement instrumentation uncertainty is evaluated according to CISPR 16-4-2.

This uncertainty represents an expanded uncertainty expressed at approximately the 95% confidence level using a coverage factor of  $k=2$ .

Wendell EMC & RF Laboratory  $U_{lab}$  is less than  $U_{cispr}$ , therefore compliance or non-compliance with a disturbance limit shall be determined in the following manner.

- compliance is deemed to occur if no measured disturbance level exceeds the disturbance limit;
- non-compliance is deemed to occur if any measured disturbance level exceeds the disturbance limit.

Please note that the measurement uncertainty ( $U_{lab}$ ) is provided for informational purpose only and is not used in determining the Pass/Fail results.

### 2.2.1 Conducted Emission test

Test Site	Measurement Freq. Range	dB ( $U_{lab}$ )	Note
W01	150 kHz ~ 30 MHz	2.72	N/A
W08	150 kHz ~ 30 MHz	2.70	N/A

### 2.2.2 Radiated Emission test

Test Site	Measurement Freq. Range	Ant	dB ( $U_{lab}$ )	Note
W08	30 MHz ~ 200 MHz	V	3.68	N/A
	30 MHz ~ 200 MHz	H	2.70	N/A
	200 MHz ~ 1000 MHz	V	5.19	N/A
	200 MHz ~ 1000 MHz	H	3.26	N/A
	1 GHz ~ 6 GHz	V	4.98	N/A
	1 GHz ~ 6 GHz	H	5.07	N/A
	6 GHz ~ 18 GHz	V	5.09	N/A
	6 GHz ~ 18 GHz	H	4.99	N/A
	18 GHz ~ 40 GHz	V	4.72	N/A
	18 GHz ~ 40 GHz	H	4.72	N/A



### 3 General Information

#### 3.1 Description of EUT

<b>Product</b>	mSATA SSD
<b>Brand</b>	Apacer
<b>Model</b>	ST250-300, SX250-300 (X=A~Z)
<b>Applicant</b>	Apacer Technology Inc.
<b>Received Date</b>	May 04, 2021
<b>EUT Power Rating</b>	5Vdc (from host equipment)
<b>Model Differences</b>	The models are electrically identical, different models no. are for marketing purpose. This series model information is provided by client.
<b>Operating System</b>	N/A
<b>Data Cable Supplied</b>	N/A
<b>Accessory Device</b>	N/A
<b>I/O Port</b>	Please refer to the User's Manual

**Note:**

1. The EUT's highest operating frequency is more than 108MHz. Therefore the radiated emission is tested up to 6GHz.

### 3.2 Description of Test Modes

Test results are presented in the report as below.

Test Mode	Test Condition
<b>Conducted emission test</b>	
-	Normal mode
<b>Radiated emission 30MHz ~ 1GHz test</b>	
-	Normal mode
<b>Radiated emission above 1GHz test</b>	
-	Normal mode

### 3.3 EUT Operating Condition

- a. Inserted the EUT into PC and placed on test table.
- b. The PC run test program “BurnIN.exe” to enable all functions.
- c. The PC sent “H” message to monitor and displayed on screen.
- d. The microphone sent voice signal to PC.
- e. The PC sent voice signal to earphone.
- f. The PC sent signal to printer.
- g. The PC read/write data with EUT.

### 3.4 Description of Support Unit

The EUT has been conducted testing with other necessary accessories or support units.

Item	Equipment	Brand	Model No.	Serial No.	FCC ID	Data Cable	Power Cord	Remark
1	Desktop PC	DELL	D24M	N/A	PD93165NG	N/A	1.8m non-shielded cable	-
2	4K monitor	PHILIPS	276E8V	UKC1926000441	FCC DoC Approved	1.5m shielded HDMI cable	AC: 1.8m non-shielded cable DC: 1.4m non-shielded cable with 1 core	-
3	Keyboard	DELL	KB216t	CN-0W33XP-L0 300-7C1-15UP	FCC DoC Approved	1.5m non-shielded cable	N/A	-
4	Mouse	DELL	MS116	CN-0DV0RH-L0 300-7C1-15UP	FCC DoC Approved	1.5m non-shielded cable	N/A	-
5	Earphone & microphone	E-books	E-EPA057	N/A	N/A	1.4m non-shielded cable	N/A	-
6	Printer	HP	SNPRH-1504	CN738282V9	FCC DoC Approved	1.4m shielded USB cable	AC: 1.7m non-shielded cable	-

**Note:** 1. The core(s) is(are) originally attached to the cable(s).

### 3.5 Configuration of System Under Test

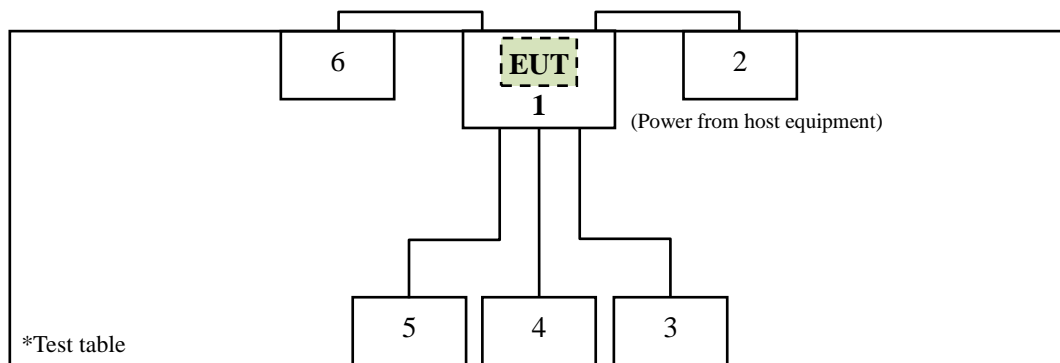



## 4 Emission Test

### 4.1 Conducted Emission Measurement

#### 4.1.1 Limit of Conducted Emission Measurement

Frequency (MHz)	Class A (dB $\mu$ V)		Class B (dB $\mu$ V)	
	Quasi-peak (dB $\mu$ V)	Average (dB $\mu$ V)	Quasi-peak (dB $\mu$ V)	Average (dB $\mu$ V)
0.15 - 0.5	79	66	66 to 56	56 to 46
0.5 - 5	73	60	56	46
5 - 30	73	60	60	50

- Note:**
1. The lower limit shall apply at the transition frequencies.
  2. The limit decreases in line with the logarithm of the frequency in the range of 0.15 to 0.50 MHz.
  3. Detector function in the form: PK = Peak, QP = Quasi Peak, AV = Average
  4. The test result calculated as following:  
Measurement Value = Reading Level + Correct Factor  
Correction Factor = Insertion loss of LISN + Cable loss + Transient Limiter (If use)  
Margin Level = Measurement Value – Limit Value



#### 4.1.2 Test Instrument

Test Site: W01-CE					
Item	Equipment	Manufacturer	Model	Meter No.	Calibration Date
1	TWO-LINE V-NETWORK	R&S	ENV216	CT-1-025-1	Apr. 29, 2020
2	Pulse limiter	R&S®	ESH3-Z2	CT-2-015	Apr. 27, 2020
3	EMI Test Receiver	R&S	ESCI	CT-1-024	Apr. 29, 2020
4	V-LISN	SCHWARZBECK	NSLK8127	CT-1-104-1	Apr. 29, 2020
5	Test Cable	Marvelous Microwave Inc	200200.400LL .500A	CT-10-048-1	Apr. 27, 2020
6	50ohm Termination	N/A	N/A	CT-1-065-1	Apr. 28, 2020
7	Measurement Software	EZ-EMC	Ver: EMC-CON 3A1	CT-3-012	No calibration request

**Note:** 1. The calibration interval of the above test instruments is 12 months.

Test Site: W08-CE					
Item	Equipment	Manufacturer	Model	Meter No.	Calibration Date
1	TWO-LINE V-NETWORK LISN	R&S®	ENV216	CT-1-025-2	May 27, 2020
2	Test Cable	EMCI	EMCCFD300-BM-BM-5000	CT-1-107-2	May 25, 2020
3	EMI Test Receiver	R&S	ESR3	CT-1-103	May 21, 2020
4	LISN	SCHWARZBECK	NSLK 8127RC	CT-1-104-1RC	May 27, 2020
5	Transient Limiter	EM Electronics Corporation	EM-7600	CT-1-026	May 25, 2020
6	50ohm Termination	HUBER+SUHNER	N/A	CT-1-109-1	May 26, 2020
7	Measurement Software	EZ-EMC	Ver: EMC-CON 3A1	CT-3-012	No calibration request

**Note:** 1. The calibration interval of the above test instruments is 12 months.



### **4.1.3 Test Procedure**

- a. The table-top EUT was placed 0.8 meter height wooden table from the horizontal ground plane with EUT being connected to power source through a line impedance stabilization network (LISN). The LISN at least be 80 cm from nearest chassis of EUT. The floor-standing EUT and all cables shall be insulated from the ground plane by up to 12 mm of insulating material if required.
- b. The line impedance stabilization network (LISN) provides 50 ohm/50uH of coupling impedance for the measuring instrument. All other support equipments powered from additional LISN(s).
- c. Interrelating cables that hang closer than 40 cm to the ground plane shall be folded back and forth in the center forming a bundle. All I/O cables were positioned to simulate typical usage.
- d. All I/O cables that are not connected to a peripheral shall be bundle in the center. The end of the cable may be terminated, if required, using the correct terminating impedance. The overall length shall not exceed 1 m.
- e. The EMI test receiver connected to LISN powering the EUT. The actual test configuration, please refer to EUT test photos.
- f. The receiver scanned from 150kHz to 30MHz for emissions in each of test modes. A scan was taken on both power lines, Line and Neutral, recording at least six highest emissions.
- g. The EUT and cable configuration of the above highest emission levels were recorded. The test data of the worst case was recorded.

### **4.1.4 Deviation from Test Standard**

No deviation

### 4.1.5 Test Setup

#### < Table-Top equipment >

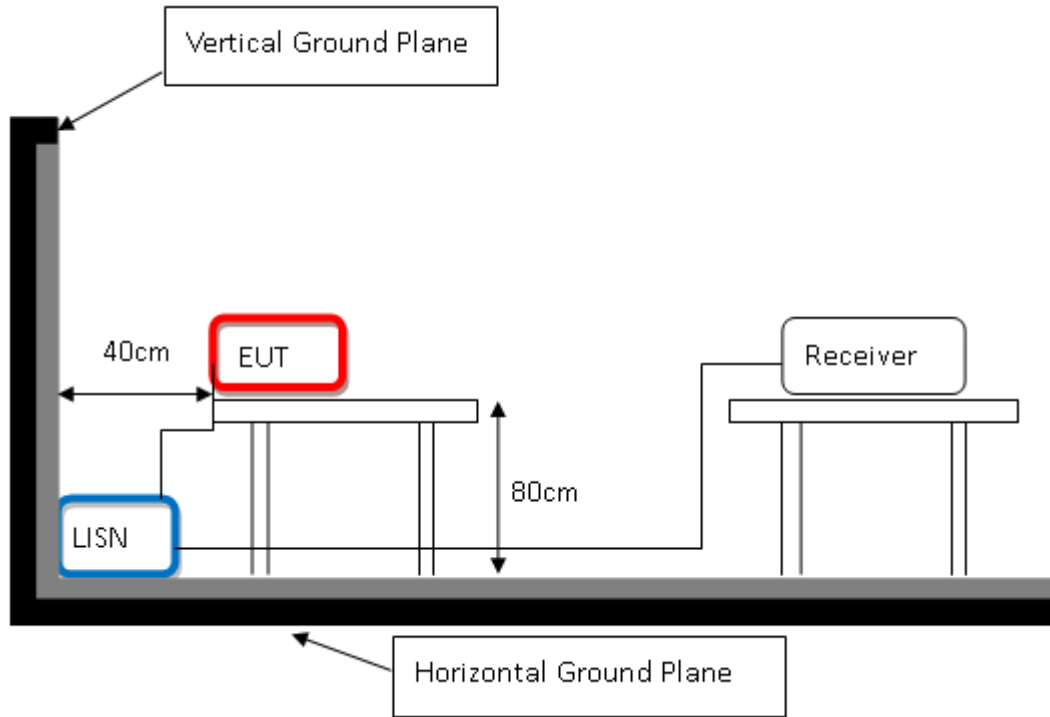

#### < Floor-Standing equipment >

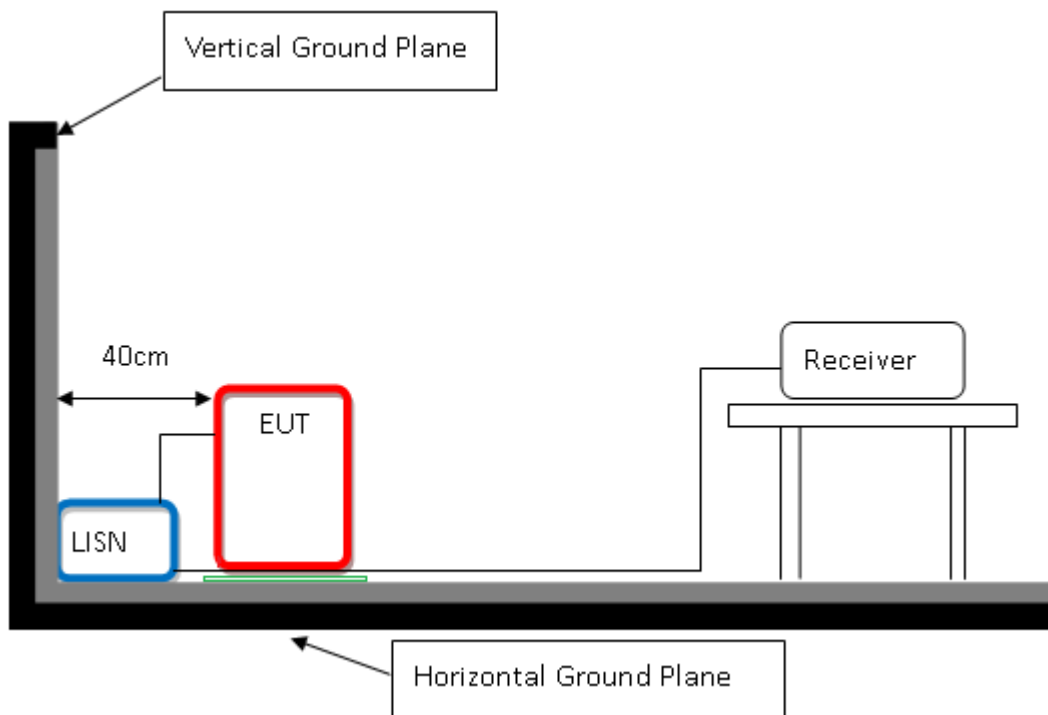

**Note:** Please refer to 4.1.7 for the actual test configuration.



### 4.1.6 Test Result

<b>Test Voltage</b>	120Vac, 60Hz	<b>Frequency Range</b>	0.15-30 MHz
<b>Environmental Conditions</b>	29°C, 38% RH	<b>6dB Bandwidth</b>	9 kHz
<b>Test Date</b>	2021/05/05	<b>Phase</b>	L
<b>Tested by</b>	Rod Yu	<b>Test Site</b>	W08

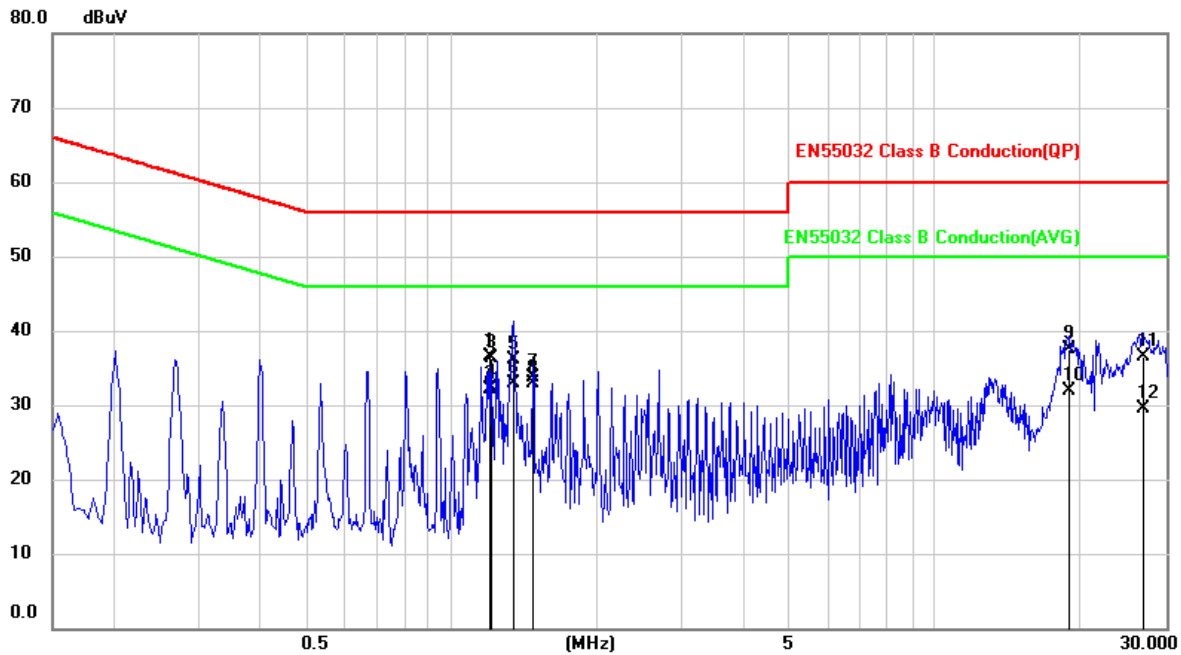

No.	Frequency (MHz)	Reading Level (dBμV)	Correct Factor (dB)	Measurement (dBμV)	Limit (dBμV)	Margin (dB)	Detector
1	1.2090	26.74	9.77	36.51	56.00	-19.49	QP
2	1.2090	22.38	9.77	32.15	46.00	-13.85	AVG
3	1.2102	26.46	9.77	36.23	56.00	-19.77	QP
4	1.2102	22.59	9.77	32.36	46.00	-13.64	AVG
5	1.3431	26.31	9.78	36.09	56.00	-19.91	QP
6	1.3431	23.08	9.78	32.86	46.00	-13.14	AVG
7	1.4792	23.99	9.79	33.78	56.00	-22.22	QP
8	1.4792	23.13	9.79	32.92	46.00	-13.08	AVG
9	18.9556	27.56	9.97	37.53	60.00	-22.47	QP
10	18.9556	21.87	9.97	31.84	50.00	-18.16	AVG
11	26.8801	26.50	10.00	36.50	60.00	-23.50	QP
12	26.8801	19.50	10.00	29.50	50.00	-20.50	AVG

**Remark:** 1. QP = Quasi Peak, AVG = Average  
 2. Correction Factor = Insertion loss of LISN + Cable loss + Transient Limiter (If use)  
 3. Measurement Value = Reading Level + Correct Factor  
 4. Margin Level = Measurement Value - Limit Value



<b>Test Voltage</b>	120Vac, 60Hz	<b>Frequency Range</b>	0.15-30 MHz
<b>Environmental Conditions</b>	29°C, 38% RH	<b>6dB Bandwidth</b>	9 kHz
<b>Test Date</b>	2021/05/05	<b>Phase</b>	N
<b>Tested by</b>	Rod Yu	<b>Test Site</b>	W08

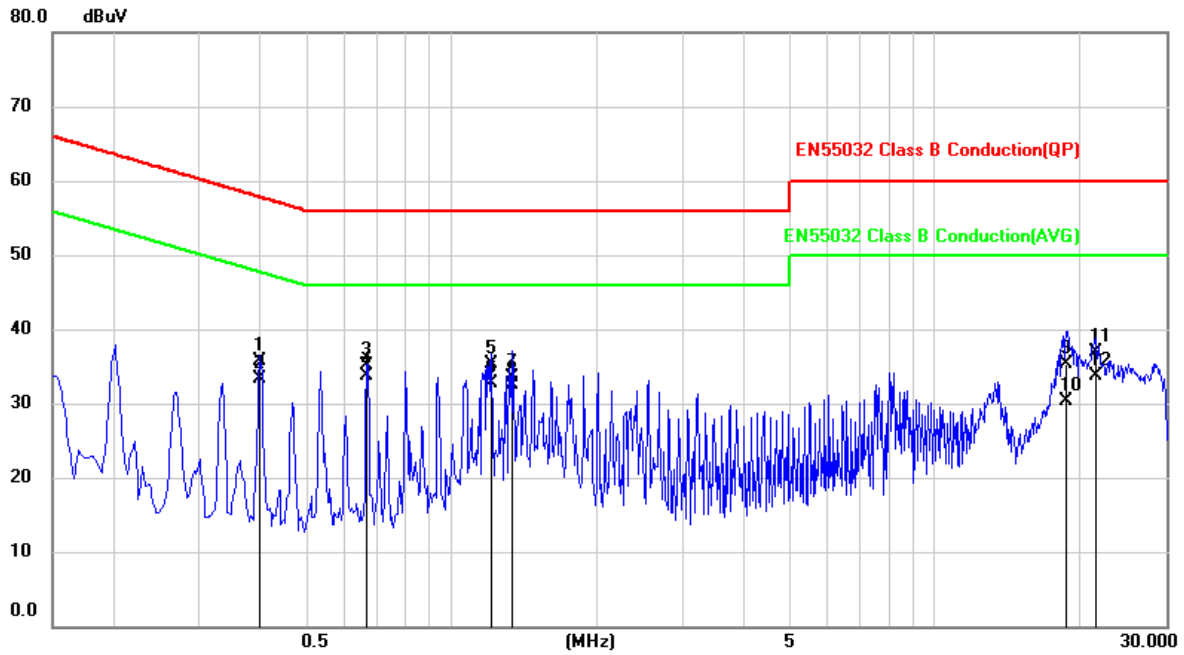

No.	Frequency (MHz)	Reading Level (dB $\mu$ V)	Correct Factor (dB)	Measurement (dB $\mu$ V)	Limit (dB $\mu$ V)	Margin (dB)	Detector
1	0.4034	25.85	9.76	35.61	57.78	-22.17	QP
2	0.4034	23.54	9.76	33.30	47.78	-14.48	AVG
3	0.6716	25.42	9.76	35.18	56.00	-20.82	QP
4	0.6716	23.99	9.76	33.75	46.00	-12.25	AVG
5	1.2081	25.54	9.77	35.31	56.00	-20.69	QP
6	1.2081	23.00	9.77	32.77	46.00	-13.23	AVG
7	1.3439	23.65	9.78	33.43	56.00	-22.57	QP
8	1.3439	22.72	9.78	32.50	46.00	-13.50	AVG
9	18.6846	25.37	9.95	35.32	60.00	-24.68	QP
10	18.6846	20.45	9.95	30.40	50.00	-19.60	AVG
11	21.4521	26.97	9.98	36.95	60.00	-23.05	QP
12	21.4521	23.75	9.98	33.73	50.00	-16.27	AVG

**Remark:** 1. QP = Quasi Peak, AVG = Average  
 2. Correction Factor = Insertion loss of LISN + Cable loss + Transient Limiter (If use)  
 3. Measurement Value = Reading Level + Correct Factor  
 4. Margin Level = Measurement Value - Limit Value

### 4.1.7 Photographs of Test Configuration

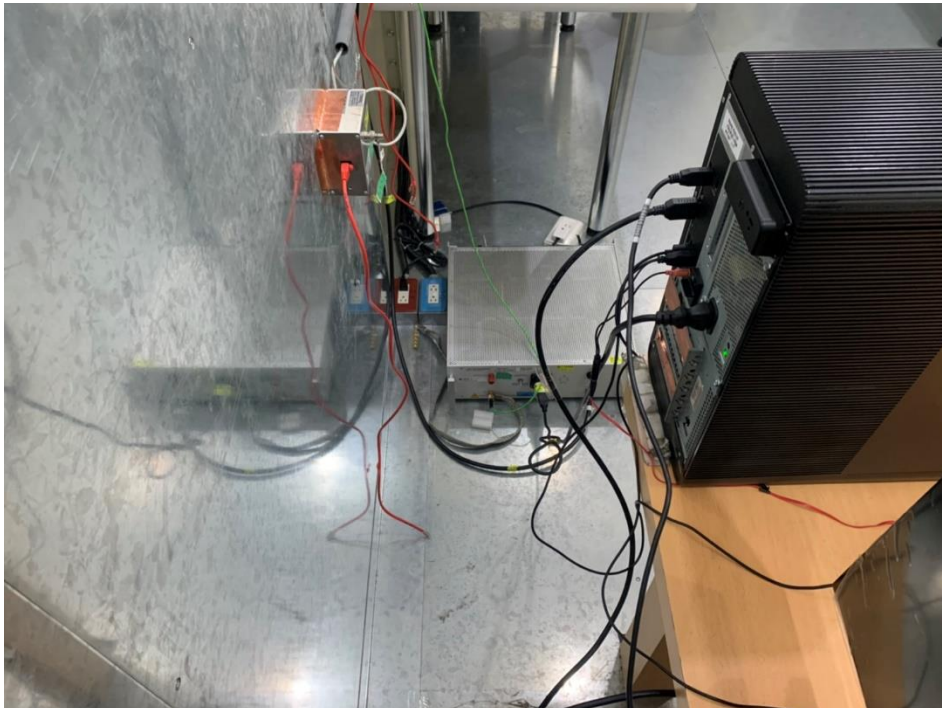



## 4.2 Radiated Emission Measurement

### 4.2.1 Limits of Radiated Emission Measurement

Radiated Frequency range 30 MHz to 1000 MHz

FCC 15B Radiated Emissions Limits				
Frequency range (MHz)	Class A (3m) Quasi-peak (dB $\mu$ V/m)	Class A (10m) Quasi-peak (dB $\mu$ V/m)	Class B (3m) Quasi-peak (dB $\mu$ V/m)	Class B (10m) Quasi-peak (dB $\mu$ V/m)
30 - 88	49.5	39.1	40	29.5
88 - 216	54	43.5	43.5	33.1
216 - 230	56.9	46.4	46	35.6
230 - 960				
960 - 1000	60	49.5	54	43.5

ICES-003 Radiated Emissions Limits				
Frequency range (MHz)	Class A (3m) Quasi-peak (dB $\mu$ V/m)	Class A (10m) Quasi-peak (dB $\mu$ V/m)	Class B (3m) Quasi-peak (dB $\mu$ V/m)	Class B (10m) Quasi-peak (dB $\mu$ V/m)
30 - 88	50	40	40	30
88 - 216	54	43.5	43.5	33.1
216 - 230	56.9	46.4	46	35.6
230 - 960	57	47	47	37
960 - 1000	60	49.5	54	43.5

- Note:**
1. The lower limit shall apply at the transition frequency.
  2. Detector function in the form: PK = Peak, QP = Quasi Peak, AV = Average
  3. The test result calculated as following:  
 Measurement Value = Reading Level + Correct Factor  
 Correction Factor = Antenna factor + Cable loss (Antenna to preamplifier) - preamplifier Gain  
 + Cable loss (preamplifier to receiver)  
 Margin Level = Measurement Value - Limit Value

**Radiated Frequency range above 1 GHz**

<b>FCC 15B / ICES-003 Radiated Emissions Limits</b>				
<b>Frequency range (GHz)</b>	<b>Class A (3m) (dB<math>\mu</math>V/m)</b>		<b>Class B (3m) (dB<math>\mu</math>V/m)</b>	
	<b>Peak</b>	<b>Average</b>	<b>Peak</b>	<b>Average</b>
1 - 40	80	60	74	54

**Note:** 1. The lower limit shall apply at the transition frequency.

2. Detector function in the form: PK = Peak, QP = Quasi Peak, AV = Average

3. The test result calculated as following:

Measurement Value = Reading Level + Correct Factor

Correction Factor = Antenna factor + Cable loss (Antenna to preamplifier) - preamplifier Gain  
+ Cable loss (preamplifier to receiver)

Margin Level = Measurement Value - Limit Value

**Frequency Range (For unintentional radiators)**

<b>Highest frequency generated or used in the device or on which the device operates or tunes (MHz)</b>	<b>Upper frequency of measurement range (MHz)</b>
Below 1.705	30
1.705-108	1000
108-500	2000
500-1000	5000
Above 1000	5th harmonic of the highest frequency or 40GHz, whichever is lower



## 4.2.2 Test Instrument

Test Site: W08-966					
Item	Equipment	Manufacturer	Model	Meter No.	Calibration Date
1	Horn Antenna	Schwarzbeck	BBHA 9120D	CT-9-031	Jul. 28, 2020
2	Horn Antenna	Schwarzbeck	BBHA 9170	CT-9-032	Dec. 03, 2020
3	TRILOG Broadband Antenna with 5 dB Attenuator	Schwarzbeck	VULB 9168 & FAT-NM5NF5T3G 2W5	CT-1-002-1	Jul. 29, 2020
4	EXA Signal Analyzer	Keysight	N9010A	CT-1-093	Apr. 21, 2021
5	EMI Test Receiver	Keysight	N9038A	CT-9-007	Jul. 28, 2020
6	Preamplifier	EM	EM 330	CT-9-024	Jul. 30, 2020
7	Preamplifier	JPT	JPA0118-55-303K	CT-1-139	Apr. 21, 2021
8	Preamplifier	EMCI	EMC051845SE	CT-9-012	Sep. 04, 2020
9	Preamplifier	EMCI	EMC184045SE	CT-9-013	Sep. 04, 2020
10	Test Cable	EMCI	EMCCFD400-NM-NM-1000	CT-1-132	Jul. 29, 2020
11	Test Cable	PEWC	CFD400NL-LW-N M-NM-3000	CT-1-141	Jul. 30, 2020
12	Test Cable	EMCI	EMCCFD400-NM-NM-15000	CT-1-133	Jul. 30, 2020
13	Test Cable	EMCI	EMC104-SM-35M-600	CT-1-134	Jul. 30, 2020
14	Test Cable	EMCI	EMC104-SM-35M-15000	CT-1-135	Jul. 30, 2020
15	Test Cable	EMCI	EMC102-KM-KM-600	CT-1-136	Jul. 30, 2020
16	Test Cable	MVE	140140.LL404.700	CT-9-066	Apr. 21, 2021
17	Measurement Software	EZ-EMC	Ver : FA-03A2 RE	CT-3-012	No calibration request

**Note:** 1. The calibration interval of the above test instruments is 12 months.



### 4.2.3 Test Procedure

- a. The table-top EUT was placed on the top of a turntable 0.8 meters above the ground at 3 m 966 chamber. The floor-standing EUT and all cables shall be insulated from the ground plane by up to 12 mm of insulating material if required. The table was rotated 360 degrees to determine the position of the high radiation emissions.
- b. The height of the test antenna shall vary between 1 m to 4 m. Both vertical and horizontal polarizations of the antenna were set to make the measurement.
- c. The EUT was set up as per the test configuration to simulate typical usage per the user's manual. All I/O cables were positioned to simulate typical usage. The actual test configuration, please refer to EUT test photos.
- d. The initial step in collecting radiated emission data is a Spectrum Mode scanning the measurement frequency range.

#### **Below 1GHz:**

Reading in which marked as QP or Peak means measurements by using Spectrum Mode with detector RBW=120kHz.

If the Spectrum Mode measured peak value compliance with and lower than Quasi Peak Limit, the EUT shall be deemed to meet QP Limits.

#### **Above 1GHz:**

Reading in which marked as Peak & AVG means measurements by using Spectrum Mode with setting in RBW=1MHz.

If the Spectrum Mode measured value compliance with the Peak Limits and lower than AVG Limits, the EUT shall be deemed to meet both Peak and AVG Limits.

- e. Emission frequency and amplitude were recorded, recording at least six highest emissions. The EUT and cable configuration of the above highest emission levels were recorded. The test data of the worst case was recorded.

### 4.2.4 Deviation from Test Standard

No deviation

## 4.2.5 Test Setup

< Radiated Emissions Frequency: 30 MHz to 1000 MHz >

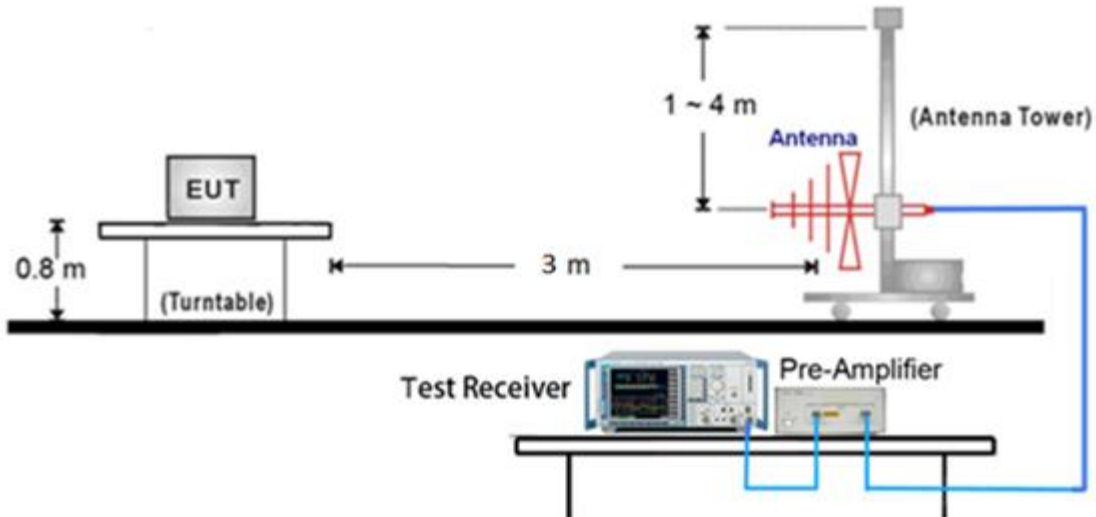

< Radiated Emissions Frequency: above 1GHz >

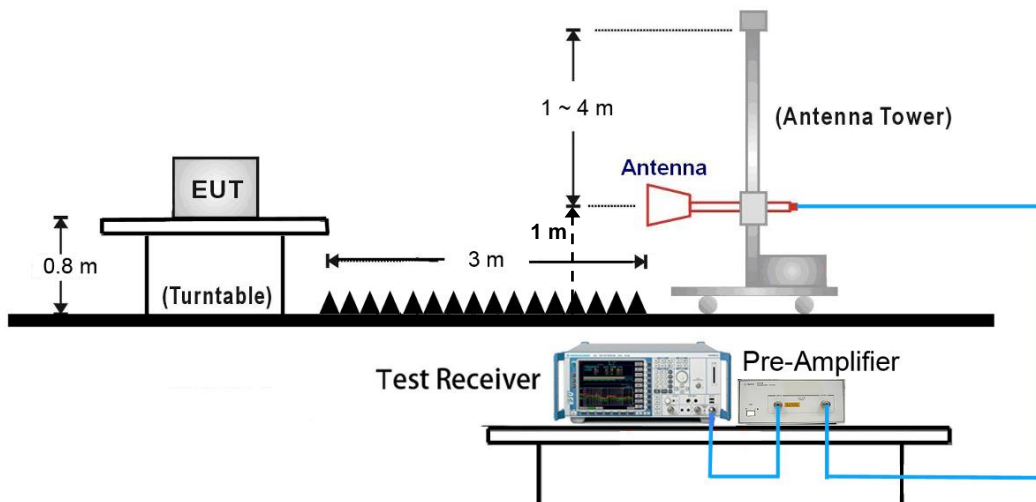

### Note:

- (1) Please refer to the 4.2.7 for the actual test configuration.
- (2) The formula of measured value as:  $\text{Test Result} = \text{Reading} + \text{Correction Factor}$
- (3) Detector function in the form: PK = Peak, QP = Quasi Peak, AV = Average
- (4) The test result calculated as following:  
 $\text{Measurement Value} = \text{Reading Level} + \text{Correct Factor}$   
 $\text{Correct Factor} = \text{Antenna Factor} + \text{Cable Loss} - \text{Amplifier Gain (if use)}$   
 $\text{Margin Level} = \text{Measurement Value} - \text{Limit Value}$



### 4.2.6 Test Result

<b>Test Voltage</b>	120Vac, 60Hz	<b>Frequency Range</b>	30 – 1000 MHz
<b>Environmental Conditions</b>	25°C, 50% RH	<b>6dB Bandwidth</b>	120 kHz
<b>Test Date</b>	2021/05/05	<b>Test Distance</b>	3m
<b>Tested by</b>	Karwin Kao	<b>Polarization</b>	Vertical
<b>Test Site</b>	W08		

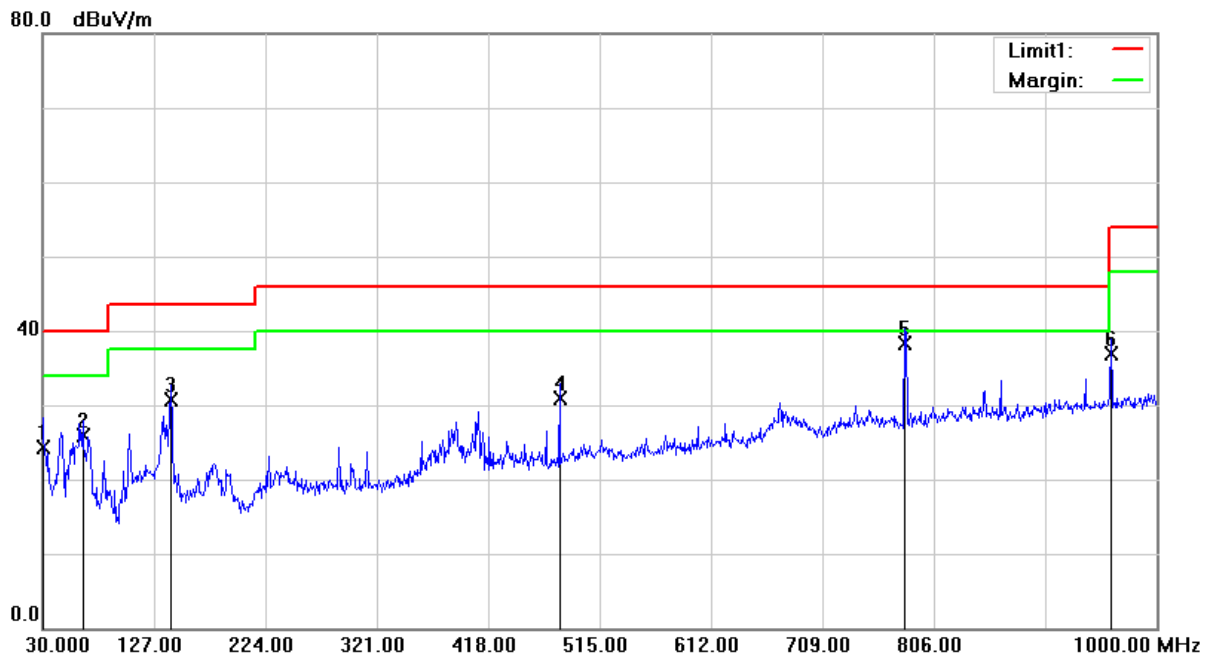

No.	Frequency (MHz)	Reading Level (dBμV)	Correct Factor (dB/m)	Measurement (dBμV/m)	Limit (dBμV/m)	Margin (dB)	Table Degree (degree)	Antenna Height (cm)	Detector
1	30.0000	34.57	-10.18	24.39	40.00	-15.61	35	100	QP
2	64.9200	37.19	-11.22	25.97	40.00	-14.03	360	102	QP
3	141.5500	40.10	-9.45	30.65	43.50	-12.85	360	173	QP
4	480.0800	35.31	-4.37	30.94	46.00	-15.06	182	100	QP
5	780.7800	37.22	1.03	38.25	46.00	-7.75	182	100	QP
6	960.2300	32.81	4.16	36.97	54.00	-17.03	161	200	QP

**Remark:** 1. QP = Quasi Peak  
 2. Correction Factor = Antenna factor + Cable loss (Antenna to preamplifier) - preamplifier Gain + Cable loss (preamplifier to receiver)  
 3. Measurement Value = Reading Level + Correct Factor  
 4. Margin Level = Measurement Value - Limit Value



<b>Test Voltage</b>	120Vac, 60Hz	<b>Frequency Range</b>	30 – 1000 MHz
<b>Environmental Conditions</b>	25°C, 50% RH	<b>6dB Bandwidth</b>	120 kHz
<b>Test Date</b>	2021/05/05	<b>Test Distance</b>	3m
<b>Tested by</b>	Karwin Kao	<b>Polarization</b>	Horizontal
<b>Test Site</b>	W08		

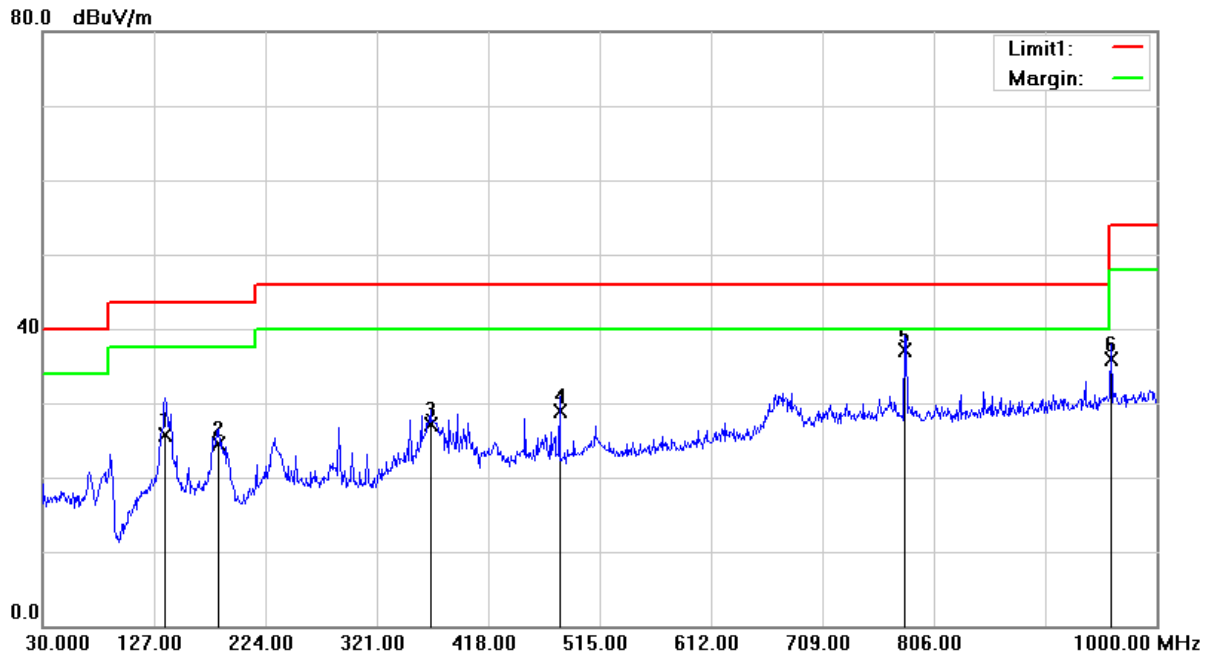

No.	Frequency (MHz)	Reading Level (dBμV)	Correct Factor (dB/m)	Measurement (dBμV/m)	Limit (dBμV/m)	Margin (dB)	Table Degree (degree)	Antenna Height (cm)	Detector
1	136.7000	35.41	-9.68	25.73	43.50	-17.77	98	200	QP
2	183.2600	34.10	-9.69	24.41	43.50	-19.09	204	100	QP
3	367.5600	33.80	-6.76	27.04	46.00	-18.96	274	100	QP
4	480.0800	33.20	-4.37	28.83	46.00	-17.17	15	200	QP
5	780.7800	36.16	1.03	37.19	46.00	-8.81	121	100	QP
6	960.2300	31.80	4.16	35.96	54.00	-18.04	141	100	QP

**Remark:**

1. QP = Quasi Peak
2. Correction Factor = Antenna factor + Cable loss (Antenna to preamplifier ) - preamplifier Gain + Cable loss (preamplifier to receiver )
3. Measurement Value = Reading Level + Correct Factor
4. Margin Level = Measurement Value - Limit Value



<b>Test Voltage</b>	120Vac, 60Hz	<b>Frequency Range</b>	1 – 6GHz
<b>Environmental Conditions</b>	24°C, 57% RH	<b>6dB Bandwidth</b>	1MHz
<b>Test Date</b>	2021/05/05	<b>Test Distance</b>	3m
<b>Tested by</b>	Karwin Kao	<b>Polarization</b>	Vertical
<b>Test Site</b>	W08		

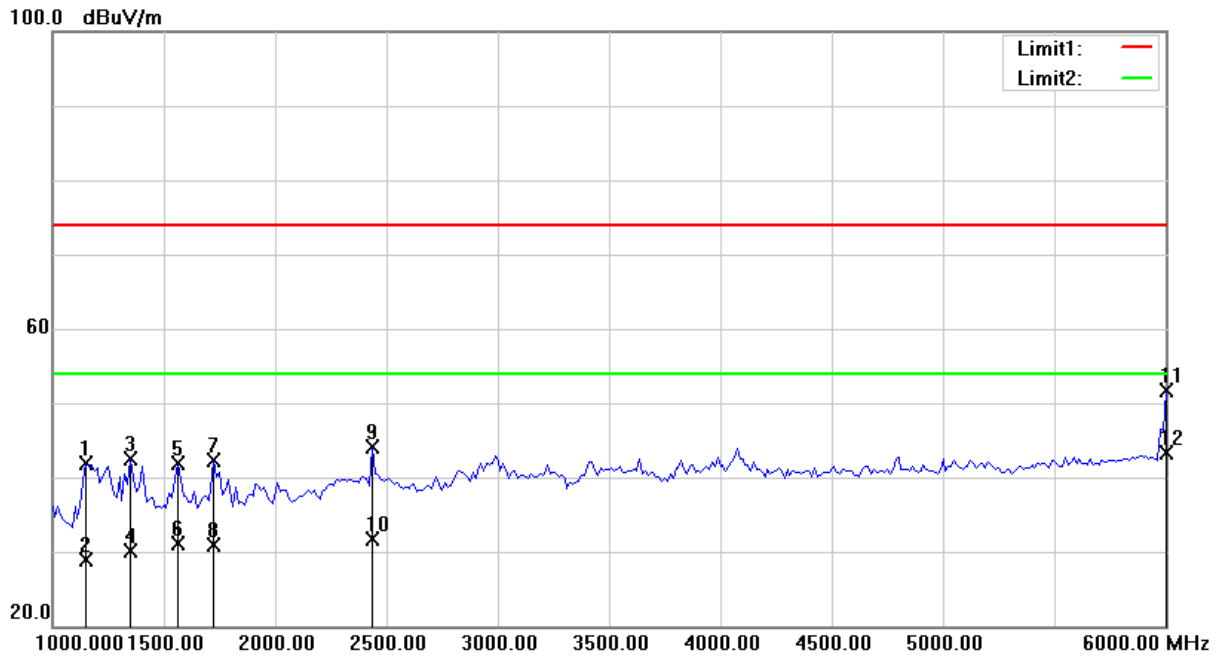

No.	Frequency (MHz)	Reading Level (dBμV)	Correct Factor (dB/m)	Measurement (dBμV/m)	Limit (dBμV/m)	Margin (dB)	Table Degree (degree)	Antenna Height (cm)	Detector
1	1150.000	55.80	-13.93	41.87	74.00	-32.13	218	100	peak
2	1150.000	42.85	-13.93	28.92	54.00	-25.08	218	100	AVG
3	1350.000	55.23	-12.78	42.45	74.00	-31.55	288	100	peak
4	1350.000	42.91	-12.78	30.13	54.00	-23.87	288	100	AVG
5	1562.500	54.58	-12.74	41.84	74.00	-32.16	181	100	peak
6	1562.500	43.88	-12.74	31.14	54.00	-22.86	181	100	AVG
7	1725.000	54.86	-12.56	42.30	74.00	-31.70	178	100	peak
8	1725.000	43.37	-12.56	30.81	54.00	-23.19	178	100	AVG
9	2437.500	53.32	-9.25	44.07	74.00	-29.93	210	200	peak
10	2437.500	40.87	-9.25	31.62	54.00	-22.38	210	200	AVG
11	6000.000	51.32	0.36	51.68	74.00	-22.32	215	100	peak
12	6000.000	42.87	0.36	43.23	54.00	-10.77	215	100	AVG

**Remark:** 1. peak = Peak, AVG = Average  
 2. Correction Factor = Antenna factor + Cable loss (Antenna to preamplifier ) - preamplifier Gain + Cable loss (preamplifier to receiver )  
 3. Measurement Value = Reading Level + Correct Factor  
 4. Margin Level = Measurement Value - Limit Value



<b>Test Voltage</b>	120Vac, 60Hz	<b>Frequency Range</b>	1 – 6GHz
<b>Environmental Conditions</b>	24°C, 57% RH	<b>6dB Bandwidth</b>	1MHz
<b>Test Date</b>	2021/05/05	<b>Test Distance</b>	3m
<b>Tested by</b>	Karwin Kao	<b>Polarization</b>	Horizontal
<b>Test Site</b>	W08		

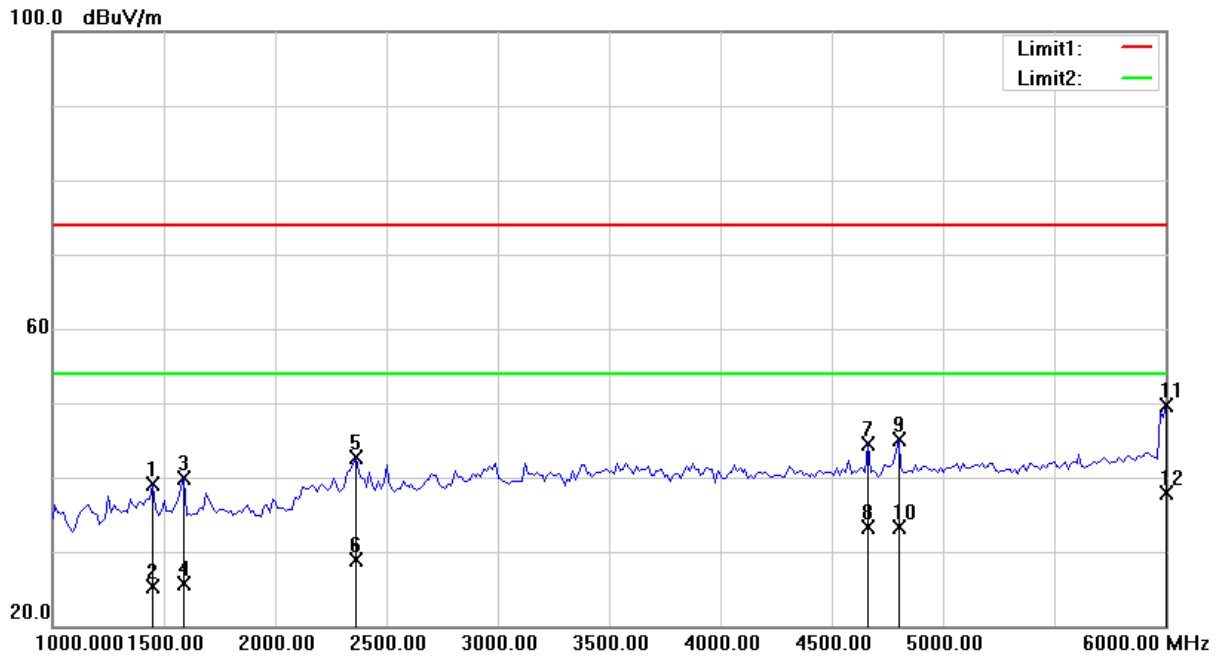

No.	Frequency (MHz)	Reading Level (dBμV)	Correct Factor (dB/m)	Measurement (dBμV/m)	Limit (dBμV/m)	Margin (dB)	Table Degree (degree)	Antenna Height (cm)	Detector
1	1450.000	51.49	-12.31	39.18	74.00	-34.82	93	200	peak
2	1450.000	37.53	-12.31	25.22	54.00	-28.78	93	200	AVG
3	1587.500	52.58	-12.76	39.82	74.00	-34.18	360	166	peak
4	1587.500	38.49	-12.76	25.73	54.00	-28.27	360	166	AVG
5	2362.500	51.61	-8.95	42.66	74.00	-31.34	360	118	peak
6	2362.500	37.87	-8.95	28.92	54.00	-25.08	360	118	AVG
7	4662.500	47.24	-2.65	44.59	74.00	-29.41	53	100	peak
8	4662.500	35.88	-2.65	33.23	54.00	-20.77	53	100	AVG
9	4800.000	47.65	-2.58	45.07	74.00	-28.93	270	100	peak
10	4800.000	35.91	-2.58	33.33	54.00	-20.67	270	100	AVG
11	6000.000	49.42	0.36	49.78	74.00	-24.22	179	100	peak
12	6000.000	37.48	0.36	37.84	54.00	-16.16	179	100	AVG

**Remark:** 1. peak = Peak, AVG = Average  
 2. Correction Factor = Antenna factor + Cable loss (Antenna to preamplifier) - preamplifier Gain + Cable loss (preamplifier to receiver)  
 3. Measurement Value = Reading Level + Correct Factor  
 4. Margin Level = Measurement Value - Limit Value

## 4.2.7 Photographs of Test Configuration

### Radiated Emission Test (30MHz~1GHz)



**Radiated Emission Test (Above 1GHz)**



< End Page >