



EMC TEST REPORT

Product : SATA Flash Drive
Model Name : SH250-25, SV250-25, SX250-25(X=A~Z)
Applicant : APACER TECHNOLOGY INC
Address : 1F., No.32, Zhongcheng Rd., Tucheng Dist.,
New Taipei City 236, Taiwan
Manufacturer : APACER TECHNOLOGY INC
Address : 1F., No.32, Zhongcheng Rd., Tucheng Dist.,
New Taipei City 236, Taiwan
Standard : EN 55032:2015+A11:2020 Class B
EN IEC 61000-3-2:2019
EN 61000-3-3:2013+A1:2019
EN 55035:2017+A11:2020
BS EN 55032:2015+A11:2020 Class B
BS EN IEC 61000-3-2:2019
BS EN 61000-3-3:2013+A1:2019
BS EN 55035:2017+A11:2020
CISPR32:2015 Class B

The product was received on Aug. 06, 2021, and testing was started from Aug. 06, 2021 and completed on Aug. 21, 2021. We, SPORTON INTERNATIONAL INC. Hsinhua Laboratory, would like to declare that the tested sample has been evaluated in accordance with the procedures given in above standards and shown compliance with the applicable technical standards.

The test results in this variant report apply exclusively to the tested model / sample. Without written approval of SPORTON INTERNATIONAL INC. Hsinhua Laboratory, the test report shall not be reproduced except in full.

Approved by: William Li

SPORTON INTERNATIONAL INC. Hsinhua Laboratory
No.52, Huaya 1st Rd., Guishan Dist., Taoyuan City 333411, Taiwan (R.O.C.)



Table of Contents

History of this test report.....	3
Summary of Test Result.....	4
1. General Description of Equipment under Test.....	6
1.1. Basic Description of Equipment under Test	6
1.2. Feature of Equipment under Test	6
1.3. Table for Multiple Listing	6
1.4. Table for Existing Change	6
2. Test Configuration of Equipment under Test	7
2.1. Details of EUT Test Modes.....	7
2.2. Description of Test System.....	8
2.3. Connection Diagram of Test System	9
2.4. Details of EUT Test Setup	11
3. General Information of Test.....	12
3.1. Test Facilities	12
3.2. Test Standards.....	13
3.3. Test Voltage/Frequencies	13
3.4. Test Distance and Frequency Range Investigated	13
3.5. Operating Condition	13
4. Emissions Measurement	14
4.1. Conducted Emissions at Powerline	14
4.2. Radiated Emission below 1GHz	20
4.3. Radiated Emission above 1GHz.....	28
4.4. Harmonic Current Emissions Measurement	33
4.5. Voltage Fluctuations and Flicker Measurement	35
5. Immunity Measurement	37
5.1. General performance criteria	37
5.2. Electrostatic Discharge (ESD)	38
5.3. Radio Frequency Electromagnetic Field (RS).....	44
5.4. Power Frequency Magnetic Field (PFMF)	47
6. Uncertainty of Test Site	50
6.1. Emission Test Measurement Uncertainty	50
7. List of Measuring Equipment Used	51
Appendix A. Test Photos	
Photographs of EUT v01	



Summary of Test Result

Report Clause	Ref Std. Clause	Test reference standard	Test Items	Result (PASS/FAIL)	Remark
Emission Tests and Conformance Test Specifications					
4.1	A.3	EN 55032:2015+A11:2020 Class B BS EN 55032:2015+A11:2020 Class B	Conducted Emission	PASS	Under limit 10.52 dB at 10.13 MHz
-	A.3		Conducted Emissions of asymmetric mode	Not Applicable	Note 1
4.2	A.2		Radiated Emissions below 1GHz	PASS	Under limit 6.85 dB at 39.170 MHz
4.3	A.2		Radiated Emissions above 1GHz	PASS	Under limit 15.02 dB at 2.145 GHz
4.4	6.2	EN IEC 61000-3-2:2019 BS EN IEC 61000-3-2:2019	Harmonic Current Emissions	PASS	-
4.5	6.1	EN 61000-3-3:2013+A1:2019 BS EN 61000-3-3:2013+A1:2019	Voltage Fluctuations and Flicker	PASS	-
Note 1: There are no wired network ports on the EUT.					
Note 2: From Sporton Project No.:EC180201.					

Report Clause	Ref Std. Clause	Test reference standard	Test Items	Result (PASS/FAIL)	Remark	
Immunity Tests and Conformance Test Specifications - EN 55035:2017+A11:2020, BS EN 55035:2017+A11:2020						
5.2	4.2.1	IEC 61000-4-2 Edition 2.0 2008-12	ESD	PASS	-	
5.3	4.2.2.2	IEC 61000-4-3 Edition 3.2 2010-04	RS	PASS	-	
-	4.2.4	IEC 61000-4-4 Edition 3.0 2012-04	EFT/B	Power Port	Not Applicable	Note 1
				Analogue/digital data ports	Not Applicable	Note 2
-	4.2.5	IEC 61000-4-5 Edition 3.1 2017-08	Surges	Power Port	Not Applicable	Note 1
				Analogue/digital data ports	Not Applicable	Note 2
-	4.2.2.3	IEC 61000-4-6 Edition 4.0 2013-10	CS	Power Port	Not Applicable	Note 1
				Analogue/digital data ports	Not Applicable	Note 2
5.4	4.2.3	IEC 61000-4-8 Edition 2.0 2009-09	Power Frequency Magnetic Fields	PASS	-	
-	4.2.6	IEC 61000-4-11 Edition 2.1 2017-05	Voltage dips	Not Applicable	Note 1	
			Voltage interruptions	Not Applicable	Note 1	
According to the applicant's requirements, the version of the normative reference used in this test report is specified by the applicant.						
Note 1: It was supplied power by host system for EUT; It's not necessary to apply to EFT, Surge, CS and DIP test.						
Note 2: According to the manufacturer's specification, maximum cable length is less than 3m in length, the EUT is not an external device.						
Note 3: From Sporton Project No.:EC180201.						



Declaration of Conformity:

1. The Radiated Emission and Conducted Transient Disturbances test result (Pass/Fail) which exclude measurement uncertainty.
Note that measurement values may risk exceeding the limit of regulation standard. If measurement uncertainty is included in test results.
2. The Radiated Emission and Conducted Transient Disturbances measurement uncertainty please refer to the "Measurement Uncertainty" section of the report.

Comments and explanations:

1. The test configuration and test mode were recorded in this test report are declared by the manufacturer.
2. Assessed against standard edition updated and added British Standards, no differences in product, test configurations and methods, therefore re-use of the test results from Sporton project number: :EC180201.

Reviewed by: Mark Ma

Report Producer: Amber Chiu



1. General Description of Equipment under Test

1.1. Basic Description of Equipment under Test

Product : SATA Flash Drive
Model Name : SH250-25, SV250-25, SX250-25(X=A~Z)
Power Supply Type : From Host System
The maximum operating frequency : 350 MHz

1.2. Feature of Equipment under Test

For a more detailed features description, please refer to the manufacturer's specifications or the User's Manual.

1.3. Table for Multiple Listing

Model Name	Description
SH250-25, SV250-25, SX250-25(X=A~Z)	The difference of models is in capacity and color

Note: The information is provided by manufacturer.

1.4. Table for Existing Change

Report No.	Description
EC180201	-
EC180201-01	1. The standard was update. (EN IEC 61000-3-2:2019) 2. The British Standard was add. (BS EN 55032:2015+A11:2020, BS EN IEC 61000-3-2:2019, BS EN 61000-3-3:2013+A1:2019, BS EN 55035:2017+A11:2020)

Note: The information is provided by manufacturer.



2. Test Configuration of Equipment under Test

2.1. Details of EUT Test Modes

Model: SV250-25, SH250-25 was selected as representative model for the test and its data was recorded in this report. The equipment under test was performed the following test modes:

Test Items	Description of test modes
Conducted Emission	Mode 1. SV250-25 (960GB) , R/W Mode 2. SH250-25 (80GB), R/W Cause "mode 1" generated the worst test result; it was reported as final data.
Radiated Emissions <below 1GHz>	Mode 1. SV250-25 (960GB) , R/W Mode 2. SH250-25 (80GB), R/W Cause "mode 1" generated the worst test result; it was reported as final data.
Radiated Emissions <above 1GHz>	Mode 1. SV250-25 (960GB) , R/W

Test Items	Description of test modes
Harmonic and Flicker Emissions	Mode 1. SV250-25 (960GB) , R/W
EMS	Mode 1. SV250-25 (960GB) , R/W



2.2. Description of Test System

Conducted emission and radiated emission below 1GHz

No.	Peripheral	Manufacturer	Model Number	FCC ID	Remarks
For Local					
A	Personal Computer	ASUS	M32CD	DoC	-
B	LCD Monitor	ASUS	VS197DE	DoC	-
C	Keyboard	ASUS	AW211	DoC	-
D	Mouse	ASUS	MOBTUO	DoC	-
E	Printer	Fuji Xerox	Phaser 3121	DoC	-
F	Portable External HDD	PQI	H566	DoC	-

Radiated emission above 1GHz

No.	Peripheral	Manufacturer	Model Number	FCC ID	Remarks
For Local					
A	Personal Computer	ASUS	M900TA	DoC	-
B	LCD Monitor	DELL	U2410f	DoC	-
C	Keyboard	Microsoft	1366	DoC	-
D	Mouse	Microsoft	1113	DoC	-
E	Printer	EPSON	C61	N/A	-
F	Portable External HDD	PQI	H566	DoC	-

EMS

No.	Peripheral	Manufacturer	Model Number	Signal Cable	Cable Type	Length (m)	Remarks
For Local							
A	Personal Computer	ASUS	M900TA	-	-	-	-
B	Keyboard	Microsoft	1576	USB Cable	AL-F-Shielded	2.0	-
C	Mouse	Microsoft	1113	USB Cable	AL-F-Shielded	1.8	-
D	LCD Monitor	ViewSonic	VS15032	D-SUB	D-Shielded	1.8	-

2.3. Connection Diagram of Test System

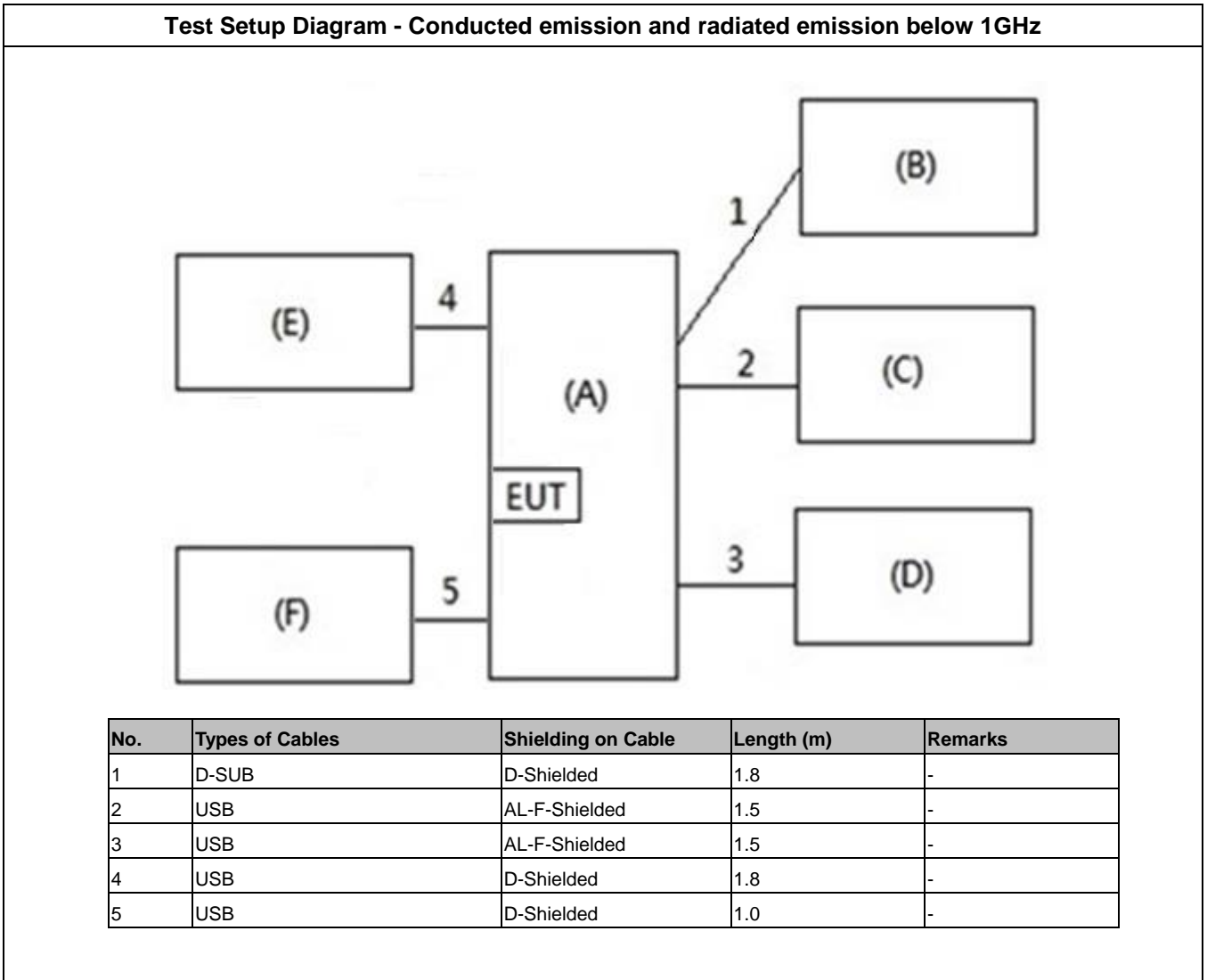

Test Setup Diagram - Radiated emission above 1GHz

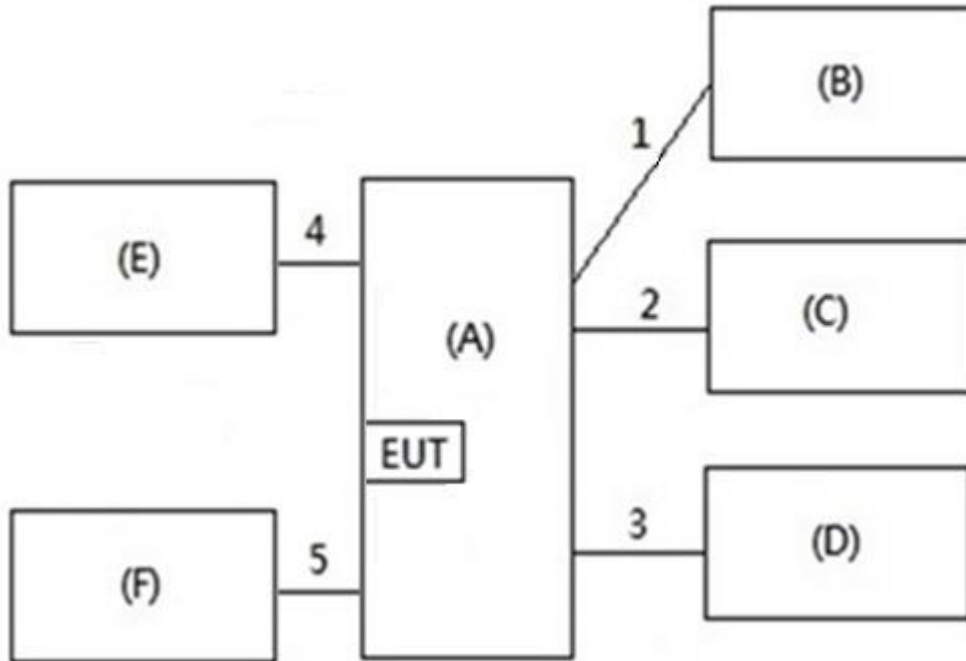

No.	Types of Cables	Shielding on Cable	Length (m)	Remarks
1	D-SUB	D-Shielded	1.5	-
2	USB	AL-F-Shielded	2.0	-
3	USB	AL-F-Shielded	1.8	-
4	USB	D-Shielded	1.8	-
5	USB	D-Shielded	1.0	-



2.4. Details of EUT Test Setup

EMI

An executive program, under WIN 10 (local) was used as the test software. The program was executed as follows:

- Turn on the power of all equipment.
- The Personal Computer executed "1729MPEG4" to keep displaying the color bar signal.
- The Personal Computer executed "Word" to keep the printer printing.
- The Personal Computer executed "BurnInTest" to keep the Portable External HDD & EUT reading/writing data.

EMS

During the test, the program under Win 10 was executed:

- The PC executed "Winthrax" to read and write data from EUT.

**3. General Information of Test****3.1. Test Facilities**

Test Lab : Sporton International Inc. Hsinhua Laboratory							
<input checked="" type="checkbox"/>	Hsinhua (TAF: 3785)	ADD : No.52, Huaya 1st Rd., Guishan Dist., Taoyuan City 333411, Taiwan (R.O.C.)					
		TEL : 886-3-327-3456			FAX : 886-3-327-0973		
<input checked="" type="checkbox"/>	Neihu (TAF: 3785)	ADD : No.3, Ln. 238, Kangle St., Neihu Dist., Taipei City 114040, Taiwan (R.O.C.)					
		TEL : 886-2-2631-5551			FAX : 886-2-2631-9740		
<input type="checkbox"/>	His Chih (TAF: 3785)	ADD : 6F, No.106, Sec. 1, Hsin Tai Wu Rd., His Chih, New Taipei City 221411, Taiwan (R.O.C.)					
		TEL : 886-2-2696-2468			FAX : 886-2-2696-2255		
Test Items	Test Site No.	Test Engineer	Test Environment			Test Date	Remark
			temp °C	humidity %	pressure kPa		
Powerline Conducted Emissions	CO01-NH	Willy Lee	25.8~25.9	51~52	-	10/Aug/2021	-
Radiated Emissions (below 1GHz)	OS03-NH	Louis Lin	26.3~26.4	55.1~55.3	-	09/Aug/2021	-
Radiated Emissions (above 1GHz)	03CH04-HY	Alan Chen	28.4~28.5	66~67	-	13/Aug/2021	-
Harmonic Current Emissions	EX02-HY	Jaily	24.6~24.7	41~42	100	21/Aug/2021	-
Voltage Fluctuations and Flicker	EX02-HY	Jaily	24.6~24.7	41~42	100	21/Aug/2021	-
ESD	ES01-HY	Jaily	22.3~22.9	44~45	100	21/Aug/2021	-
RS	RS06-HY	Jaily	23.3~23.6	51~52	100	21/Aug/2021	-
Power Frequency Magnetic Fields	EX02-HY	Jaily	24.6~24.7	41~42	100	21/Aug/2021	-



3.2. Test Standards

Test items	Test Standards and Test Procedures
Radiated and Conducted Emissions	European Standard EN 55032 Class B British Standard BS EN 55032 Class B
Harmonics	European Standard EN IEC 61000-3-2 British Standard BS EN IEC 61000-3-2
Voltage Fluctuations	European Standard EN 61000-3-3 British Standard BS EN 61000-3-3
EMS	European Standard EN 55035 British Standard BS EN 55035 (ESD: IEC 61000-4-2, RS: IEC 61000-4-3, EFT: IEC 61000-4-4, SURGES: IEC 61000-4-5, CS: IEC 61000-4-6, PFMF: IEC 61000-4-8, DIPs: IEC 61000-4-11)

3.3. Test Voltage/Frequencies

Power Supply Type	Voltage/Frequencies
Host System	230V / 50Hz

3.4. Test Distance and Frequency Range Investigated

Test Items	Frequency Range	Remark
Powerline Conducted Emissions	150 kHz to 30 MHz	-
Radiated Emissions (below 1GHz)	30 MHz to 1,000 MHz	Measurement distance is 10 m.
Radiated Emissions (above 1GHz)	1,000 MHz to 6,000 MHz	Measurement distance is 3 m.
Radio frequency electromagnetic field immunity	80 to 1,000 MHz	Measurement distance is 3 m.
	1,800 MHz / 2,600 MHz / 3,500 MHz / 5,000 MHz	Measurement distance is 3 m.

3.5. Operating Condition

- Customers request this specification for test plan.



4. Emissions Measurement

The EUT is which satisfies the Class B disturbance limits.

4.1. Conducted Emissions at Powerline

4.1.1. Limit

conducted emissions from the AC mains power ports of Class A equipment			
Frequency range MHz	Coupling device	Detector type / bandwidth	Class A limits dB(μ V)
0,15 – 0,5	AMN	Quasi-peak / 9 kHz	79
0,50 – 30			73
0,15 – 0,5	AMN	Average / 9 kHz	66
0,50 – 30			60

conducted emissions from the AC mains power ports of Class B equipment			
Frequency range MHz	Coupling device	Detector type / bandwidth	Class B limits dB(μ V)
0,15 – 0,5	AMN	Quasi-peak / 9 kHz	66 - 56
0,5 – 5			56
5 – 30			60
0,15 – 0,5	AMN	Average / 9 kHz	56 - 46
0,5 – 5			46
5 – 30			50

Note: The limit decreases linearly with the logarithm of the frequency in the range 0.15 MHz to 0.50 MHz.



4.1.2. Test Procedures

Tabletop equipment:

- a). The EUT was warmed up for 15 minutes before testing started.
- b). The EUT was placed on a desk 0.8 meter height from the metal ground plane and 0.4 meter from the conducting wall of the shielding room and it was kept at least 0.8 meter from any other grounded conducting surface.
- c). Connect EUT to the power mains through a line impedance stabilization network (LISN).
- d). All the support units are connect to the other LISN.
- e). The LISN provides 50 ohm, coupling impedance for the measuring instrument.
- f). The CISPR states that a 50 ohm, 50 microhenry LISN should be used.
- g). Both sides of AC line were checked for maximum conducted interference.
- h). The frequency range from 150 kHz to 30 MHz was searched.
- i). Set the test-receiver system to Peak Detect Function and Specified Bandwidth with Maximum Hold Mode.
- j). All emissions not reported here are more than 10 dB below the prescribed limit.

Floor-standing equipment:

- a). The EUT was warmed up for 15 minutes before testing started.
- b). The EUT was placed on the horizontal ground reference plane, 0.15 meter above ground.
- c). Connect EUT to the power mains through a line impedance stabilization network (LISN).
- d). All the support units are connect to the other LISN.
- e). The LISN provides 50 ohm, coupling impedance for the measuring instrument.
- f). The CISPR states that a 50 ohm, 50 microhenry LISN should be used.
- g). Both sides of AC line were checked for maximum conducted interference.
- h). The frequency range from 150 kHz to 30 MHz was searched.
- i). Set the test-receiver system to Peak Detect Function and Specified Bandwidth with Maximum Hold Mode.
- j). All emissions not reported here are more than 10 dB below the prescribed limit.

4.1.3. Measurement Results Calculation

The measured Level is calculated using:

$$\text{Corrected Reading (dB}\mu\text{V)} = \text{LISN Factor} + \text{Cable Loss} + \text{Read Level}$$

For example at 0.3 MHz if the LISN Factor is 10.48 dB, the cable loss is 0.10 dB, the measured voltage is 36.39 dB μ V, the signal strength would be calculated:

$$\text{Corrected Reading (dB}\mu\text{V)} = 10.48 \text{ dB} + 0.10 \text{ dB} + 36.39 \text{ dB}\mu\text{V} = 46.97 \text{ dB}\mu\text{V}$$

4.1.4. Typical Test Setup Layout

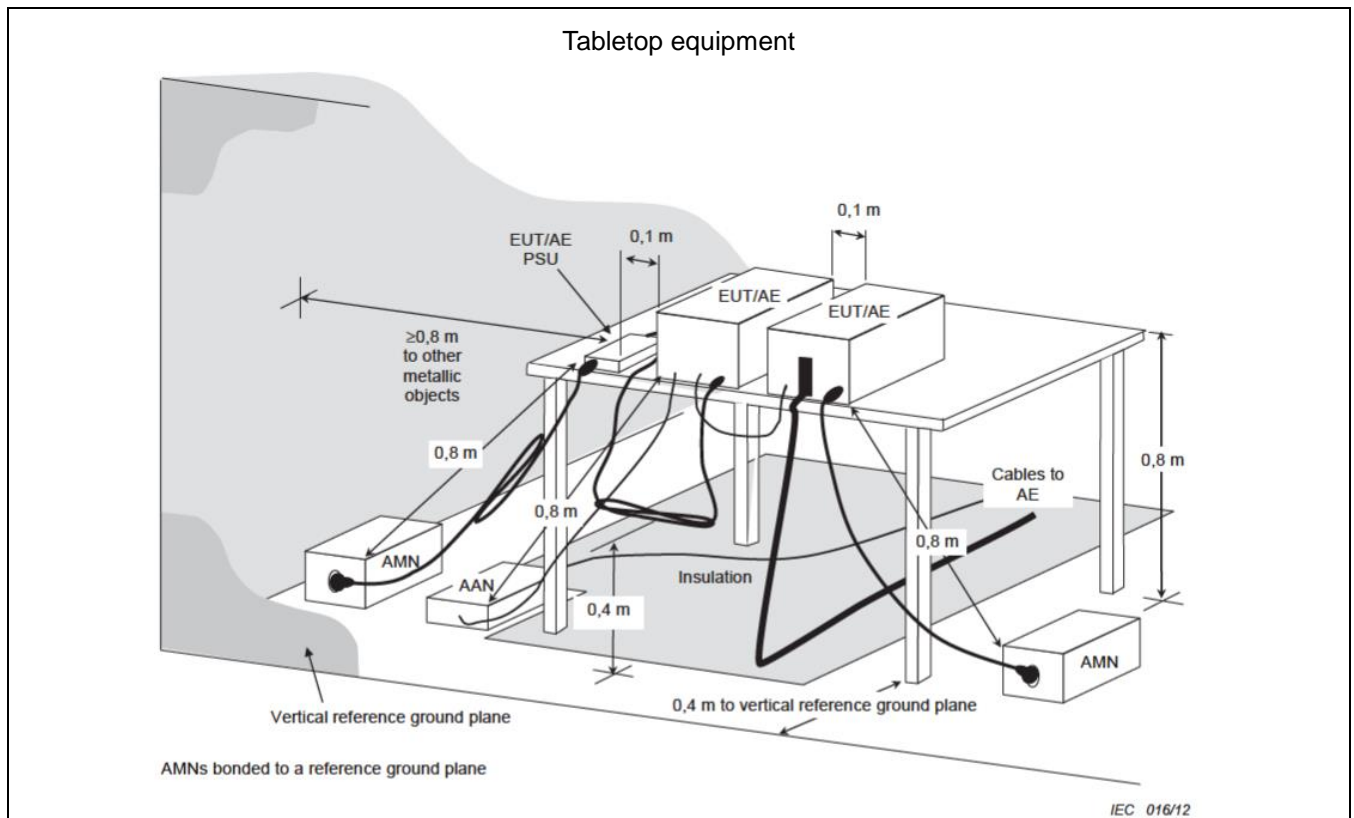

- a). AMN is 80 cm from the EUT and at least 80 cm from other units and other metal planes.
- b). EUT is connected to one artificial mains network (AMN)
- c). All other units of a system are powered from a second AMN. A multiple outlet strip can be used for multiple mains cords.
- d). Rear of EUT to be flushed with rear of table top.
- e). Peripherals shall be placed at a distance of 10 cm from each other and from the controller, except for the monitor which, if this is an acceptable installation practice, shall be placed directly on the top of the controller.
- f). If cables, which hang closer than 40 cm to the horizontal metal ground plane, cannot be shortened to appropriate length, the excess shall be folded back and forth forming a bundle 30 cm to 40 cm long.
- g). Mains cords and signal cables shall be positioned for their entire lengths, as far as possible, at 40 cm from the vertical reference plane.
- h). Cables of hand operated devices, such as keyboards, mice, etc. shall be placed as for normal usage.

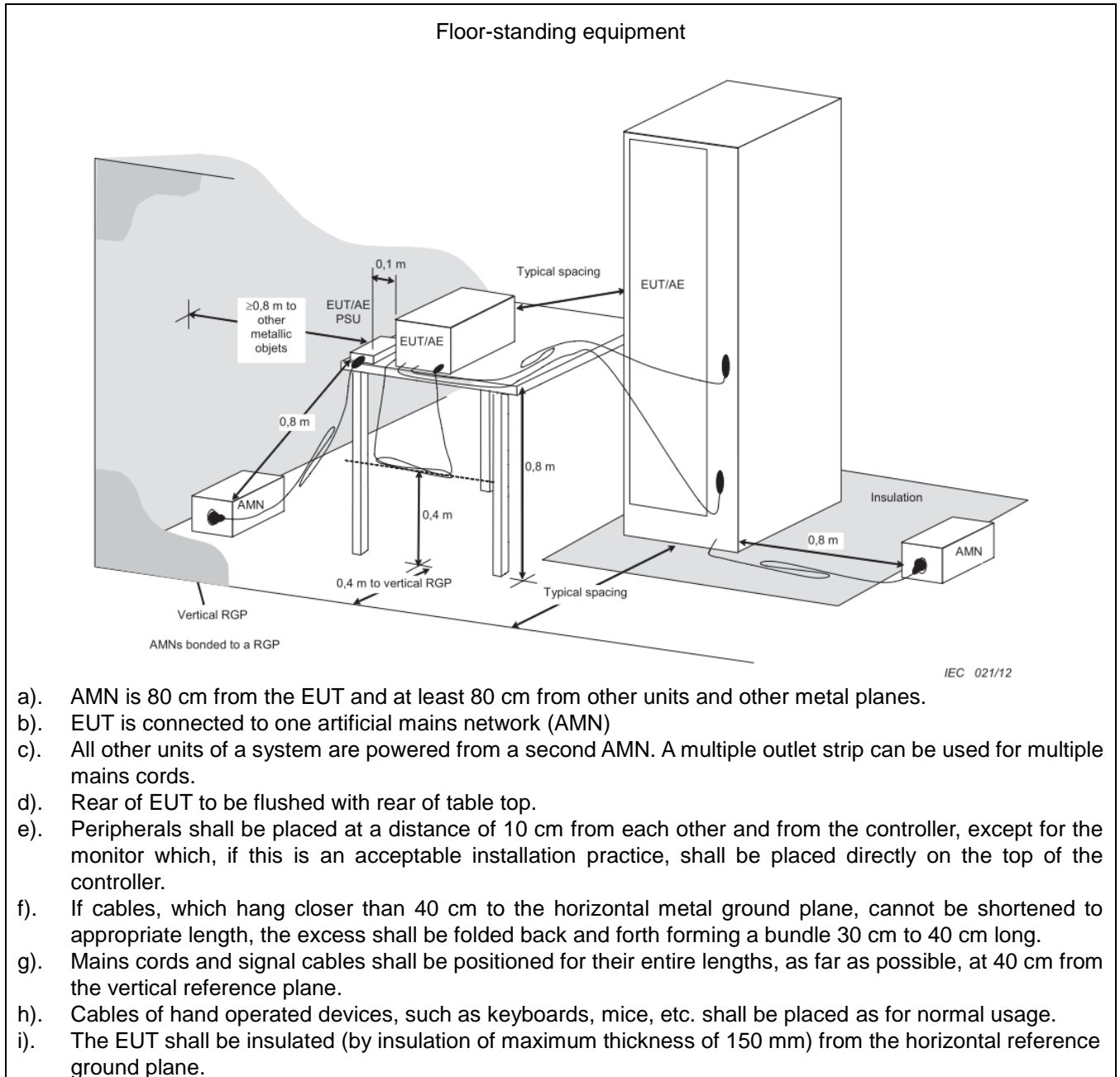



4.1.5. Test Result

Test Mode	Mode 1		
Test Frequency	0.15 MHz ~ 30 MHz	Test Voltage	AC 230V / 50Hz
<p>■ The test was passed at the minimum margin that marked by the frame in the following data</p>			

Line

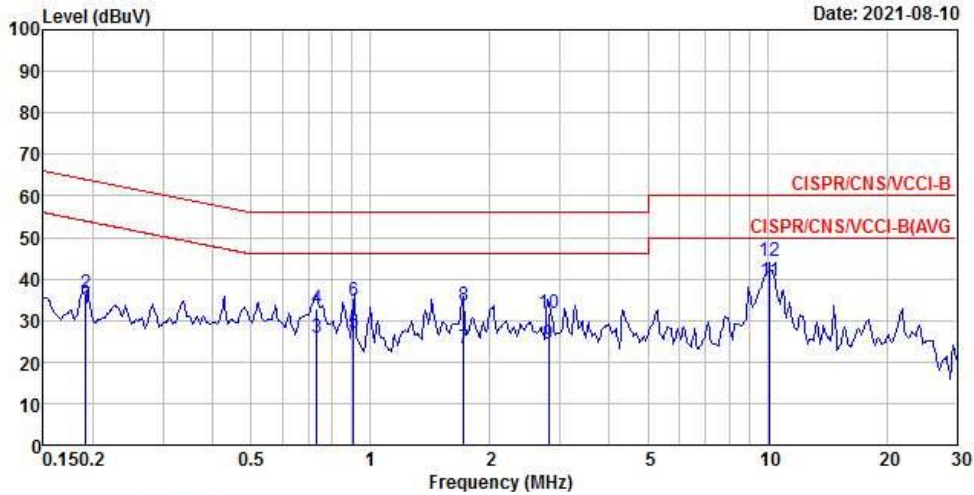

	Freq	Level	Over Limit	Limit Line	Read Level	LISN Factor	Cable Loss	Remark
	MHz	dBuV	dB	dBuV	dBuV	dB	dB	
1	0.19	32.85	-21.13	53.98	22.47	10.28	0.10	Average
2	0.19	36.40	-27.58	63.98	26.02	10.28	0.10	QP
3	0.73	26.01	-19.99	46.00	15.61	10.28	0.12	Average
4	0.73	32.83	-23.17	56.00	22.43	10.28	0.12	QP
5	0.91	26.95	-19.05	46.00	16.54	10.28	0.13	Average
6	0.91	34.85	-21.15	56.00	24.44	10.28	0.13	QP
7	1.72	23.34	-22.66	46.00	12.91	10.29	0.14	Average
8	1.72	33.50	-22.50	56.00	23.07	10.29	0.14	QP
9	2.82	24.50	-21.50	46.00	14.05	10.30	0.15	Average
10	2.82	31.68	-24.32	56.00	21.23	10.30	0.15	QP
11 @	10.13	39.48	-10.52	50.00	28.83	10.42	0.23	Average
12	10.13	44.27	-15.73	60.00	33.62	10.42	0.23	QP



Neutral

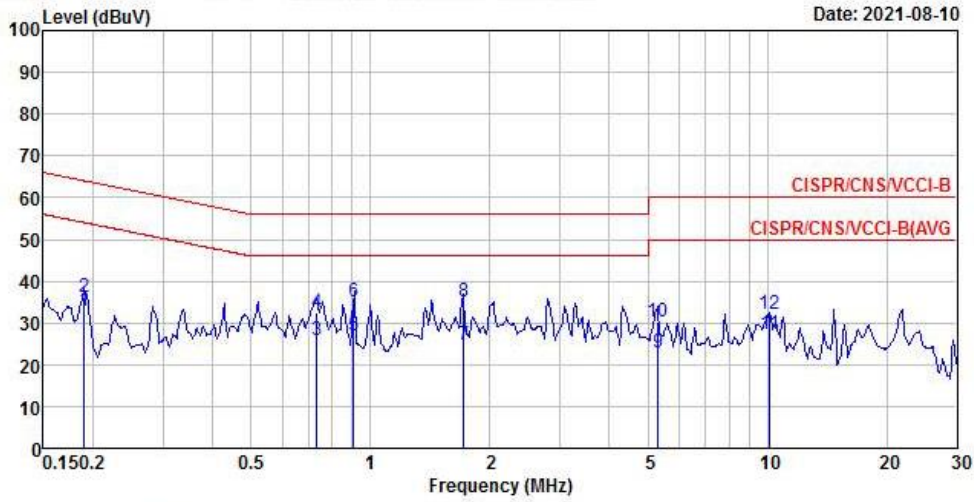

	Freq	Level	Over	Limit	Read	LISN	Cable	Remark
	MHz	dBuV	Limit	Line	Level	Factor	Loss	
			dB	dBuV	dBuV	dB	dB	
1	0.19	32.81	-21.21	54.02	22.42	10.29	0.10	Average
2	0.19	36.26	-27.76	64.02	25.87	10.29	0.10	QP
3	0.73	25.96	-20.04	46.00	15.56	10.28	0.12	Average
4	0.73	32.41	-23.59	56.00	22.01	10.28	0.12	QP
5 @	0.91	26.87	-19.13	46.00	16.46	10.28	0.13	Average
6	0.91	34.93	-21.07	56.00	24.52	10.28	0.13	QP
7	1.72	24.55	-21.45	46.00	14.11	10.30	0.14	Average
8	1.72	35.04	-20.96	56.00	24.60	10.30	0.14	QP
9	5.30	23.03	-26.97	50.00	12.48	10.37	0.18	Average
10	5.30	30.43	-29.57	60.00	19.88	10.37	0.18	QP
11	10.13	27.35	-22.65	50.00	16.67	10.45	0.23	Average
12	10.13	32.22	-27.78	60.00	21.54	10.45	0.23	QP



4.2. Radiated Emission below 1GHz

4.2.1.Limit

radiated emissions at frequencies up to 1 GHz for Class A equipment			
Frequency range MHz	Measurement		Class A limits dB(µV/m)
	Distance (m)	Detector type / bandwidth	OATS/SAC
30 – 230	10	Quasi Peak / 120 kHz	40
230 – 1000			47
30 – 230	3		50
230 – 1000			57

radiated emissions at frequencies up to 1 GHz for Class B equipment			
Frequency range MHz	Measurement		Class B limits dB(µV/m)
	Distance (m)	Detector type / bandwidth	OATS/SAC
30 – 230	10	Quasi Peak / 120 kHz	30
230 – 1000			37
30 – 230	3		40
230 – 1000			47

4.2.2. Test Procedures

Tabletop equipment

- a). The EUT was placed on a rotatable table top 0.8 meter above ground.
- b). The EUT was set 10 meters from the interference-receiving antenna which was mounted on the top of a variable height antenna tower.
- c). The table was rotated 360 degrees to determine the position of the highest radiation.
- d). The antenna is a half wave dipole and its height is varied between one meter and four meters above ground to find the maximum value of the field strength both horizontal polarization and vertical polarization of the antenna are set to make the measurement.
- e). For each suspected emission the EUT was arranged to its worst case and then tune the antenna tower (from 1 M to 4 M) and turn table (from 0 degree to 360 degrees) to find the maximum reading.
- f). Set the test-receiver system to Peak Detect Function and specified bandwidth with Maximum Hold Mode.
- g). If the emission level of the EUT in peak mode was 3 dB lower than the limit specified, then testing will be stopped and peak values of EUT will be reported, otherwise, the emissions which do not have 3 dB margin will be repeated one by one using the quasi-peak method and reported.
- h). The central point of the EUT shall be positioned at the center of the turntable. The measurement distance is the shortest horizontal distance between an imaginary circular periphery just encompassing this arrangement and the calibration point of the antenna.

Floor-standing equipment:

- a). The EUT was placed on the horizontal ground reference plane, 0.15 meter above ground.
- b). The EUT was set 10 meters from the interference-receiving antenna which was mounted on the top of a variable height antenna tower.
- c). The table was rotated 360 degrees to determine the position of the highest radiation.
- d). The antenna is a half wave dipole and its height is varied between one meter and four meters above ground to find the maximum value of the field strength both horizontal polarization and vertical polarization of the antenna are set to make the measurement.
- e). For each suspected emission the EUT was arranged to its worst case and then tune the antenna tower (from 1 M to 4 M) and turn table (from 0 degree to 360 degrees) to find the maximum reading.
- f). Set the test-receiver system to Peak Detect Function and specified bandwidth with Maximum Hold Mode.



- g). If the emission level of the EUT in peak mode was 3 dB lower than the limit specified, then testing will be stopped and peak values of EUT will be reported, otherwise, the emissions which do not have 3 dB margin will be repeated one by one using the quasi-peak method and reported.
- h). The central point of the EUT shall be positioned at the centre of the turntable. The measurement distance is the shortest horizontal distance between an imaginary circular periphery just encompassing this arrangement and the calibration point of the antenna.

4.2.3. Measurement Results Calculation

The measured Level is calculated using:
Corrected Reading (dB μ V/m) = Antenna Factor + Cable Loss + Read Level – Preamp Factor
For example at 125 MHz if the Antenna Factor is 17.24 dB/m, the cable loss is 1.20 dB, the measured voltage is 35.80 dB μ V and the Preamp Factor is 27.18 dB, the signal strength would be calculated:
Corrected Reading (dB μ V/m) = 17.24 dB/m + 1.20 dB + 35.80 dB μ V - 27.18 dB = 27.06 dB μ V/m
Note: If a hybrid antenna is used, the antenna factor shall be the sum of the Antenna Factor + Attenuator Factor.

4.2.4. Typical Test Setup Layout

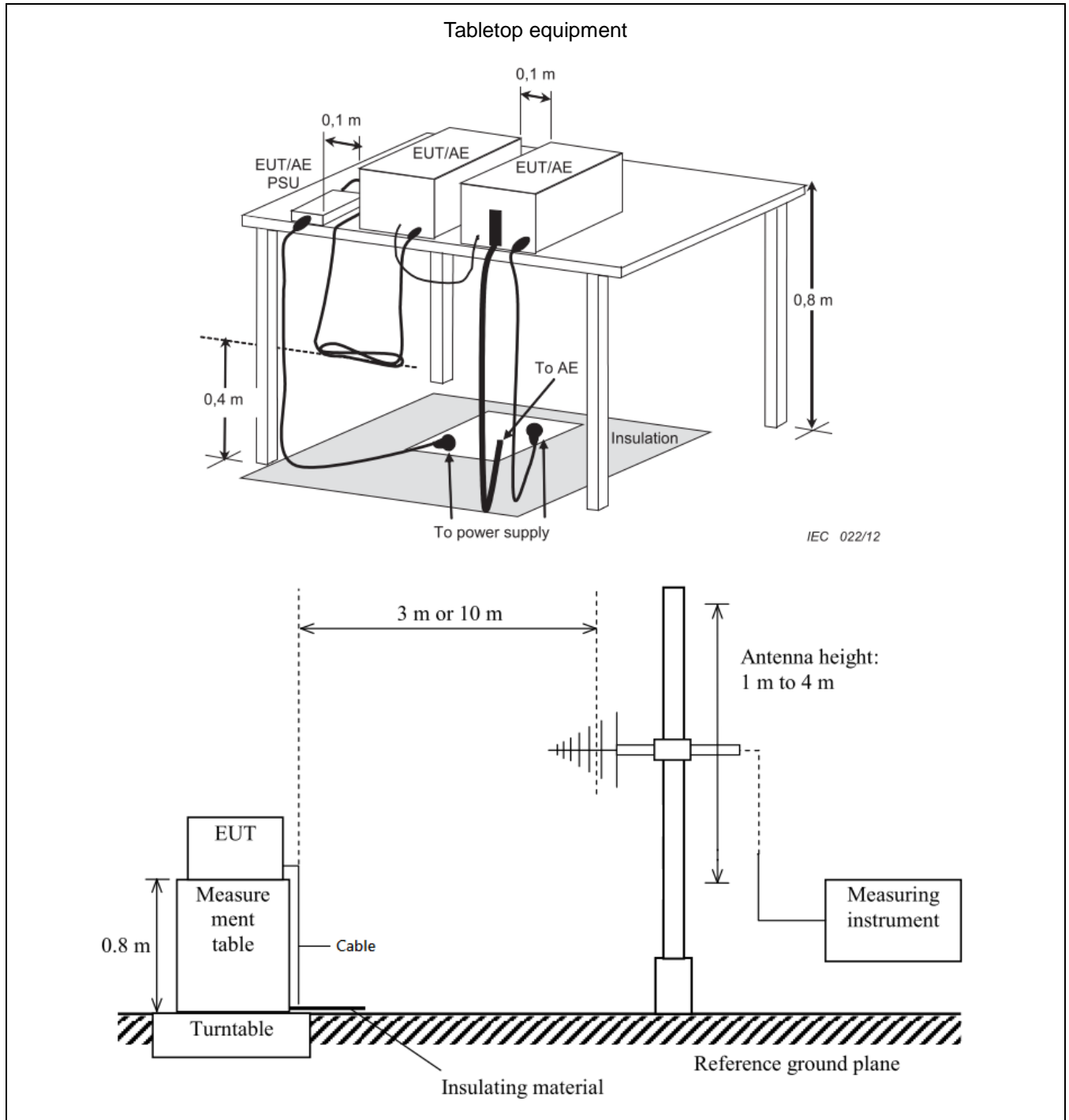

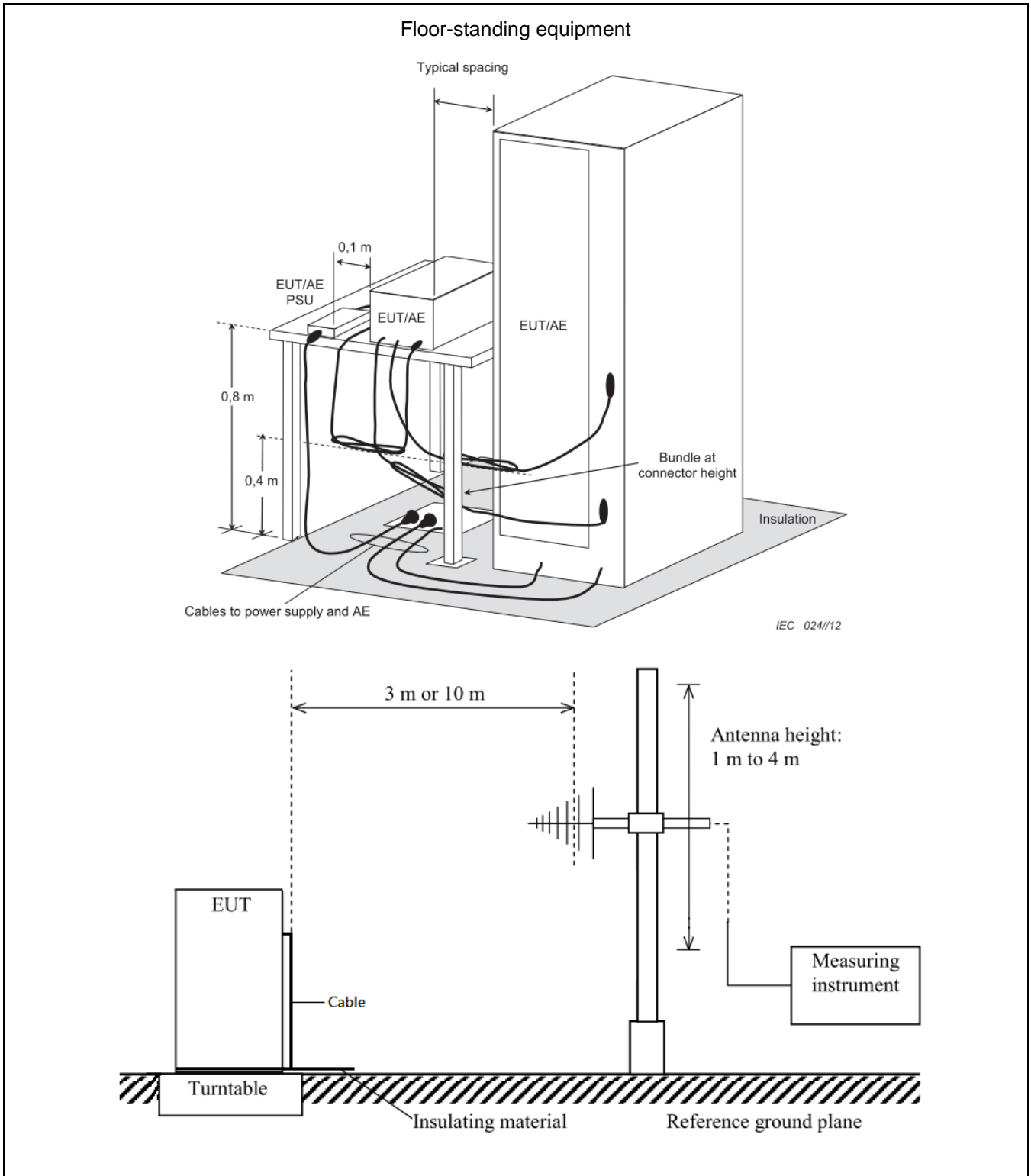



4.2.5. Test Result

Test mode	Mode 1		
Test frequency	30 MHz ~ 1000 MHz	Test Voltage	AC 230V / 50Hz
<p>■ The test was passed at the minimum margin that marked by the frame in the following data</p>			

Vertical

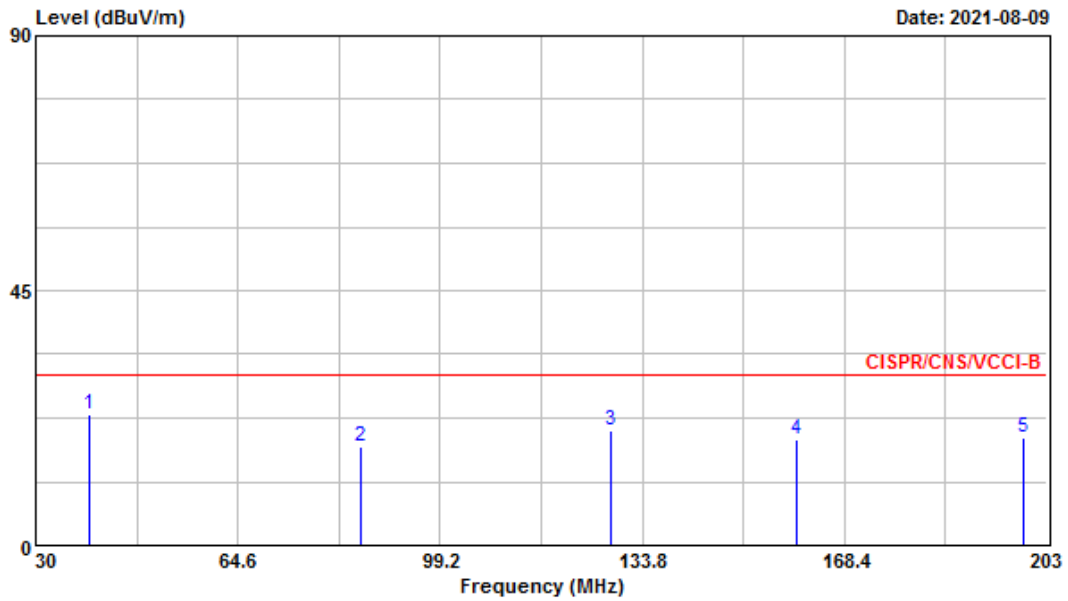

	Freq	Level	Over Limit	Limit Line	ReadAntenna Level	Antenna Factor	Cable Loss	Preamp Factor	Remark	Ant Pos	Table Pos
	MHz	dBuV/m	dB	dBuV/m	dBuV	dB/m	dB	dB		cm	deg
1	39.170	23.15	-6.85	30.00	32.43	18.11	1.08	28.47	Peak	100	181
2	85.710	17.44	-12.56	30.00	31.24	13.00	1.60	28.40	Peak	---	---
3	128.440	20.26	-9.74	30.00	28.86	17.60	2.08	28.28	Peak	---	---
4	160.270	18.68	-11.32	30.00	29.19	15.27	2.40	28.18	Peak	---	---
5	199.020	18.97	-11.03	30.00	29.79	14.48	2.69	27.99	Peak	---	---



Vertical

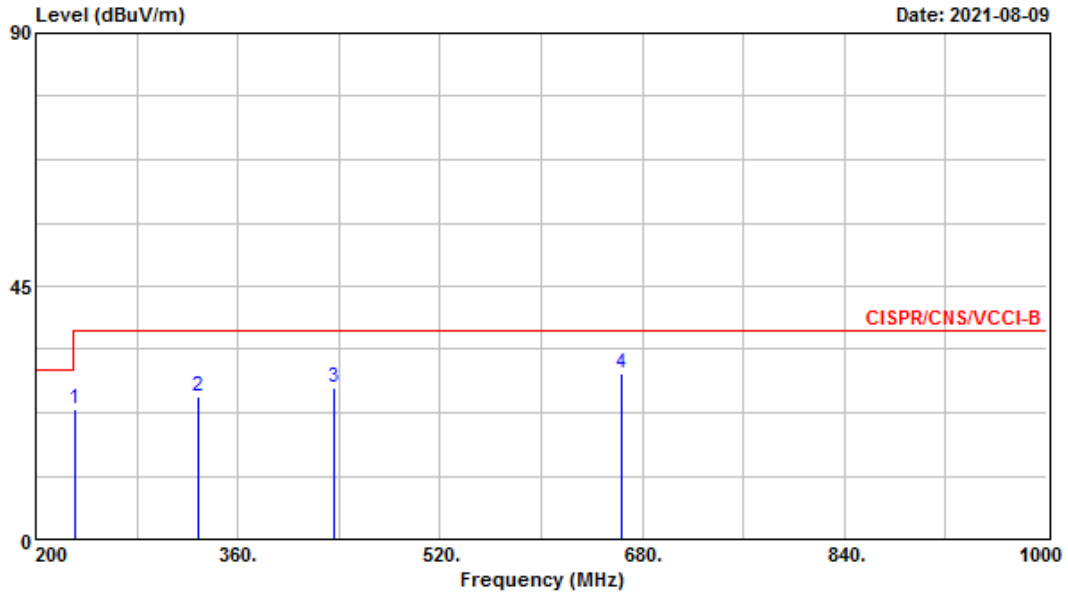

	Freq	Level	Over Limit	Limit Line	ReadAntenna Level	Antenna Factor	Cable Loss	Preamp Factor	Remark	Ant Pos	Table Pos
	MHz	dBuV/m	dB	dBuV/m	dBuV	dB/m	dB	dB		cm	deg
1	231.200	23.29	-13.71	37.00	32.73	15.41	3.01	27.86	Peak	---	---
2	328.800	25.40	-11.60	37.00	30.77	18.93	3.70	28.00	Peak	---	---
3	436.000	26.92	-10.08	37.00	29.83	21.73	4.15	28.79	Peak	---	---
4	664.000	29.52	-7.48	37.00	29.20	23.91	5.60	29.19	Peak	---	---



Horizontal

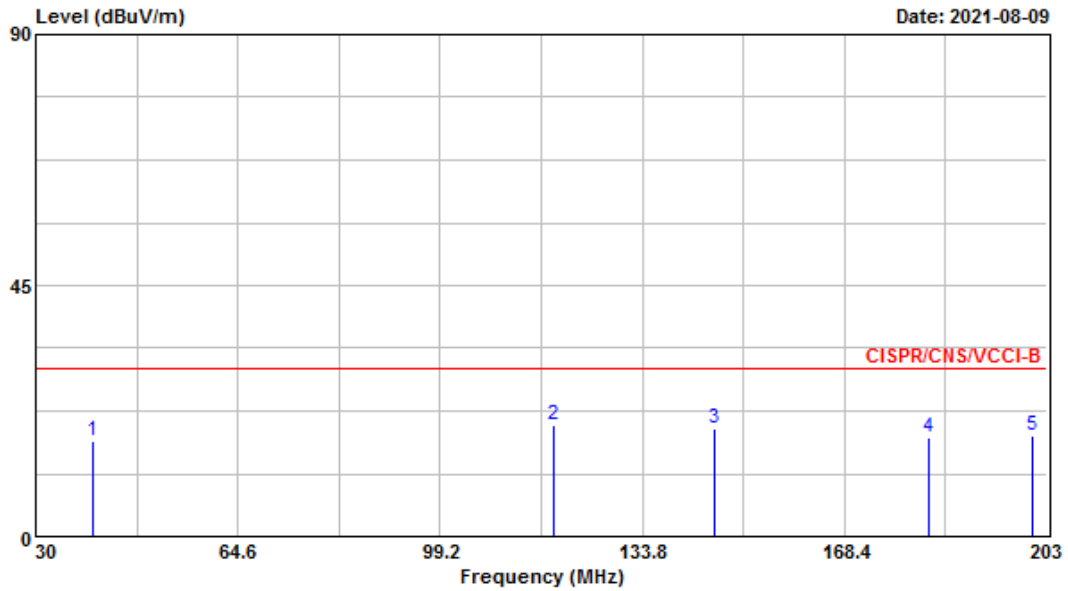

	Freq	Level	Over Limit	Limit Line	HeadAntenna Level	Antenna Factor	Cable Loss	Preamp Factor	Remark	Ant Pos	Table Pos
	MHz	dBuV/m	dB	dBuV/m	dBuV	dB/m	dB	dB		cm	deg
1	39.860	17.08	-12.92	30.00	26.73	17.72	1.10	28.47	Peak	---	---
2	118.580	20.07	-9.93	30.00	28.69	17.71	1.98	28.31	Peak	---	---
3	146.080	19.23	-10.77	30.00	29.18	16.00	2.27	28.22	Peak	---	---
4	182.760	17.65	-12.35	30.00	28.62	14.61	2.52	28.10	Peak	---	---
5	200.580	18.12	-11.88	30.00	29.03	14.36	2.71	27.98	Peak	---	---



Horizontal

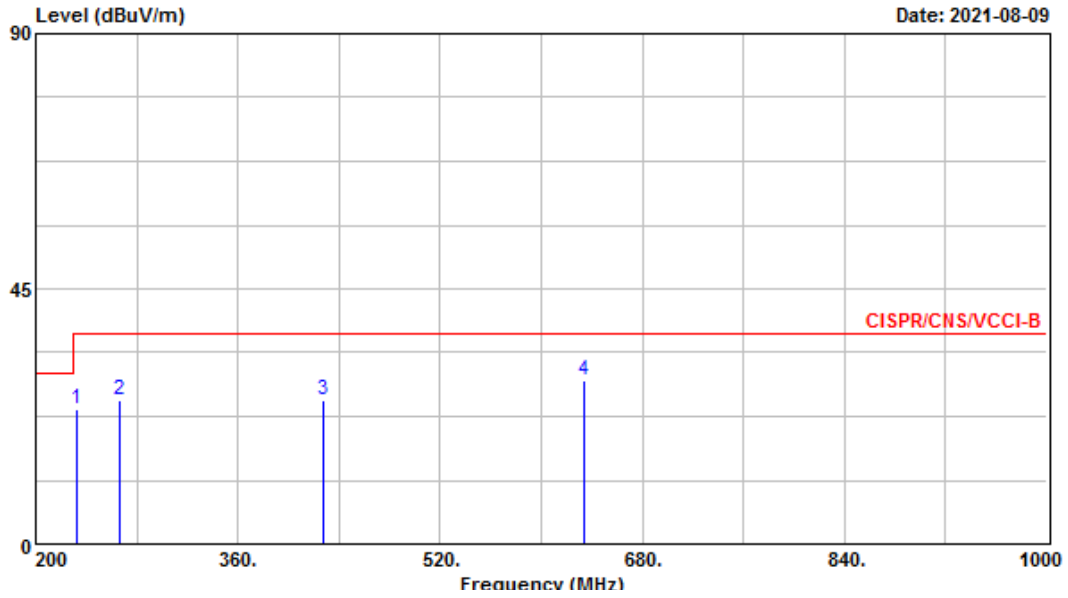

	Freq	Level	Over Limit	Limit Line	ReadAntenna Level	Antenna Factor	Cable Loss	Preamp Factor	Remark	Ant Pos	Table Pos
	MHz	dBuV/m	dB	dBuV/m	dBuV	dB/m	dB	dB		cm	deg
1	232.800	23.65	-13.35	37.00	32.83	15.65	3.03	27.86	Peak	---	---
2	266.400	25.23	-11.77	37.00	31.49	18.32	3.23	27.81	Peak	---	---
3	427.200	25.29	-11.71	37.00	28.24	21.66	4.11	28.72	Peak	---	---
4	633.600	28.86	-8.14	37.00	28.57	23.97	5.50	29.18	Peak	---	---



4.3. Radiated Emission above 1GHz

4.3.1. Limit

radiated emissions at frequencies above 1 GHz for Class A equipment			
Frequency range MHz	Measurement		Class A limits dB(µV/m)
	Distance (m)	Detector type / bandwidth	SAC
1000 – 3000	3	Average / 1 MHz	56
3000 – 6000			60
1000 – 3000		Peak / 1 MHz	76
3000 – 6000			80

radiated emissions at frequencies above 1 GHz for Class B equipment			
Frequency range MHz	Measurement		Class B limits dB(µV/m)
	Distance (m)	Detector type / bandwidth	SAC
1000 – 3000	3	Average / 1 MHz	50
3000 – 6000			54
1000 – 3000		Peak / 1 MHz	70
3000 – 6000			74

Required highest frequency for radiated measurement	
Highest internal frequency (F_x)	Highest measured frequency
$F_x \leq 108$ MHz	1 GHz
108 MHz < $F_x \leq 500$ MHz	2 GHz
500 MHz < $F_x \leq 1$ GHz	5 GHz
$F_x > 1$ GHz	$5 \times F_x$ up to a maximum of 6 GHz



4.3.2. Test Procedures

Tabletop equipment:

- a). Same test set up as below 1GHz radiated testing.
- b). The EUT was set 3 meter from the interference-receiving antenna which was mounted on the top of a variable height antenna tower.
- c). There should be absorber placed between the EUT and Antenna and its located size should let the test site meet CISPR16-1-4 requirement.
- d). The table was rotated 360 degrees to determine the position of the highest radiation.
- e). The measured using a test-receiver system with both a peak and CISPR average detector.
- f). Set the DRG Horn Antenna at 1M height, and then run the turn table to get the maximum noise reading from Horizontal and Vertical polarity separately the test-receiver system to Peak Detect Function and specified bandwidth with Maximum Hold Mode.
- g). When EUT locating on the turn-table, and its height is over 172cm (Antenna's 3dB beam width of 6GHz is 27°), the DRG Horn Antenna must be raised up and descended down, then turning around the turn-table to get the maximum noise reading of the Horizontal and Vertical polarity separately. Note the maximum raise up height is same as the top of EUT.
- h). If emission level of the EUT in peak mode was 23dB lower than average limit (that means the emission level in peak mode also complies with the limit in average mode), then testing will be stopped and peak values of EUT will be reported, otherwise, the emissions will be measured in average mode again and reported.
- i). The central point of the EUT shall be positioned at the center of the turntable. The measurement distance is the shortest horizontal distance between an imaginary circular periphery just encompassing this arrangement and the calibration point of the antenna.

Floor-standing equipment:

- a). Same test set up as below 1GHz radiated testing.
- b). The EUT was set 3 meter from the interference-receiving antenna which was mounted on the top of a variable height antenna tower.
- c). There should be absorber placed between the EUT and Antenna and its located size should let the test site meet CISPR16-1-4 requirement.
- d). The table was rotated 360 degrees to determine the position of the highest radiation.
- e). The measured using a test-receiver system with both a peak and CISPR average detector.
- f). Set the DRG Horn Antenna at 1M height, then run the turn table to get the maximum noise reading from Horizontal and Vertical polarity separately the test-receiver system to Peak Detect Function and specified bandwidth with Maximum Hold Mode.
- g). When EUT locating on the turn-table, and its height is over 172cm (Antenna's 3dB beam width of 6GHz is 27°), the DRG Horn Antenna must be raised up and descended down, then turning around the turn-table to get the maximum noise reading of the Horizontal and Vertical polarity separately. Note the maximum raise up height is same as the top of EUT.
- h). If emission level of the EUT in peak mode was 23dB lower than average limit (that means the emission level in peak mode also complies with the limit in average mode), then testing will be stopped and peak values of EUT will be reported, otherwise, the emissions will be measured in average mode again and reported.
- i). The central point of the EUT shall be positioned at the centre of the turntable. The measurement distance is the shortest horizontal distance between an imaginary circular periphery just encompassing this arrangement and the calibration point of the antenna.

4.3.3. Measurement Results Calculation

The measured Level is calculated using:

$$\text{Corrected Reading (dB}\mu\text{V/m)} = \text{Raw(Read Level)} + \text{AF(Antenna Factor)} + \text{CL(Cable Loss)} - \text{PA(Preamp Factor)}$$

For example at 1980 MHz if the Antenna Factor is 26.19 dB/m, the cable loss is 4.08 dB, the measured voltage is 51.30 dB μ V and the Preamp Factor is 33.34 dB, the signal strength would be calculated:

$$\text{Corrected Reading (dB}\mu\text{V/m)} = 51.30 \text{ dB}\mu\text{V} + 26.19 \text{ dB/m} + 4.08 \text{ dB} - 33.34 \text{ dB} = 48.23 \text{ dB}\mu\text{V/m}$$

4.3.4. Typical Test Setup Layout

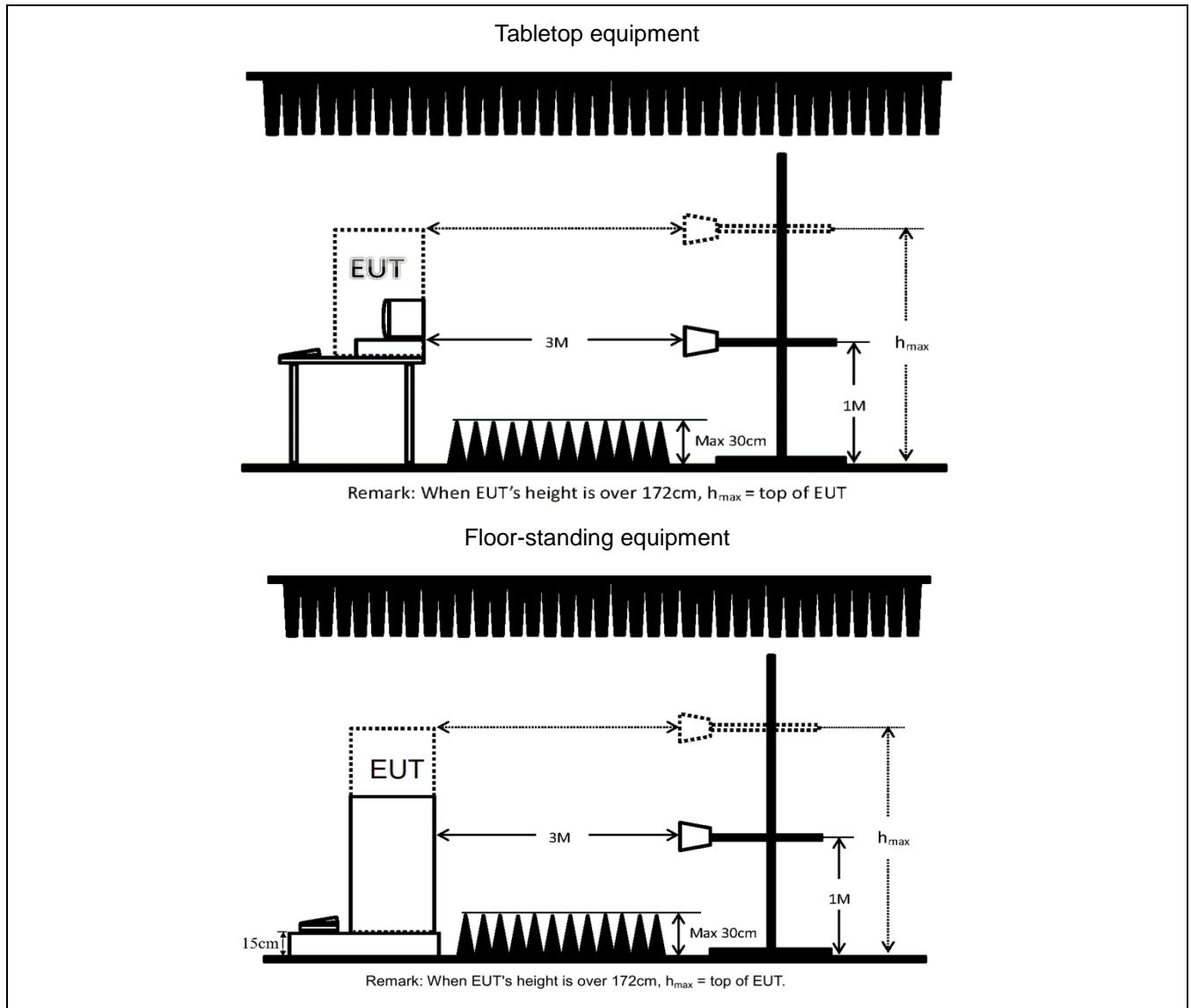



4.3.5. Test Result

Test mode	Mode 1		
Test frequency	1 GHz ~ 6 GHz	Test Voltage	AC 230V / 50Hz
<p>■ The test was passed at the minimum margin that marked by the frame in the following data</p>			

Vertical

Mode 1

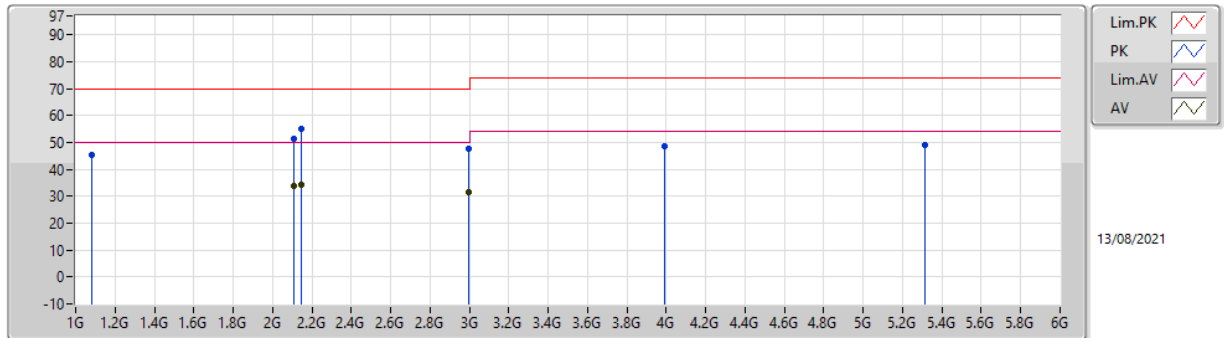

Type	Freq (Hz)	Level (dBuV/m)	Limit (dBuV/m)	Margin (dB)	Factor (dB/m)	Dist (m)	Condition	Azimuth (°)	Height (m)	Comment	Raw (dBuV)	AF (dB/m)	CL (dB)	PA (dB)
PK	1.085G	45.56	70.00	-24.44	-6.56	3	Vertical	-	-	-	52.12	24.57	3.27	34.40
PK	2.11G	51.53	70.00	-18.47	-1.77	3	Vertical	180	1	-	53.30	27.30	4.65	33.72
AV	2.11G	33.94	50.00	-16.06	-1.77	3	Vertical	180	1	-	35.71	27.30	4.65	33.72
PK	2.145G	54.98	70.00	-15.02	-1.40	3	Vertical	190	1	"Worst"	56.38	27.65	4.68	33.73
AV	2.145G	34.15	50.00	-15.85	-1.40	3	Vertical	190	1	-	35.55	27.65	4.68	33.73
PK	2.995G	47.79	70.00	-22.21	-0.18	3	Vertical	200	1	-	47.97	28.31	5.60	34.09
AV	2.995G	31.54	50.00	-18.46	-0.18	3	Vertical	200	1	-	31.72	28.31	5.60	34.09
PK	3.99G	48.73	74.00	-25.27	2.77	3	Vertical	-	-	-	45.96	29.52	7.06	33.81
PK	5.315G	49.06	74.00	-24.94	4.58	3	Vertical	-	-	-	44.48	31.13	7.53	34.08



Horizontal

Mode 1

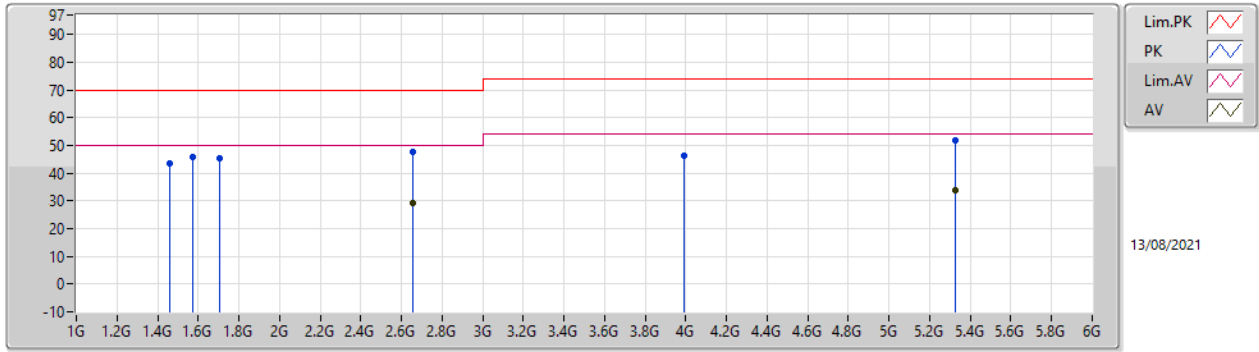

Type	Freq (Hz)	Level (dBuV/m)	Limit (dBuV/m)	Margin (dB)	Factor (dB/m)	Dist (m)	Condition	Azimuth (°)	Height (m)	Comment	Raw (dBuV)	AF (dB/m)	CL (dB)	PA (dB)
PK	1.46G	43.73	70.00	-26.27	-3.79	3	Horizontal	-	-	-	47.52	26.22	3.75	33.76
PK	1.57G	45.94	70.00	-24.06	-4.36	3	Horizontal	-	-	-	50.30	25.44	3.89	33.69
PK	1.705G	45.16	70.00	-24.84	-4.44	3	Horizontal	-	-	-	49.60	25.11	4.14	33.69
PK	2.655G	47.75	70.00	-22.25	-1.17	3	Horizontal	180	1	-	48.92	27.71	5.04	33.92
AV	2.655G	29.27	50.00	-20.73	-1.17	3	Horizontal	180	1	-	30.44	27.71	5.04	33.92
PK	3.99G	46.08	74.00	-27.92	2.77	3	Horizontal	-	-	-	43.31	29.52	7.06	33.81
PK	5.325G	51.90	74.00	-22.10	4.61	3	Horizontal	220	1	-	47.29	31.15	7.54	34.08
AV	5.325G	33.83	54.00	-20.17	4.61	3	Horizontal	220	1	"Worst"	29.22	31.15	7.54	34.08

4.4. Harmonic Current Emissions Measurement

4.4.1. Limit

Harmonic current emissions evaluate the potential for the EUT to cause distortion on the AC power lines. It is applicable to electrical and electronic equipment having an input current ≤ 16 A per phase, and intended to be connected to public low-voltage distribution systems.

Harmonics [n]	Class A [A]	Class B [A]	Class C [% of fund]	Class D [mA/W]
Odd harmonics				
3	2.30	3.45	30 x λ	3.4
5	1.14	1.71	10	1.9
7	0.77	1.155	7	1.0
9	0.40	0.60	5	0.5
11	0.33	0.495	3	0.35
13	0.21	0.315	3	3.85/13
15 $\leq n \leq 39$	0.15 x 15/n	0.225 x 15/n	3	3.85/n
Even harmonics				
2	1.08	1.62	2	-
4	0.43	0.645	-	-
6	0.30	0.45	-	-
8 $\leq n \leq 40$	0.23 x 8/n	0.345 x 8/n	-	-

4.4.2. Test Procedure

The test procedures followed are those specified in EN IEC 61000-3-2:2019, BS EN IEC 61000-3-2:2019.

4.4.3. Test Equipment Settings

Harmonic Parameters	Setting
Line Voltage	230 V
Line Frequency	50 Hz
Current Measurement Range	High
Measurement Delay	10.0 seconds
Test Duration	10.0 minutes
Class determination Pre-test Duration	10.0 seconds

4.4.4. Typical Test Setup Layout

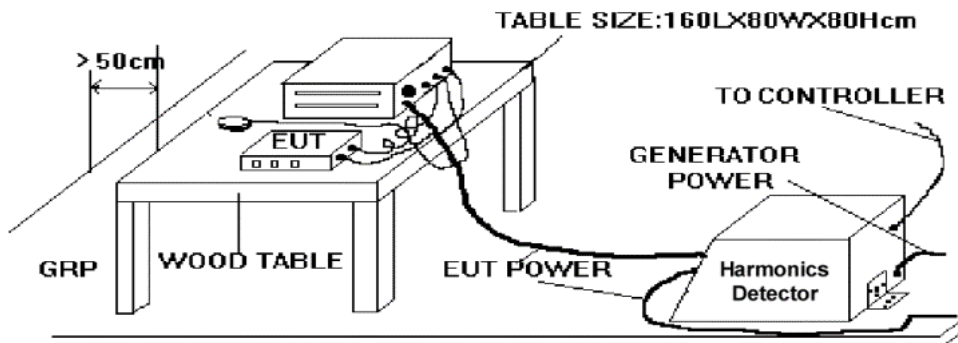



4.4.5. Test Result

Test mode	Mode 1		
Test Voltage	AC 230V / 50Hz	Device Class	A

V_RMS (Volts): 230.96
 I_Peak (Amps): 1.064
 I_Fund (Amps): 0.499
 Power (Watts): 107.0

Frequency(Hz): 50.00
 I_RMS (Amps): 0.584
 Crest Factor: 2.168
 Power Factor: 0.925

Harm#	Harms(avg)	100%Limit	%of Limit	Harms(max)	150%Limit	%of Limit	Status
2	0.001	1.080	N/A	0.002	1.620	N/A	Pass
3	0.070	2.300	3.0	0.072	3.450	2.1	Pass
4	0.000	0.430	N/A	0.001	0.645	N/A	Pass
5	0.034	1.140	3.0	0.035	1.710	2.1	Pass
6	0.000	0.300	N/A	0.001	0.450	N/A	Pass
7	0.019	0.770	2.5	0.020	1.155	1.7	Pass
8	0.000	0.230	N/A	0.001	0.345	N/A	Pass
9	0.013	0.400	3.2	0.013	0.600	2.2	Pass
10	0.000	0.184	N/A	0.001	0.276	N/A	Pass
11	0.010	0.330	3.0	0.010	0.495	2.1	Pass
12	0.000	0.153	N/A	0.001	0.230	N/A	Pass
13	0.008	0.210	3.6	0.008	0.315	2.6	Pass
14	0.000	0.131	N/A	0.001	0.197	N/A	Pass
15	0.006	0.150	4.1	0.007	0.225	2.9	Pass
16	0.000	0.115	N/A	0.001	0.173	N/A	Pass
17	0.005	0.132	4.2	0.006	0.198	3.2	Pass
18	0.000	0.102	N/A	0.001	0.153	N/A	Pass
19	0.005	0.118	4.2	0.005	0.178	3.0	Pass
20	0.001	0.092	N/A	0.001	0.138	N/A	Pass
21	0.005	0.107	4.7	0.005	0.161	3.3	Pass
22	0.000	0.084	N/A	0.001	0.125	N/A	Pass
23	0.005	0.098	N/A	0.005	0.147	N/A	Pass
24	0.001	0.077	N/A	0.001	0.115	N/A	Pass
25	0.004	0.090	N/A	0.005	0.135	N/A	Pass
26	0.001	0.071	N/A	0.001	0.107	N/A	Pass
27	0.005	0.083	N/A	0.005	0.125	N/A	Pass
28	0.001	0.066	N/A	0.001	0.099	N/A	Pass
29	0.004	0.078	N/A	0.005	0.116	N/A	Pass
30	0.001	0.061	N/A	0.001	0.092	N/A	Pass
31	0.004	0.073	N/A	0.005	0.109	N/A	Pass
32	0.001	0.058	N/A	0.004	0.086	N/A	Pass
33	0.004	0.068	N/A	0.004	0.102	N/A	Pass
34	0.001	0.054	N/A	0.004	0.081	N/A	Pass
35	0.004	0.064	N/A	0.004	0.096	N/A	Pass
36	0.001	0.051	N/A	0.001	0.077	N/A	Pass
37	0.003	0.061	N/A	0.004	0.091	N/A	Pass
38	0.001	0.048	N/A	0.001	0.073	N/A	Pass
39	0.004	0.058	N/A	0.004	0.087	N/A	Pass
40	0.001	0.046	N/A	0.001	0.069	N/A	Pass

4.5. Voltage Fluctuations and Flicker Measurement

4.5.1. Limit

The objective of voltage changes, voltage fluctuations and flicker in public low voltage supply systems during equipment with rated current ≤ 16 A per phase, ensures that home appliances and certain other electrical equipment do not adversely affect lighting equipment when connected to the same power system.

Voltage Fluctuation and Flicker Limits:

- The value of P_{st} shall not be greater than 1.0.
- The value of P_t shall not be greater than 0.65.
- The value of $d(t)$ during a voltage change shall not exceed 3.3 % for more than 500 ms.
- The relative steady-state voltage change, d_c , shall not exceed 3.3 %.
- The maximum relative voltage change, d_{max} , shall not exceed 4.0 %.

4.5.2. Test Procedure

The test procedures followed are those specified in EN 61000-3-3:2013+A1:2019, BS EN 61000-3-3:2013+A1:2019 .

4.5.3. Test Equipment Settings

Flicker Parameters	Setting
Line Voltage	230 V
Line Frequency	50 Hz
Measurement Delay	10.0 seconds
Pst Integration Time	10.0 minutes
Pst Integration Periods	1
Test Duration	10.0 minutes

4.5.4. Typical Test Setup Layout

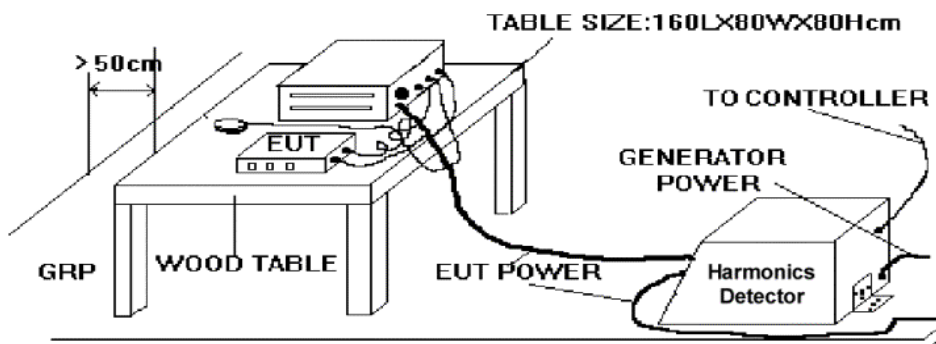



4.5.5. Test Result

Test mode	Mode 1	Test Voltage	AC 230V / 50Hz
------------------	--------	---------------------	----------------

Parameter values recorded during the test:

Vrms at the end of test (Volt):	230.87			
T-max (mS):	0	Test limit (mS):	500.0	Pass
Highest dc (%):	0.00	Test limit (%):	3.30	Pass
Highest dmax (%):	0.00	Test limit (%):	4.00	Pass
Highest Pst (10 min. period):	0.064	Test limit:	1.000	Pass



5. Immunity Measurement

5.1. General performance criteria

Applicable Standard: EN 55035, BS EN 55035,	
Criteria A	The equipment shall continue to operate as intended without operator intervention. No degradation of performance, loss of function or change of operating state is allowed below a performance level specified by the manufacturer when the equipment is used as intended. The performance level may be replaced by a permissible loss of performance. If the minimum performance level or the permissible performance loss is not specified by the manufacturer, then either of these may be derived from the product description and documentation, and by what the user may reasonably expect from the equipment if used as intended.
Criteria B	During the application of the disturbance, degradation of performance is allowed. However, no unintended change of actual operating state or stored data is allowed to persist after the test. After the test, the equipment shall continue to operate as intended without operator intervention; no degradation of performance or loss of function is allowed, below a performance level specified by the manufacturer, when the equipment is used as intended. The performance level may be replaced by a permissible loss of performance. If the minimum performance level (or the permissible performance loss), or recovery time, is not specified by the manufacturer, then either of these may be derived from the product description and documentation, and by what the user may reasonably expect from the equipment if used as intended.
Criteria C	Loss of function is allowed, provided the function is self-recoverable, or can be restored by the operation of the controls by the user in accordance with the manufacturer's instructions. A reboot or re-start operation is allowed. Information stored in non-volatile memory, or protected by a battery backup, shall not be lost.



5.2. Electrostatic Discharge (ESD)

5.2.1. Test Specification

Reference Standard	IEC 61000-4-2
Discharge Impedance	330 Ω / 150 pF
Polarity	Positive and negative
Single Discharge Mode	1 discharge per 1s

5.2.2. Test Levels

Contact Discharge		Air Discharge	
Level	Test Voltage kV	Level	Test Voltage kV
1	2	1	2
2	4	2	4
3	6	3	8
4	8	4	15
x	Specified	x	Specified

Remark : "x" can be any level, above, below or in between the others. The level shall be specified in the dedicated equipment specification. If higher voltages than those shown are specified, special test equipment may be needed.

5.2.3. Test Procedure

- a. In the case of air discharge testing the climatic conditions shall be within the following ranges:
 - ambient temperature: 15 °C to 35 °C;
 - relative humidity : 30 % to 60 %;
 - atmospheric pressure : 86 kPa (860 mbar) to 106 kPa (1060 mbar).
- b. Test programs and software shall be chosen so as to exercise all normal modes of operation of the EUT. The use of special exercising software is encouraged, but permitted only where it can be shown that the EUT is being comprehensively exercised.
- c. The test voltage shall be increased from the minimum to the selected test severity level, in order to determine any threshold of failure. The final severity level should not exceed the product specification value in order to avoid damage to the equipment.
- d. For the time interval between successive single discharges an initial value of one second is recommended. Longer intervals may be necessary to determine whether a system failure has occurred.
- e. In the case of contact discharges, the tip of the discharge electrode shall touch the EUT before the discharge switch is operated.
- f. In the case of painted surface covering a conducting substrate, the following procedure shall be adopted:
 - If the coating is not declared to be an insulating coating by the equipment manufacturer, then the pointed tip of the generator shall penetrate the coating so as to make contact with the conducting substrate.
 - Coating declared as insulating by the manufacturer shall only be submitted to the air discharge.
 - The contact discharge test shall not be applied to such surfaces.
- g. In the case of air discharges, the round discharge tip of the discharge electrode shall be approached as fast as possible (without causing mechanical damage) to touch the EUT. After each discharge, the ESD generator (discharge electrode) shall be removed from the EUT. The generator is then retriggered for a new single discharge. This procedure shall be repeated until the discharges are completed. In the case of an air discharge test, the discharge switch, which is used for contact discharge, shall be closed.

5.2.4. Test Setup

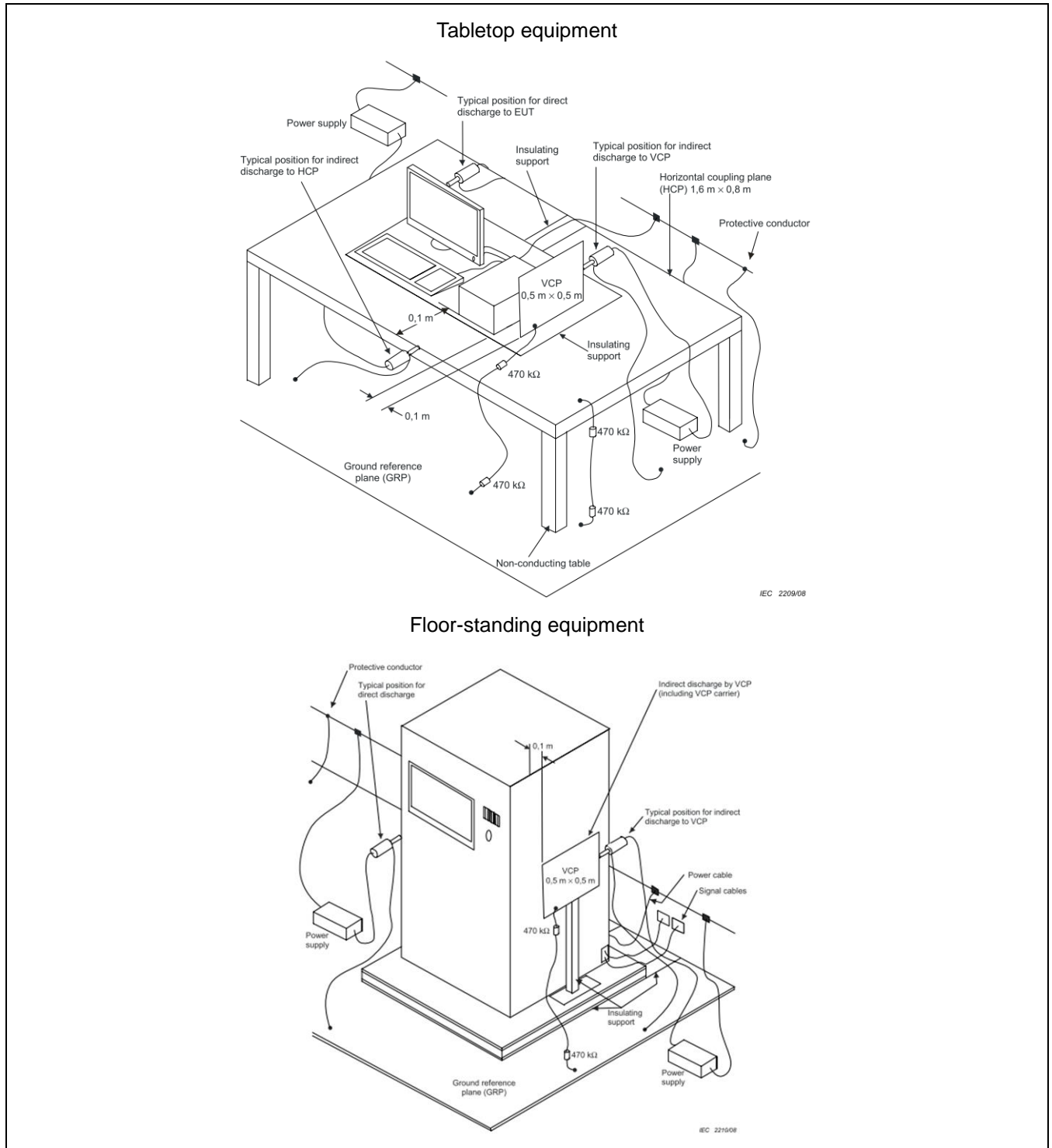



The test setup consists of the test generator, EUT and auxiliary instrumentation necessary to perform DIRECT and INDIRECT application of discharges to the EUT as applicable, in the follow manner:

- a). CONTACT DISCHARGE to the conductive surfaces and to coupling plane;
- b). AIR DISCHARGE at insulating surfaces.

The preferred test method is that of type tests performed in laboratories and the only accepted method of demonstrating conformance with this standard. The EUT was arranged as closely as possible to arrangement in final installed conditions.

5.2.5. Test Setup for Tests Performed in Laboratory

A ground reference plane was provided on the floor of the test site. It was a metallic sheet (copper or aluminum) of 0.25 mm, minimum thickness; other metallic may be used but they shall have at least 0.65 mm thickness. In the Hsinhua LAB., we provided 1 mm thickness aluminum ground reference plane or 1 mm thickness stainless steel ground reference plane. The minimum size of the ground reference plane is 1 m x 1 m, the exact size depending on the dimensions of the EUT. It was connected to the protective grounding system.

The EUT was arranged and connected according to its functional requirements. A distance of 1 m minimum was provided between the EUT and the wall of the Lab., and any other metallic structure. In cases where this length exceeds the length necessary to apply the discharges to the selected points, the excess length shall, where possible, be placed non-inductively off the ground reference plane and shall not come closer than 0.2 m to other conductive parts in the test setup.

Tabletop equipment:

Where the EUT is installed on a metal table, the table was connected to the reference plane via a cable with a 470k ohm resistor located at each end, to prevent a build-up of charge. The test setup was consist a wooden table, 0.8 m high, standing on the ground reference plane. A HCP, 1.6 m x 0.8 m, was placed on the table. The EUT and cables was isolated from the HCP by an insulating support 0.5 mm thick. The VCP size, 0.5 m x 0.5 m.

Floor-standing equipment:

The EUT shall be isolated from the ground reference plane by an insulating support of 0,05 m to 0,15 m thick. The EUT cables shall be isolated from the ground reference plane by an insulating support of $(0,5 \pm 0,05)$ mm. This cable isolation shall extend beyond the edge of the EUT isolation.

The VCP size, 0.5 m x 0.5 m

**5.2.6. Test Result**

Test mode	Mode 1		
Applicable Standard	EN 55035:2017+A11:2020 BS EN 55035:2017+A11:2020	Final Test Result	PASS
Contact discharge	2, 4 kV		
Air discharge	2, 4, 8 kV		
Performance Criteria	B		
Remark	ESD test directly on the PC.		

Test Result - Air Discharge/Round Tip

Test Point	No. of Disch.	Test Result (Criteria)						Remark
		+2kV	-2kV	+4kV	-4kV	+8kV	-8kV	
2	10	A	A	A	A	A	A	-

Test Result - Contact Discharge/Pointed Tip**Direct discharge**

Test Point	No. of Disch.	Test Result (Criteria)				Remark
		+2kV	-2kV	+4kV	-4kV	
1	10	A	A	A	A	-

Indirect discharge to HCP and VCP

Test Point	No. of Disch.	Test Result (Criteria)				Remark
		+2kV	-2kV	+4kV	-4kV	
HCP (At Front)	10	A	A	A	A	-
HCP (At Left)	10	A	A	A	A	-
HCP (At Right)	10	A	A	A	A	-
HCP (At Rear)	10	A	A	A	A	-
VCP (At Front)	10	A	A	A	A	-
VCP (At Left)	10	A	A	A	A	-
VCP (At Right)	10	A	A	A	A	-
VCP (At Rear)	10	A	A	A	A	-

5.2.7. Photographs of Electrostatic Discharge Immunity Test

Test Points

ESD TEST POINT

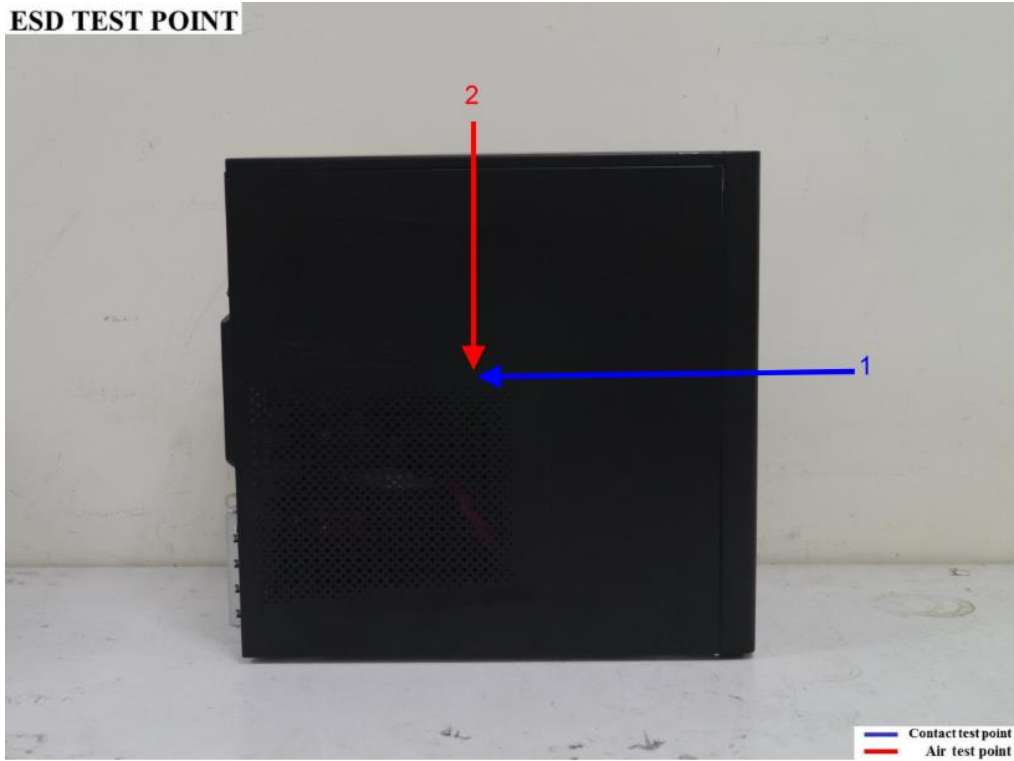

ESD TEST POINT

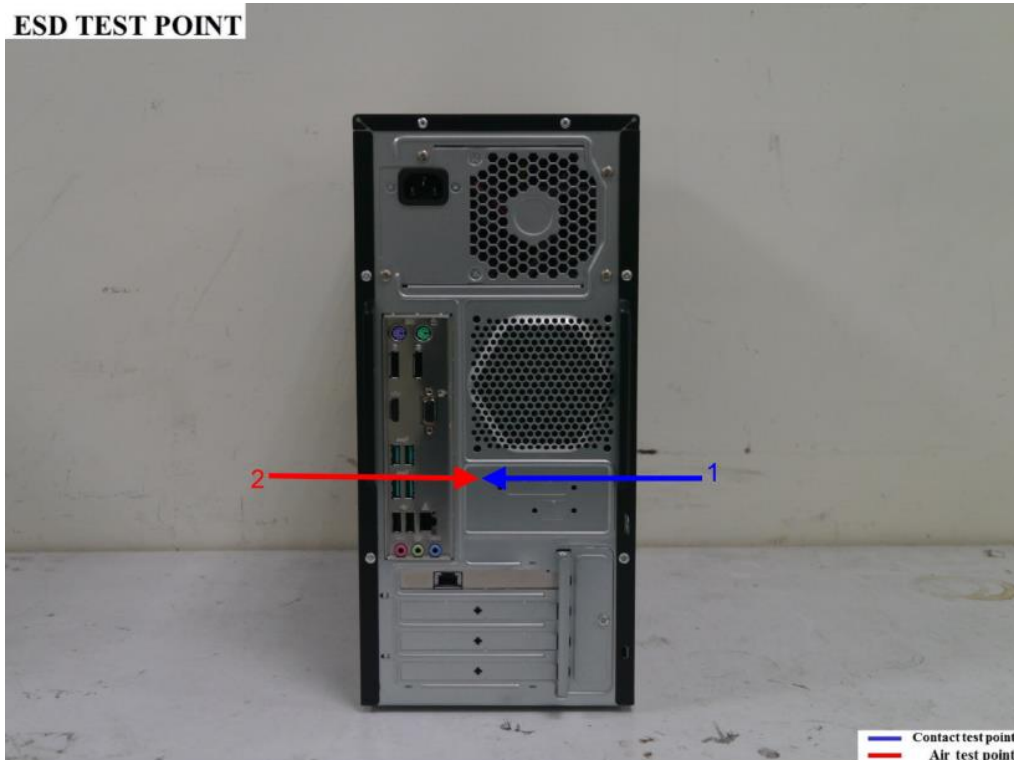

Test Points

ESD TEST POINT

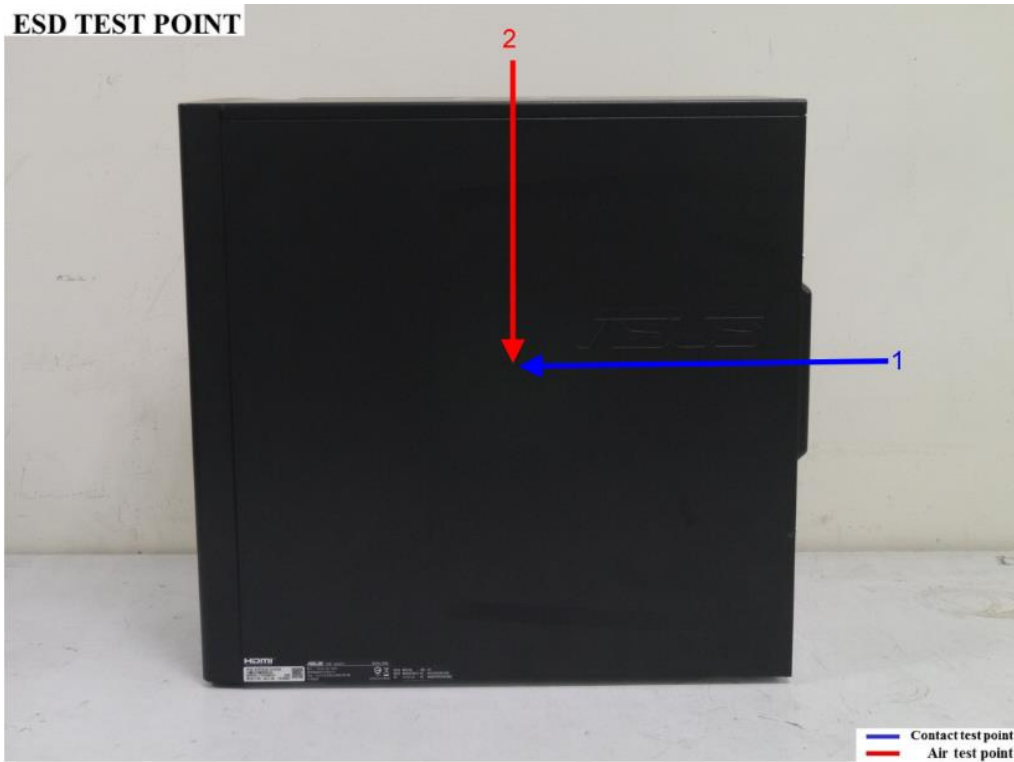

ESD TEST POINT

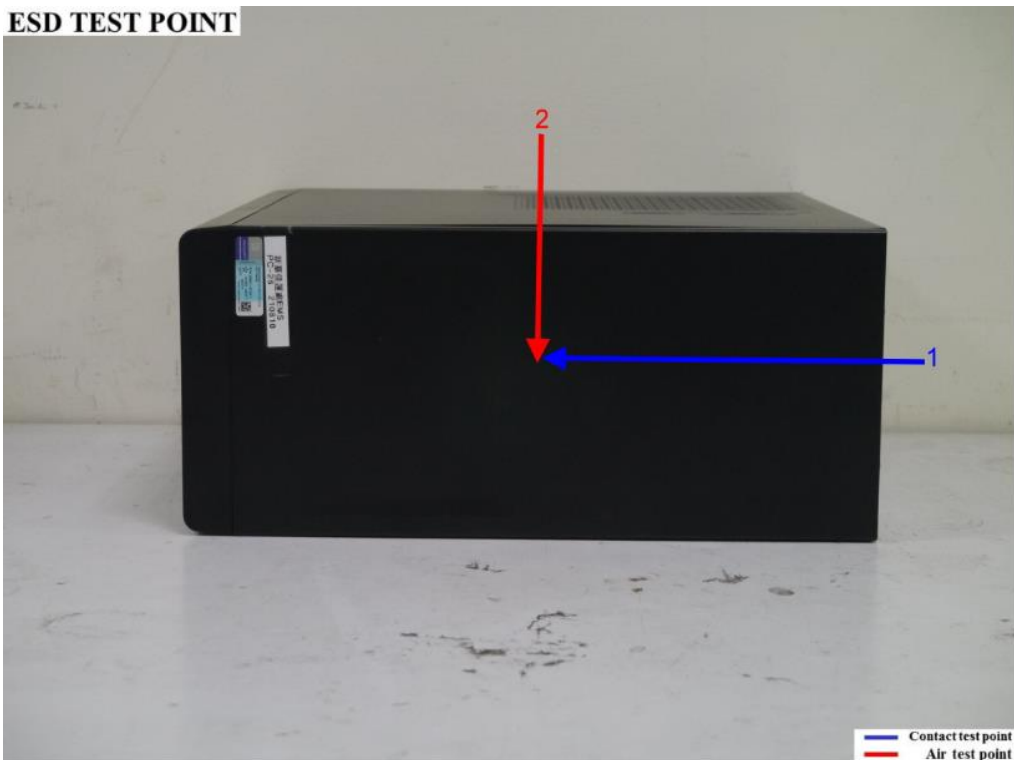



5.3. Radio Frequency Electromagnetic Field (RS)

5.3.1. Test Specification

Reference Standard	IEC 61000-4-3
Dwell Time	2.9 seconds
Frequency Step size	1 % of the preceding frequency value
Antenna Polarity	Vertical and Horizontal

5.3.2. Test Levels

Level	Test field strength V/m
1	1
2	3
3	10
4	30
x	Specified

Remark : "x" is an open test level and the associated field strength may be any value. This level may be given in the product standard.

If the audio output function needs to be test, the function should be maintained and the following requirements should be met

Performance criterion A – Limits for devices supporting telephony					
Type of immunity test	Frequency range MHz	Acoustic or electrical interference ratio	Equivalent direct measurement		
			dB(SPL)	Digital dBm0	Analogue dBm
Radiated	80 to 1,000	0dB	75	-30	-30
<p>The equivalent direct measurement values are presented to show the equivalency of the interference ratio in comparison to a direct measured value. These values may be used if the direct measurement method of the test is used.</p> <p>The values within this table are aligned with CISPR 24, noting that the test levels are different between this document and CISPR 24.</p> <p>For terminals connected to digital wired network ports (such as Ethernet, ISDN), measurements of the demodulated 1 kHz may be performed on a remote AE, ideally of the same design.</p>					
MME not supporting telephony reference level					
<p>A level within the expected dynamic range of the audio output, as intended by the manufacturer and is: at least 10 dB below the highest peak reproduced audio level occurring in normal use; and, below the highest level of reproduced audio that can be continuously output in normal use.</p> <p>The measured acoustic interference ratio and/or the measured electrical interference ratio during the test shall be -20 dB or better.</p>					

5.3.3. Test Procedure

- a). The equipment to be tested is placed in the center of the enclosure on a wooden table. The equipment is then connected to power and signal leads according to pertinent installation instructions.
- b). The bilog antenna which is enabling the complete frequency range of 80 to 1000 MHz, The horn antenna which is enabling the complete frequency range 1000 to 5000 MHz is placed 3m away from the equipment. The required field strength is determined by placing the field strength meter(s) on top of or directly alongside the equipment under test and monitoring the field strength meter via a remote field strength indicator outside the enclosure while adjusting the continuous-wave to the applicable antennae.
- c). The test is normally performed with the generating antenna facing each of four sides of the EUT. The polarization of the field generated by the broadband (bilog) antenna necessitates testing each position twice, once with the antenna positioned vertically and again with the antenna positioned horizontally.
- d). The dwell time at each frequency shall not be less than the time necessary for the EUT to be exercised, and able to respond. Sensitive frequencies e.g. clock frequency(ies) and harmonics or frequencies of dominant interest shall be analyzed separately.
- e). At each of the above conditions, the frequency range is swept 80 to 5000 MHz, pausing to adjust the R.F. signal level or to switch oscillators and antenna. The rate of sweep is in the order of 1.5×10^{-3} decades/s. The sensitive frequencies or frequencies of dominant interest may be discretely analyzed.

5.3.4. Test Setup

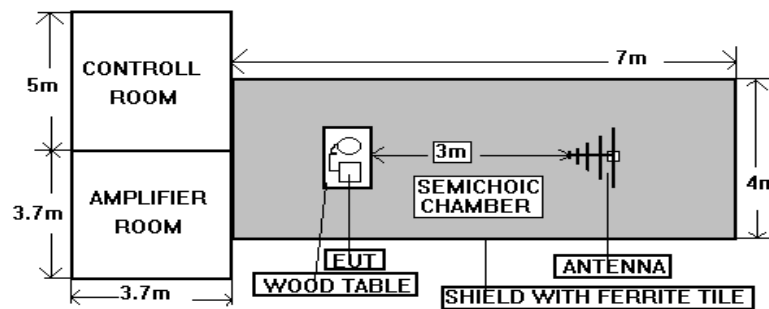

NOTE : The SPORTON 7m x 4m x 4m semi-anechoic chamber is compliance with the sixteen point's uniform field requirement as stated in IEC 61000-4-3 Section 6.2.

The procedure defined in this part requires the generation of electromagnetic fields within which the test sample is placed and its operation observed. To generate fields that are useful for simulation of actual (field) conditions may require significant antenna drive power and the resultant high field strength levels. To comply with local regulations and to prevent biological hazards to the testing personnel, it is recommended that these tests be carried out in a shielded enclosure or semi-anechoic chamber.

**5.3.5. Test Result**

Test mode	Mode 1		
Applicable Standard	EN 55035:2017+A11:2020 BS EN 55035:2017+A11:2020	Final Test Result	PASS
Frequency Range(swept)	80 to 1000 MHz		
Frequency Range(spot)	1800,2600,3500,5000 MHz ($\pm 1\%$)		
Electromagnetic field	3 V/m (unmodulated, r.m.s)		
Amplitude modulated	80% AM (1 kHz)		
Performance Criteria	A		

Frequency Range MHz	Test field strength V/m	Antenna Polarization	Azimuth Degree	Test Result (Criteria)	Remark
80~1000	3	V&H	0, 90, 180, 270	A	-
1800	3	V&H	0, 90, 180, 270	A	-
2600	3	V&H	0, 90, 180, 270	A	-
3500	3	V&H	0, 90, 180, 270	A	-
5000	3	V&H	0, 90, 180, 270	A	-



5.4. Power Frequency Magnetic Field (PFMF)

5.4.1. Test Specification

Reference Standard	IEC 61000-4-8
Frequency Range	50 or 60 Hz
Inductance Coil	1 m x 1 m

5.4.2. Test Levels

Level	Magnetic field strength A/m
1	1
2	3
3	10
4	30
5	100
x	Specified

Remark : " x " can be any level, above, below or in-between the other levels. This level can be given in the product specification.

5.4.3. Test Procedure

- a). The equipment is configured and connected to satisfy its functional requirements.
- b). The power supply, input and output circuits shall be connected to the sources of power supply, control and signal.
- c). The cables supplied or recommended by the equipment manufacturer shall be used. 1 meter of all cables used shall be exposed to the magnetic field.

5.4.4. Test Setup

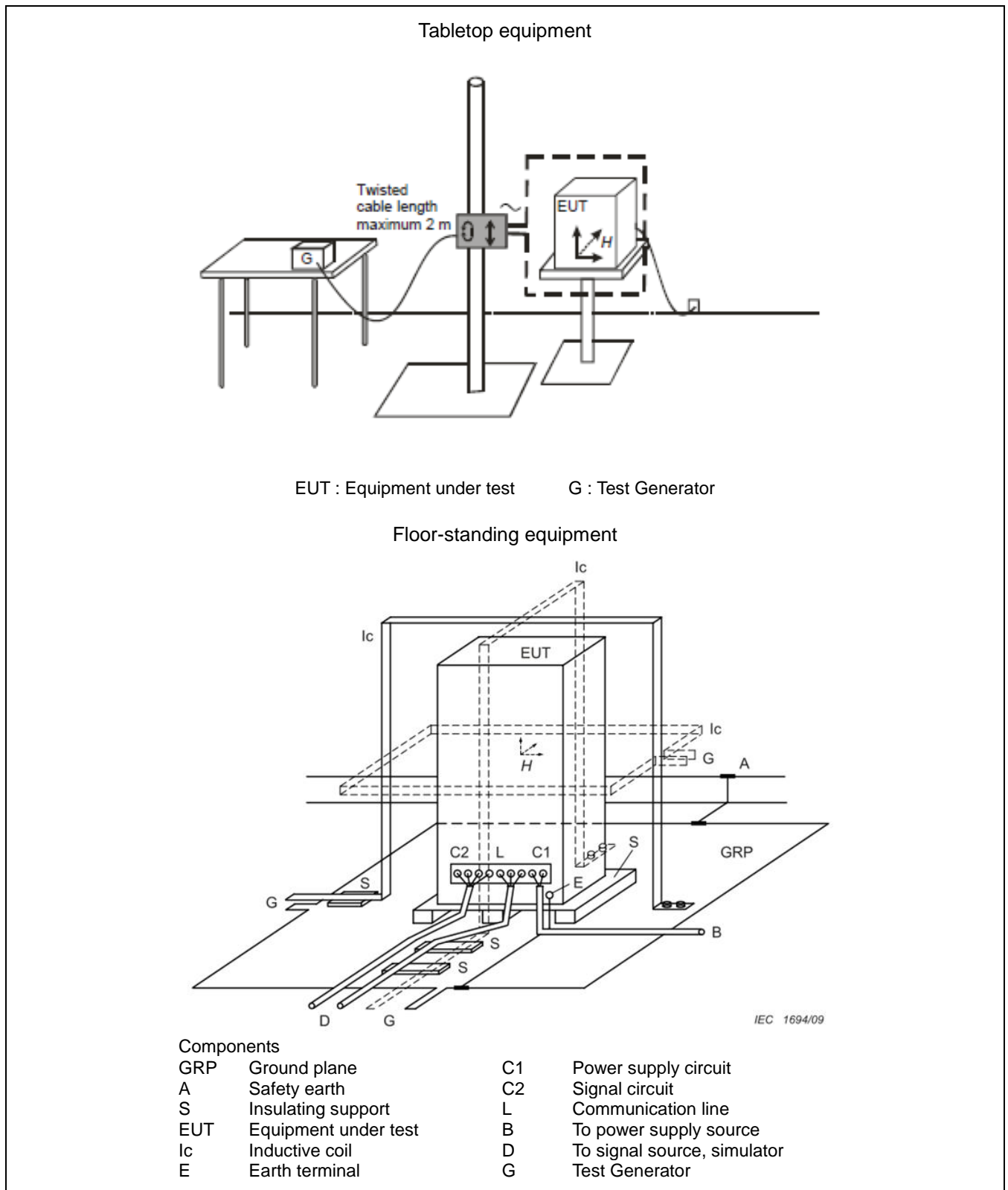

**5.4.5. Test Result**

Test mode	Mode 1		
Applicable Standard	EN 55035:2017+A11:2020 BS EN 55035:2017+A11:2020	Final Test Result	PASS
Power-frequency	50 Hz	Magnetic field	1 A/m (r.m.s.)
Performance Criteria	A		

Power Frequency Magnetic Field	Testing duration	Coil Orientation	Test Result (Criteria)	Remark
50Hz, 1A/m	1.0 Min	X-axis	A	-
50Hz, 1A/m	1.0 Min	Y-axis	A	-
50Hz, 1A/m	1.0 Min	Z-axis	A	-



6. Uncertainty of Test Site

ISO/IEC 17025 requires that an estimate of the measurement uncertainties associated with the emissions test results be included in the report. The measurement uncertainties given below are based on a 95% confidence level (based on a coverage factor (k=2)).

6.1. Emission Test Measurement Uncertainty

Test Items	Test Site No.	U_{LAB}
Conducted Emissions	CO01-NH	2.66 dB
Radiated Emissions below 1GHz	OS03-NH	5.07 dB
Radiated Emissions above 1GHz	03CH04-HY	3.53 dB



7. List of Measuring Equipment Used

Conducted Emission - Test Date: 10/Aug/2021

Instrument	Manufacturer/ Brand	Model No.	Serial No.	Characteristics	Calibration Date	Calibration Due Date	Remark
EMI Receiver	R&S	ESR	102318	9K Hz - 3.6 GHz	26/Jul/2021	25/Jul/2022	Conduction (CO01-NH)
LISN	SCHAFFNER	NNB41	06/10024	9kHz - 30MHz	28/Dec/2020	27/Dec/2021	Conduction (CO01-NH)
LISN (Support Unit)	MessTec	NNB-2/16Z	99079	9kHz - 30MHz	03/Feb/2021	02/Feb/2022	Conduction (CO01-NH)
Power Filter	CORCOM	MR12030	N/A	30A*2	NCR	NCR	Conduction (CO01-NH)
RF Cable-CON	Suhner Switzerland	RG223/U	CB004	9kHz - 30MHz	25/Dec/2020	24/Dec/2021	Conduction (CO01-NH)
software	Audix	E3	6.12160806	-	NCR	NCR	Conduction (CO01-NH)

NCR: No Calibration Required.

Radiated Emission below 1GHz - Test Date: 09/Aug/2021

Instrument	Manufacturer/ Brand	Model No.	Serial No.	Characteristics	Calibration Date	Calibration Due Date	Remark
Open Area Test Site	SPORTON	OATS-10	OS03-NH	30 MHz - 1 GHz 10m, 3m	20/Oct/2020	19/Oct/2021	Radiation (OS03-NH)
Amplifier	HP	8447D	2944A08292	0.1 MHz - 1.3 GHz	02/Jul/2021	01/Jul/2022	Radiation (OS03-NH)
Spectrum Analyzer	R&S	FSP7	838858/038	9 kHz - 7GHz	21/Jun/2021	20/Jun/2022	Radiation (OS03-NH)
Receiver	R&S	ESCS30	100357	9 kHz - 2.75 GHz	07/May/2021	06/May/2022	Radiation (OS03-NH)
Bilog Antenna With 5dB Attenuator	CHASE	CBL6112D	25234	30 MHz - 2 GHz	24/Apr/2021	23/Apr/2022	Radiation (OS03-NH)
Turn Table	EMCO	2080	9805-2065	0 - 360 degree	NCR	NCR	Radiation (OS03-NH)
Antenna Mast	EMCO	2075	9804-2151	1 m - 4 m	NCR	NCR	Radiation (OS03-NH)
RF Cable-R10m	HSCN	RG213U	2X11N	30 MHz - 1 GHz	13/Jul/2021	12/Jul/2022	Radiation (OS03-NH)
Software	Audix	E3	Ver.4	-	NCR	NCR	Radiation (OS03-NH)

NCR: No Calibration Required.

**Radiated Emission above 1GHz - Test Date: 13/Aug/2021**

Instrument	Manufacturer/ Brand	Model No.	Serial No.	Characteristics	Calibration Date	Calibration Due Date	Remark
EMI Test Receiver	R&S	ESU-26	100422	20Hz ~ 26.5GHz	03/Nov/2020	02/Nov/2021	Radiation (03CH04-HY)
Turn Table	Chaintek	3000	TT9664	0 ~ 360 degree	NCR	NCR	Radiation (03CH04-HY)
Antenna Mast	MF	MFA-515BSN	MFA-515BSN08 193	1 m ~ 4 m	NCR	NCR	Radiation (03CH04-HY)
3m Semi Anechoic Chamber (Site V.S.W.R)	RIKEN	SAC-3M	03CH04-HY	1 GHz ~ 18 GHz 3m	19/Feb/2021	18/Feb/2022	Radiation (03CH04-HY)
Microwave Preamplifier	Agilent	8449B	3008A02364	1GHz ~ 26.5GHz	01/Dec/2020	30/Nov/2021	Radiation (03CH04-HY)
Horn Antenna	SCHWARZBECK	BBHA9120 D	BBHA 9120 D-1130	1 GHz ~ 18 GHz	23/Oct/2020	22/Oct/2021	Radiation (03CH04-HY)
RF Cable-HIGH	HUBER+SUHNER	SUOFLEX 104	SN805197/4+M Y39497	1 GHz ~ 18 GHz	08/Mar/2021	07/Mar/2022	Radiation (03CH04-HY)
Software	Sporton	SENSE-EMI	V5.10.7	-	NCR	NCR	Radiation (03CH04-HY)

NCR: No Calibration Required.



EMS - Test Date: 21/Aug/2021

Instrument	Manufacturer/ Brand	Model No.	Serial No.	Characteristics	Calibration Date	Calibration Due Date	Remark
ESD Simulator	NoiseKen	ESS-B3011A	ESS1889000	Air: 0.5kV~30kV Contact: 0kV ~ 30kV	30/Jul/2021	29/Jul/2022	ESD
Magnetic field Immunity system	FCC (KEYTEK)	F-1000-4-8-G-1 25A,F-1000-4-8 /9/10-L-1AM	05004, 03004	30A//CONTINUOUS 100A/2Hrs 230A/30SEC	13/Oct/2020	12/Oct/2021	Magnetic
Harmonic/Flicker Test System	TESEQ	CCN1000-1	72471	4000VA 16A PEAK	31/Mar/2021	30/Mar/2022	Harmonic/Flicker
AC Power Source	TESEQ	NSG 1007-5	1510A00144	16A PEAK	31/Mar/2021	30/Mar/2022	Harmonic/Flicker
Software	AMETEK	CTS 4	Version4.21.0(2018)	-	NCR	NCR	Harmonic/Flicker
Signal Generator	ROHDE&SCHWARZ	SMB100A	108589	9kHz ~ 6GHz	07/Apr/2021	06/Apr/2022	RS
Power Amplifier	MILMEGA	80RF1000-300	1079234	80MHz ~ 1GHz, 300W	NCR	NCR	RS
Power Amplifier	MILMEGA	AS0860B-50/50	1079525	0.8 ~ 6GHz ,50W(0.8GHz~2GHz and 1.8GHz~6.0GHz)	NCR	NCR	RS
Amplifier controller	MILMEGA	AC-001	N/A	N/A	NCR	NCR	RS
Antenna	AR	ATL80M1G	348541	80MHz ~ 1GHz, 30W	NCR	NCR	RS
Antenna	SCHWARZBECK	STLP 9149	STLP9149 #490	700MHz ~ 10.5GHz	NCR	NCR	RS
EPM Series Power Meter	KEYSIGHT	N1914A	MY57070002	9 kHz to 110 GHz	07/Apr/2021	06/Apr/2022	RS
Avg Power Sensor	KEYSIGHT	E9304A	MY57020004	9kHz ~ 6GHz	07/Apr/2021	06/Apr/2022	RS
Avg Power Sensor	KEYSIGHT	E9304A	MY57030009	9kHz ~ 6GHz	07/Apr/2021	06/Apr/2022	RS
Fiber Optic modem	ETS-LINDGREN	HI-4413P	N/A	N/A	NCR	NCR	RS
Dual Directional Coupler	WERLATONE	C10117-10	112093	N/A	NCR	NCR	RS
Dual Directional Coupler	WERLATONE	C3908-10	112109	N/A	NCR	NCR	RS
RS immunity Test system	Sporton combination	Sporton RS	RS06HY	3V/m , 80MHz ~ 6GHz	17/Sep/2020	16/Sep/2021	RS
RF-Switch Network	TESEQ	RFB 2000	45818	N/A	NCR	NCR	RS
Probe	ETS-LINDGREN	HI-6105	00130664	0.1 MHz - 6GHz	24/Sep/2020	23/Sep/2021	RS
Software	Audix	i2	Version:5	-	NCR	NCR	RS

NCR: No Calibration Required.

Appendix A. Test Photos

1. Photographs of Conducted Emissions Test Configuration

Front View



Side View

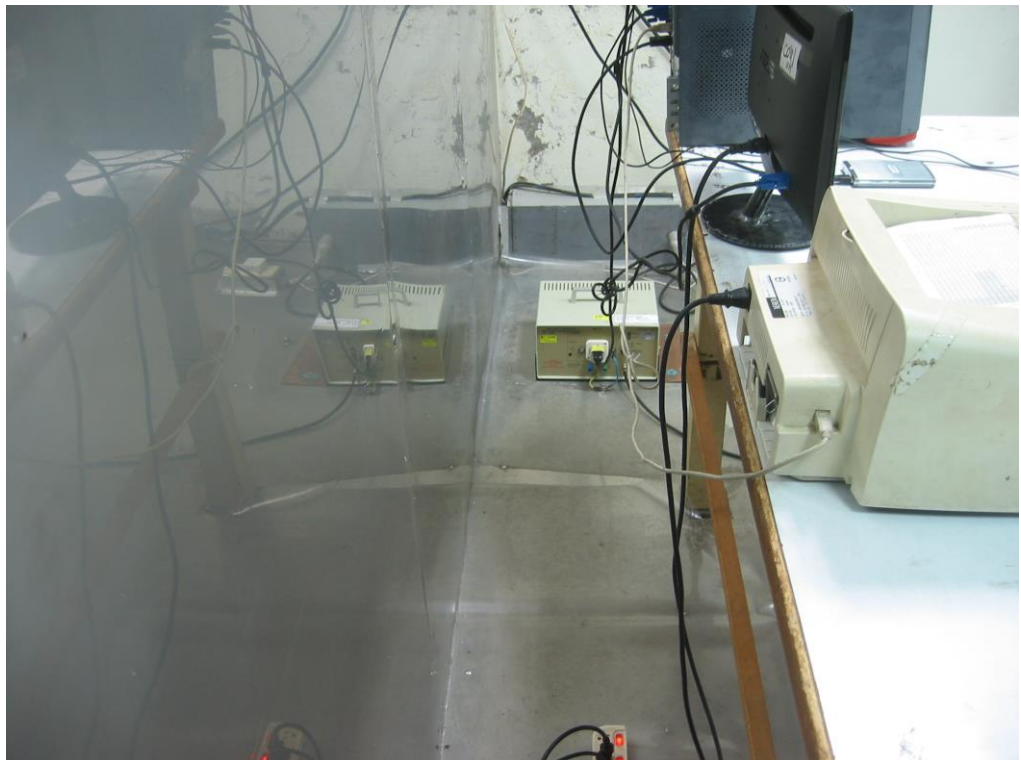

Under Table View

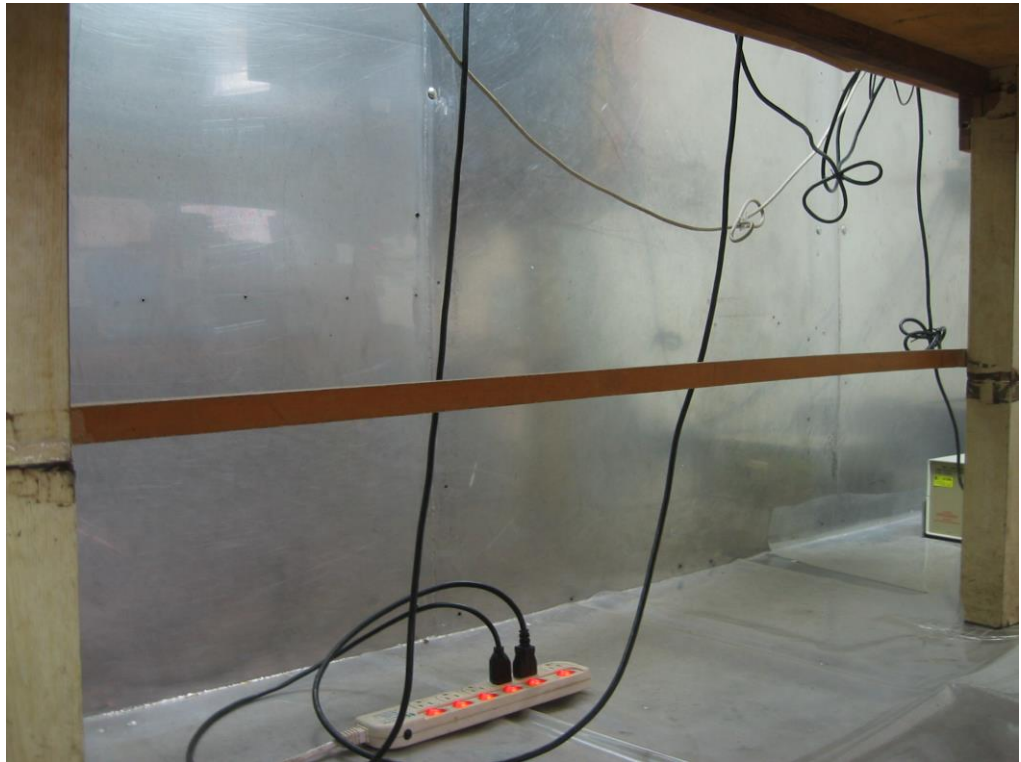

2. Photographs of Radiated Emissions Test Configuration

For radiated emissions below 1GHz

Front View

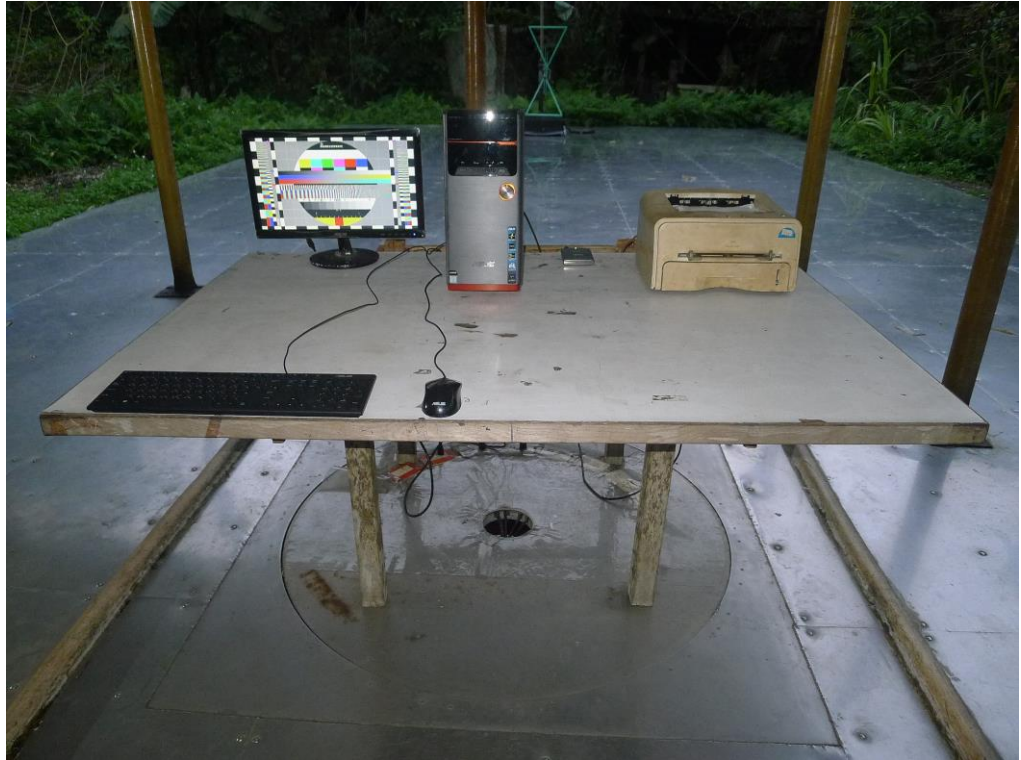

Rear View



For radiated emissions above 1GHz

Front View



Rear View

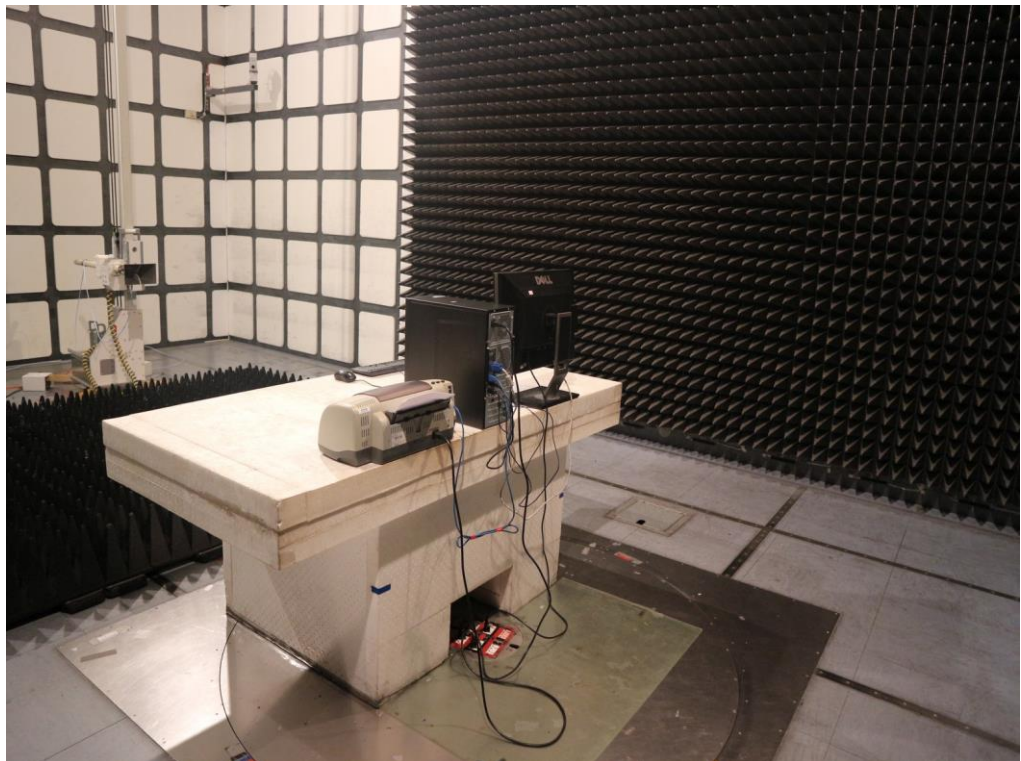

3. Photographs of Harmonic, Flicker Test Configuration

Front View



4. Photographs of ESD Immunity Test Configuration

Front View



Rear View



5. Photographs of RS Immunity Test Configuration

Front View

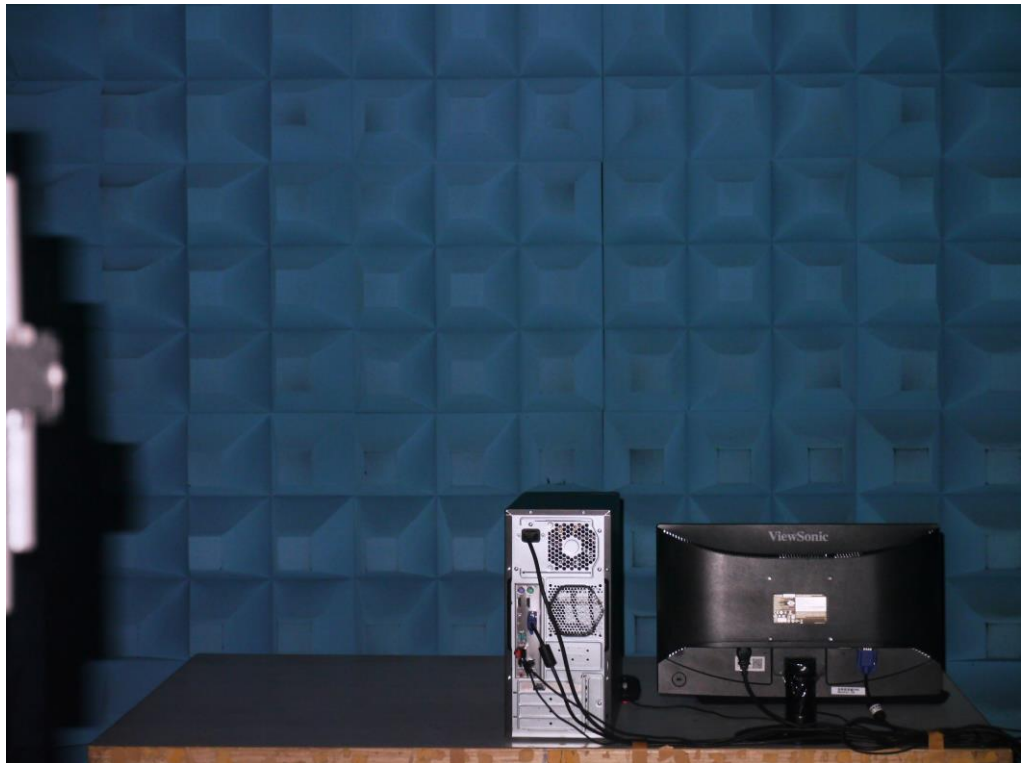

Rear View



6. Power Frequency Magnetic Field immunity Measurement (PFMF)

Front View

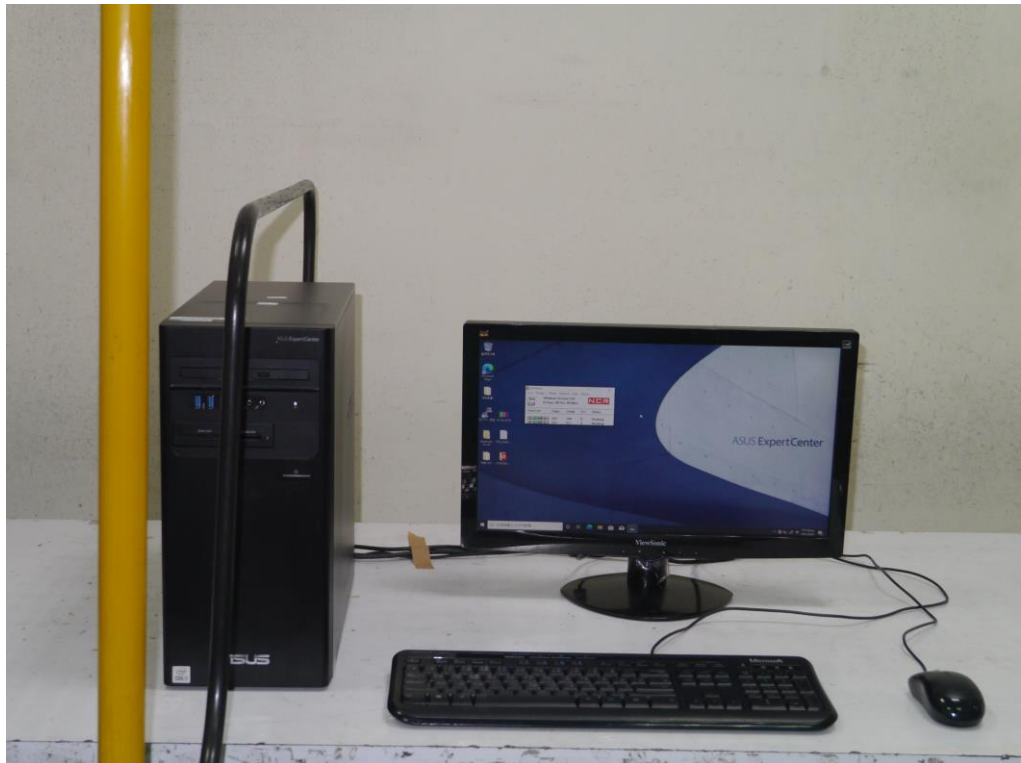

————THE END————